Uncontrolled flight into terrain, Cessna 335, N8345N, Hillsboro, Missouri, October 16, 2000

Micro-summary: This Cessna 335 crashed into terrain in turbulence, following instrumentation failure.

Event Date: 2000-10-16 at 1933 CDT

Investigative Body: National Transportation Safety Board (NTSB), USA

Investigative Body's Web Site: <http://www.nts.gov/>

Cautions:

1. Accident reports can be and sometimes are revised. Be sure to consult the investigative agency for the latest version before basing anything significant on content (e.g., thesis, research, etc).
 2. Readers are advised that each report is a glimpse of events at specific points in time. While broad themes permeate the causal events leading up to crashes, and we can learn from those, the specific regulatory and technological environments can and do change. ***Your company's flight operations manual is the final authority as to the safe operation of your aircraft!***
 3. Reports may or may not represent reality. Many many non-scientific factors go into an investigation, including the magnitude of the event, the experience of the investigator, the political climate, relationship with the regulatory authority, technological and recovery capabilities, etc. It is recommended that the reader review all reports analytically. Even a "bad" report can be a very useful launching point for learning.
 4. Contact us before reproducing or redistributing a report from this anthology. Individual countries have very differing views on copyright! We can advise you on the steps to follow.
-

Aircraft Accident Reports on DVD, Copyright © 2006 by Flight Simulation Systems, LLC
All rights reserved.
www.fss.aero



National Transportation Safety Board

Washington, D.C. 20594

Aircraft Accident Brief

Accident Number:	CHI01MA011
Operator/Flight Number:	N/A
Aircraft and Registration:	Cessna 335, N8354N
Location:	Hillsboro, Missouri
Date:	October 16, 2000

SUMMARY

On October 16, 2000, about 1933 central daylight time (CDT),¹ a Cessna 335, N8354N, crashed near Hillsboro, Missouri. The pilot and two passengers were killed, and the airplane was destroyed. The airplane was being operated under the provisions of 14 *Code of Federal Regulations* (CFR) Part 91 from the St. Louis Downtown Airport (CPS), Cahokia, Illinois, to County Memorial Airport (EIW), New Madrid, Missouri. Instrument meteorological conditions (IMC) prevailed for the flight, which departed CPS about 1915 on an instrument flight rules (IFR) flight plan.

HISTORY OF FLIGHT

During postaccident interviews, a St. Louis police officer who had provided security to one of the passengers on the accident airplane² stated that the pilot and two passengers arrived at CPS about 1140 on the day of the accident and then spent the day attending four campaign functions. Later that day, the pilot asked this security officer to take him back to the airport early so that he could prepare for the flight to EIW. The security officer stated that the pilot contacted the St. Louis Automated Flight Service Station (AFSS) to obtain a weather briefing during the drive back to CPS.³ The security officer also stated that the pilot then contacted the fixed-base operator (FBO) at CPS and asked to have the airplane's wing tanks topped off with fuel.

¹ Unless otherwise indicated, all times are CDT, based on a 24-hour clock.

² The passenger was the Governor of Missouri and was running for the U.S. Senate, and the purpose of the flight was to transport him to and from campaign functions.

³ For more information about the content of this briefing and the weather conditions that existed at and around the time of the accident, see the section titled, "Meteorological Information."

The security officer reported that after arriving at CPS about 1835, the pilot went into the FBO to check the weather on the computer and pay for the fuel. The security officer stated that when he asked the pilot if they were going to be able to make the flight to EIW, the pilot indicated that he did not anticipate that the weather would cause any problems with the flight and stated, "I've seen better days, but I've seen a lot worse." The security officer stated that the two passengers arrived at the airport about 1845 and then boarded the airplane. He stated that the pilot was seated in the left front seat but that he could not tell where the two passengers were seated.

According to Federal Aviation Administration (FAA) air traffic control (ATC) transcripts, at 1902:10, the pilot contacted the East St. Louis Air Traffic Control Tower (ATCT), Ground Control, and requested an IFR clearance to EIW. At 1902:17, the ground controller cleared N8354N as filed, instructed the pilot to climb to and maintain 2,100 feet and to expect 7,000 feet 10 minutes after takeoff, and issued a transponder code⁴ and departure frequency. At 1902:43, the ground controller cleared N8354N to taxi to runway 30L.⁵ At 1915:20, the pilot contacted the East St. Louis ATCT, Local Control, and stated that he was ready to depart from runway 30L. At 1915:24, the local controller issued N8354N a heading of 200° and cleared it for takeoff. At 1917:10, the local controller again instructed the pilot to turn left to a heading of 200° and to contact St. Louis Terminal Radar Approach (and departure) Control (TRACON). Eight seconds later, the pilot acknowledged the instruction.

At 1918:19, the pilot contacted St. Louis TRACON. At 1918:48, when the airplane was at approximately 2,200 feet, the St. Louis TRACON Low West (LW) controller informed the pilot of N8354N that he had radar contact with the airplane and instructed the pilot to turn left to a heading of 180° and climb to 2,600 feet. The pilot acknowledged these instructions. At 1920:00, the controller instructed the pilot to turn left to a heading of 150° and maintain 2,600 feet.⁶

At 1920:07, the pilot stated, "five four November we're having some problems uh with primary attitude indicator we'd like uh little bit...higher climb."⁷ The LW controller responded that he would be able to issue him a higher altitude "in about two miles." At 1920:51, the controller asked the pilot to state the airplane's altitude. The pilot replied, "we're at three thousand six hundred." The controller responded, "okay the uh assigned altitude was two thousand six hundred but climb and maintain four thousand." The pilot responded, "we got our hands full right now." At 1921:08, the controller stated, "uh roger

⁴ The airplane's transponder transmits aircraft information in response to interrogations by ATC secondary radar, including the aircraft's altitude, for processing and display.

⁵ According to the ATC transcript, the pilot asked the ground controller if he could depart from runway 12R instead of runway 30L. Although the controller responded that he could, she indicated that there would be a significant delay because of three inbound airplanes. The pilot replied that he would "go ahead and take three zero left" for takeoff.

⁶ ATC radar data indicate that at this time, the airplane was flying a course of about 250° at approximately 3,100 feet and climbing.

⁷ A review of the ATC recording revealed that when the pilot stated, "we're having some problems uh with primary attitude indicator," a great deal of background noise was recorded, which obscured the pilot's words.

you in some sort of difficulty.” The pilot responded, “we got a primary attitude indicator that’s not uh reading properly having to try and fly off of copilot [the right-side attitude indicator].” At 1921:20, the controller advised the pilot to try and fly the airplane level on any heading and told him that he would try to get him to as high an altitude as possible. The pilot responded, “appreciate it.”

At 1921:35, the LW controller told the pilot to fly “straight ahead” and stated that he would get him to visual flight rules (VFR) conditions. At 1921:52, the controller instructed the pilot to climb to and maintain 4,000 feet and to “let me know when you get on top [of the clouds].”⁸ The pilot acknowledged the instruction. At 1922:00, the controller asked another pilot, whose airplane was at 5,000 feet, if he was on top of the clouds, and the pilot responded that he was not.⁹ At 1922:33, the controller reported to N8354N, “I don’t have much hope for getting you on top uh people say it’s like about twelve five [12,500 feet].” At 1922:50, the pilot stated that he wanted to head toward Jefferson City Memorial Airport (JEF), Jefferson City, Missouri, because he understood that the weather conditions were better there. The controller then asked the pilot if his “instrument” was showing a heading of 150°, and the pilot responded “well the compass is showing due south one eight zero [180°].”¹⁰ At 1923:12, the controller instructed the pilot to turn to a heading of 120°, and the pilot acknowledged the instruction.¹¹

At 1923:39, the LW controller told the pilot to “climb and maintain seven thousand [feet] at pilot discretion.” The pilot acknowledged the instruction and added “we would like to go direct to jefferson city if possible.” The controller responded, “say jefferson city.”¹² The pilot responded, “that’s right jefferson city.” At 1923:55, the controller stated, “in that case turn right heading two seven zero.” The pilot then acknowledged the turn instruction and confirmed the assigned altitude.¹³

At 1925:12, the LW controller informed the pilot that “it appears you’re heading northwest but uh you’re basically in a good direction.” At 1928:36, the LW controller asked the pilot if he was still having “attitude problems.” The pilot replied, “the attitude problems are continuing.” ATC radar data indicate that at this time, the airplane’s altitude had reached 7,400 feet and that the airplane had entered a left turn to the southeast.¹⁴ The

⁸ ATC radar data indicate that when the LW controller issued this instruction, the airplane was at approximately 3,700 feet.

⁹ During postaccident interviews, the LW controller stated that he also asked other controllers at adjacent sectors if they had any reports of cloud tops and that the supervisor came over to his position to help him get weather reports.

¹⁰ ATC radar data show that the airplane had just turned south from a more southeasterly heading.

¹¹ In a written statement to the FAA, the LW controller indicated that he thought the pilot was asking for assistance in getting to his original destination (EIW) and that this was the reason he issued the 120° heading.

¹² During postaccident interviews, the LW controller stated that he was surprised when the pilot stated that he wanted to go to Jefferson City. He stated that he asked the pilot to confirm his request to go to Jefferson City because he thought the pilot wanted assistance continuing to EIW.

¹³ ATC radar data show that after this transmission, the airplane continued to climb and entered a right turn to the northwest.

¹⁴ The Safety Board could not determine why the airplane turned at this point.

data show that the airplane then descended slightly and that its altitude varied between 7,000 and 7,200 feet. At 1929:31, the pilot stated, “we’re gonna need some vectors somewhere where we can get down [to] VFR [conditions].”¹⁵ The LW controller stated that he would check around for other weather conditions and that, in the meantime, the pilot should “just go straight ahead...doesn’t make any difference what direction that is just go straight ahead.” At 1930:17, the controller told the pilot that the weather at Columbia Regional Airport, Columbia, Missouri, was 7,000 feet overcast with 7 miles visibility and light rain. The controller told the pilot that the further west he went the better the weather was going to be. He then asked the pilot if he wanted to head west. At 1930:35, the pilot responded, “that would be great.” This was the pilot’s last transmission.

At 1930:37, the LW controller told the pilot to “make a slow right turn as much as you can the standard rate...as much as you can to make this a stabilized affair.”¹⁶ ATC radar data show that after this instruction was issued, the airplane entered a right turn. ATC radar data further show that at 1931:17, the airplane had descended to approximately 6,500 feet. At 1931:22, the controller told the pilot to stop the turn and to fly straight ahead.¹⁷ At 1932:28, the controller unsuccessfully tried to contact N8354N. At 1932:34, the controller transmitted, “november three five uh five four november radar contact lost.”¹⁸

The accident occurred at night in dark lighting conditions. The location of the accident site was 38° 18.653' north latitude, 90° 30.125' west longitude at an elevation of about 826 feet mean sea level.

PERSONNEL INFORMATION

Pilot

The pilot, age 44, held a commercial pilot certificate with airplane multiengine land and instrument airplane ratings and a private pilot certificate with airplane single-engine and multiengine land¹⁹ and single-engine sea ratings. The pilot’s most

¹⁵ During postaccident interviews, the controller stated that he became concerned when the pilot requested vectors to VFR conditions and that, in his opinion, this was the first time that the pilot conveyed a sense of urgency regarding his situation.

¹⁶ According to the “Pilot/Controller Glossary,” a standard rate turn is a turn of 3° of heading change per second.

¹⁷ ATC radar show that after this instruction, the airplane climbed for the next several seconds, reaching its maximum altitude of 7,700 feet, and then descended rapidly.

¹⁸ The last radar contact with the airplane was at 1931:57, at which time, the airplane was at an altitude of 2,700 feet.

¹⁹ On January 14, 1993, the pilot was denied a private pilot multiengine land rating because he followed improper single-engine go-around procedures. On January 16, 1993, the pilot passed a subsequent checkride, and he received a private pilot multiengine land rating.

recent FAA second-class airman medical certificate was issued on January 21, 2000, and contained the limitation that he wear corrective lenses.

The last entry in the pilot's logbooks was dated April 27, 2000. Investigators used the pilot's logbooks, campaign flight logs, and flight logs from other airplanes the pilot had flown²⁰ to estimate the pilot's total flight experience. The pilot's estimated total flight time at the time of the accident was about 1,829.7 hours, including about 735 hours of multiengine flight time, of which 513 hours were in a Cessna 335. The pilot's estimated total night flight time was about 460.5 hours, of which 157.4 hours were in a Cessna 335.

The pilot's estimated total actual instrument flight time was about 87.6 hours, of which 22.4 hours were in a Cessna 335.²¹ His estimated total simulated instrument flight time was about 65.2 hours, of which 1 hour was in a Cessna 335. Records indicate that the pilot's most recent instrument proficiency checkride was on September 21, 1999. Flights recorded in the pilot's logbook that contained the remark "partial panel flight" totaled to about 12.3 hours,²² none of which were in a Cessna 335.

The pilot's estimated flight time in the 90 days before the accident flight was about 93.6 hours, of which 81.3 hours were in a Cessna 335. The pilot's estimated flight time in the 30 days before the accident flight was about 38 hours, of which 32.4 hours were in a Cessna 335.

According to the pilot's personal physician, the pilot was in "excellent health" during the 12 months before the accident. He reported that the pilot had no acute illnesses; did not take any medications; and did not use alcohol, tobacco, or caffeine. Family and friends reported that the pilot exercised on a regular basis, preferring to run or walk in the mornings. Friends also reported that he would not have flown if he were tired. Further, they stated that he had been known to cancel trips when the weather conditions were unfavorable.

Pilot's Training

A review of training records shows that the pilot received an insurance "checkout" from a flight instructor in the accident airplane between November 21 and December 6, 1997. The checkout consisted of 15 hours of flight time, during which the pilot was

²⁰ The pilot had been co-owner of a Piper PA-28-181 Archer since February 1, 1989, and had also flown a Beechcraft B33 Debonair registered to one of the passengers.

²¹ The last entry in the pilot's logbook that shows that he flew in IMC was on March 15, 2000, at which time he logged 1.5 hours of instrument flight time. The Safety Board could not determine how much of the flight time that the pilot had accumulated since his last logbook entry on April 27, 2000, was in IMC nor could the Board determine if the pilot had met the flight experience required by CFR Section 61.57 to act as pilot-in-command (PIC) in IMC.

²² Partial panel flight refers to flight training in which it is simulated that some of an airplane's instruments (for example, the attitude indicator) have failed by either covering them up or removing power from them. All of the flight time documented as partial panel flight time by the pilot was simulated during training flights with an instructor. The Safety Board could not determine how much of each flight's total time was devoted to partial panel instruction.

exposed to systems training and IMC, normal, and emergency procedures. The pilot logged 2.5 hours of this flight time as instrument training and 7.5 hours as night flight time.

From May 15 through 17, 1998, the pilot attended and completed a Systems and Operational Procedures Training Seminar held by Twin Cessna Flyer, Defiance, Ohio. According to the course materials, the course's primary purpose was to "help the pilot/owner of twin Cessna aircraft prevent emergencies and accidents through increased knowledge of aircraft systems and operational procedures." The course included 3 days of classroom and lab instruction. The instruction covered the following information: systems—knowledge, operation, and maintenance; normal and emergency procedures; decision-making and judgment; and proficiency flying. A portion of the course manual titled, "Normal and Emergency Operating Procedures," covered the twin Cessna's vacuum system.²³ The course manual also contained a Twin Cessna Checklist, which included performing a vacuum system check as part of the engine start and shutdown procedures. Further, a copy of the Pilot Operating Handbook Supplement that outlined the engine start and shutdown procedures, which includes the performance of a vacuum system check, was distributed to and discussed with the attendees as they were reviewing the vacuum system.

Pilot's 72-Hour History

Coworkers, friends, and the pilot's sister provided information to Safety Board investigators about the pilot's activities during the 72 hours before the accident. On October 13, 2000, the pilot was reported to have arrived at his office in Rolla, Missouri, sometime between 1430 and 1600 and to have departed about 1800. From about 2000 to 2200, the pilot was reportedly at his home visiting with the caretakers of his farm. The pilot reportedly drove the caretakers and their family back to their house and arrived back home between 2230 and 2300.

On October 14th, the pilot was seen at his home between 0930 and 1000, where he was getting ready for a trip. According to the pilot's sister, he flew N8354N from Rolla to Columbia, Missouri, where he attended a football game. According to a campaign schedule, the pilot was scheduled to depart Columbia at 1405 and arrive in Creve Coeur, Missouri, at 1450. According to the pilot's sister, after arriving at Creve Coeur, the pilot departed for Cuba, Missouri, and then continued on to Rolla.

On October 15th, the pilot attended church in Rolla. About 1208, the pilot sent an e-mail to a friend stating that he had flown for the campaign almost every day recently, that he had slept soundly at home the night before, that he was over a cold, that he had run the day before after not having run in over a week, that he was heading for Kansas City that afternoon, and that he was returning to Jefferson City that night. The caretaker's wife reported that the pilot called her from his office between 1000 and 1300. The pilot's sister reported the he departed Rolla about 1400 to pick up their parents in St. Louis to fly them

²³ A review of the course manual did not reveal to what extent vacuum pump failures were discussed during the training.

to Kansas City. According to a campaign schedule, the pilot was scheduled to depart Creve Coeur at 1445 and arrive in Kansas City at 1615. The pilot was then scheduled to depart Kansas City at 2045 and arrive in Jefferson City at 2135, where he was expected to spend the night.

On October 16th, the pilot was scheduled to depart JEF at 1025 and arrive at CPS at 1110. According to a security officer, the airplane actually arrived at CPS about 1140. Both the pilot and passengers proceeded to scheduled campaign events. That afternoon the pilot called his office and stated that he was running behind schedule and that he would not be in the office that day as he had previously planned. The pilot's sister reported that the pilot visited the campaign office in the afternoon where he checked the weather on a computer before leaving for the next campaign event about 1645. About 1815, the pilot asked one of the security officers to take him back to the airport early so that he could prepare for the flight to EIW.

Pilot-rated Passenger

One of the accident airplane's passengers was a licensed pilot. On August 25, 1997, he obtained a private pilot certificate with an airplane single-engine land rating. On May 16, 1999, he obtained an instrument airplane rating. He held a third-class medical certificate with the limitation that he must wear lenses for distant vision and possess glasses for near vision. He owned and flew a Beechcraft B33 Debonair. Members of the security detail and other pilots who had traveled previously with this passenger stated that although he was a licensed pilot, he normally sat in the back of the airplane when there were other passengers on board or when he needed to prepare for his next campaign event.

Air Traffic Controller

The St. Louis TRACON LW controller, age 54, was hired by the FAA in 1968. Before being hired by the FAA, he was an air traffic controller in the U.S. Air Force for 3 1/2 years. The controller's first assignment with the FAA was at the Chicago O'Hare International Airport (ORD), Chicago, Illinois, ATCT. He worked at the ORD ATCT from 1968 until 1970 or 1971.²⁴ The controller then went to work at the Rockford, Illinois, ATCT until 1977. He then worked at the ORD TRACON until 1980, at which time, he left to work at the St. Louis TRACON. The controller held an airline transport pilot certificate with an airplane multiengine land rating, a commercial glider certificate, and a certified flight instructor glider certificate. He held type ratings for Falcon-20, -50, and -900 series airplanes. He reported that his total flight time was approximately 6,800 hours. On the day of the accident, he was assigned to work from 1550 to 2355; however, he arrived at the facility about 1520. The controller had been working at the LW position for about 45 minutes before handling the accident airplane.

The controller stated that after starting his shift, during his briefing, he was informed that level 1 through level 3 weather existed in the area.²⁵ He reported that he

²⁴ The controller could not remember the exact date that he left the ORD ATCT.

selected level 2 and level 3 on his computer display and that it indicated that only level 2 weather existed in the area. The controller reported that air traffic in his area of responsibility was “typical and routine.”

AIRPLANE INFORMATION

General

The accident airplane, N8354N, a Cessna 335,²⁶ serial number (S/N) 335-0063, was manufactured by the Cessna Aircraft Company in 1980. Airplane records show that the pilot’s business (a law firm) purchased the airplane on November 27, 1997. The airplane had six previous owners. The last entry in the Airframe Maintenance Record (logbook), dated September 28, 2000, shows that, at that time, the airplane had 2,299.4 total hours of operation.

The accident airplane was equipped with two Continental TSIO-520-EB8 engines (left engine S/N 271477-R and right engine S/N 271478-R), which the Rebuilt Engine Logs indicate were zero-time, factory-rebuilt engines that were installed on the airplane on August 27, 1997. The last entry in the Rebuilt Engine Logs, also dated September 28, 2000, shows that, at that time, the left engine had operated about 489.7 hours and the right engine had operated about 475.5 hours since remanufacture. The accident airplane was equipped with a 400B Nav-o-matic Autopilot system. Maintenance records show that a WX-11 Stormscope system was installed in the airplane on December 31, 1991, and that on November 19, 1998, it was repaired and reinstalled.

According to airplane maintenance records, the last transponder, altimeter, static system check was performed on May 22, 2000, and the last annual inspection was accomplished on August 21, 2000, at a total airframe time of 2,257 hours.

Assuming that about 30 pounds of baggage were on board²⁷ and that the airplane’s main fuel tanks were full, the airplane did not exceed its operational weight and balance limitations.

²⁵ Level 1 weather conditions include very light precipitation measuring between about 0.01 and 0.04 inch per hour with a reflectivity of between 15 and 29 decibels. Level 2 weather conditions include light to moderate precipitation measuring between about 0.09 and .21 inch per hour with a reflectivity of between 30 and 39 decibels. Level 3 weather conditions include strong precipitation measuring about .48 inch per hour with a reflectivity of between 40 and 44 decibels. Reflectivity is the measure of the efficiency of a target in intercepting and returning radio energy.

²⁶ The Cessna 335 is a twin-engine, low-wing airplane with retractable landing gear.

²⁷ Witnesses on the ground indicated that the passengers were carrying what appeared to be brief cases. On the basis of this information and the fact that the passengers were not expected to spend the night in New Madrid and, therefore, would not have needed overnight luggage, the Safety Board estimated that the amount of baggage on board the airplane was about 30 pounds.

Cessna 335 Vacuum System

According to the Cessna 335 Maintenance Manual, the Cessna 335 vacuum system consists of a dry vacuum pump²⁸ on each engine, two pressure relief valves, a manifold air filter,²⁹ vacuum-operated instruments, and necessary plumbing. The pump outlets (pressure sides) are routed to deicing equipment and primarily exhausted into the engine nacelle. Vacuum lines are routed from the vacuum pumps through the nacelles to the relief valves mounted in each wing root area. From the relief valves, additional vacuum lines are routed through the inboard portion of the wing then through the cabin to the vacuum manifold (located on the left side of the forward cabin bulkhead), which has check valves to prevent reverse flow in the event that either vacuum pump fails.

Hoses are routed from the vacuum manifold to the vacuum system instruments, which include a heading indicator, an attitude indicator, and a vacuum gage for the standard installation. The heading indicator is an air-driven, gyro-controlled directional indicator designed to provide stable heading references. The attitude indicator has a fixed-airplane silhouette and a pitch-and-roll display that moves behind the airplane.³⁰ The movement of the display is guided by the attitude of the actual airplane in relation to a single air-driven gyroscope. The vacuum gage indicates the amount of vacuum in the system and the operational status of each pump and has red indicator buttons that will extend in the event of a pump failure.

The Cessna 335 Pilot's Information Manual states the following about the vacuum system:

Each vacuum pump pulls a vacuum on the common manifold; exhausting the air overboard. The maximum amount of vacuum pulled on the manifold by each vacuum pump is controlled to a preset level by each pressure relief valve. Should either of the pumps fail, a check valve is provided in each end of the manifold to isolate the inoperative vacuum pump from the system...The vacuum pressure being applied to the gyros is constantly presented on the suction gage. This gage also provides failure indicators for the left and right vacuum pumps. These indicators are small red buttons located in the lower portion of the suction gage which are spring-loaded to the extended (failed) position. When normal vacuum is applied in the manifold, the failure buttons are pulled flush with the gage face. Should insufficient vacuum occur on either side, the respective red button will extend. No corrective action is required by the pilot, as the system will automatically isolate the failed vacuum source, allowing normal operation on the remaining operative vacuum pump.

²⁸ The dry vacuum pumps, which require no lubrication, are located on the aft left accessory mount pad on each engine. For a diagram of a Cessna 335 vacuum pump, see the section titled, "Component Examination."

²⁹ The manifold air filter is mounted behind the cockpit instrument panel.

³⁰ For a photograph of an exemplar attitude indicator and its components, see the section titled, "Component Examination."

According to Cessna delivery documents, the airplane was manufactured and delivered to the first owner with complete left-side flight instrumentation.³¹ The vacuum-driven instruments installed on the left side of the instrument panel consisted of a horizontal situation indicator that incorporated a heading indicator (S/N W7153B) and an attitude indicator (S/N A4118K). The pitot-static instruments installed on the left side of the instrument panel included an encoding altimeter, an airspeed indicator, and a vertical speed indicator. The only electrically driven navigation instrument on the left panel was the turn and bank indicator.

Cessna's delivery documents show that the only flight instrument installed on the right side of the instrument panel at the time of manufacture was a pitot-static altimeter. Before the pilot's business purchased the airplane, a second attitude indicator and its respective vacuum system plumbing and fittings were installed on the right side of the instrument panel.³²

Accident Airplane Maintenance History

Sigma-Tek records show that the attitude indicator/flight director³³ installed in the airplane at the time of the accident was an overhauled unit that it had shipped to the most recent previous owner in 1996.³⁴ According to airplane maintenance records, in December 1999, this instrument was removed to clean the pitch slip rings and was then reinstalled in the airplane.

According to airplane maintenance records, the factory-new vacuum pumps were installed on the left and right engines on March 28 and April 10, 1997, respectively.³⁵ According to an airframe and powerplants mechanic who worked on the airplane, the pilot contacted him on September 25, 2000, and stated that he thought his left engine vacuum pump had failed. The mechanic stated that he discussed the issue with the pilot and requested that he bring the airplane in for repairs. The mechanic stated that the pilot brought the airplane in on September 27th and that on September 28th, he removed and

³¹ According to 14 CFR Section 91.205, the following instruments are required to be installed on an airplane for instrument flight: an airspeed indicator; an altimeter; a magnetic direction indicator (compass); a gyroscopic rate of turn indicator; a slip-skid indicator; a clock that displays hours, minutes, and seconds; an attitude indicator; and a heading indicator.

³² A review of maintenance records and work orders did not reveal when the right-side attitude indicator was installed; however, the mechanic who performed the prebuy inspection of the airplane for the pilot's business reported that it was already installed when the business purchased the airplane. During postaccident interviews, the most recent previous owner of N8354N stated that he only remembered having flight instruments on the left side of the instrument panel. However, according to the manufacturer of the instrument, Sigma-Tek, the S/N on the right-side attitude indicator matched the S/N of an attitude indicator that it had shipped to this owner in 1996.

³³ Airplane maintenance records indicate that in 1985, the left-side attitude indicator was replaced with an attitude indicator/flight director manufactured by Sigma-Tek.

³⁴ A fragment of an instrument case recovered from the accident site had a Sigma-Tek sticker dated April 10, 1996, marking it as an exchange part.

³⁵ Maintenance records also indicate that the vacuum relief valve filter elements were replaced in October 1999.

replaced the left engine vacuum pump.³⁶ The mechanic reported that he performed a postmaintenance operational check on both vacuum pumps and that the pumps operated normally.

The mechanic also reported that on September 29, 2000, he removed the right side attitude indicator for overhaul³⁷ and installed a placard on the instrument panel that stated, “CO-PILOTS HORIZON GYRO REMOVED FOR O/H 9/29/00.” The mechanic stated that the pilot had called him on October 9th or 10th to check on the status of the right-side attitude indicator (referred to here as the “co-pilot’s horizon gyro”). According to the mechanic, during this conversation, the pilot told him that since the removal of the part, the vacuum gage had been reading lower than “what he was accustomed to seeing.” The mechanic stated that he explained to the pilot that “the removed instrument is a restriction on the vacuum system and since it had been removed, that was the most likely reason for the lower reading.”

The mechanic stated that he reinstalled the right-side attitude indicator on October 11th and checked its and the vacuum system’s operation. He reported that he was satisfied with the operation of both and that he removed the placard for the attitude indicator. The mechanic reported that he informed the pilot of the work that had been done and told him to monitor the vacuum gage reading on his next flight to see if the lower than usual reading he had reported earlier had been corrected by reinstalling the overhauled attitude indicator. The mechanic stated that the pilot did not inform him if the lower than usual vacuum gage reading had been corrected by the reinstallation of the overhauled attitude indicator.

The mechanic also reported that on September 29, 2000, he removed the electric pitch trim servo for overhaul and installed a placard on the instrument panel that stated, “PITCH TRIM SERVO REMOVED FOR O/H 9/29/00.” The mechanic reported that the pilot questioned whether or not he could use the autopilot with the servo removed. The mechanic stated that to answer the pilot he called an autopilot repair station and was informed that “the system could be used but it would put more load on the pitch servo itself.”³⁸ The mechanic reported that on October 11th, he reinstalled the electric pitch trim servo and determined that it was still inoperative. He reported that he contacted the overhaul facility and was instructed to return the unit for further repairs. The mechanic reported that he again installed a placard on the instrument panel stating, “PITCH TRIM SERVO REMOVED FOR REPAIR 10/11/00.”

³⁶ The manifold air filter was recovered in the wreckage. The recovered air filter had an ink-stamped manufacturing date of May 2000, and “9/29/00” was hand-written on the cover, which indicates the date that it was installed on the airplane.

³⁷ The right-side attitude indicator was shipped to Mid-Continent Instrument Company for overhaul. A Work Order and Inspection Sheet for the attitude indicator noted, “Filter contaminated Rotor Noisy. All bearings sluggish. Threads on vacuum fitting crossfeed causing vac[uum] port to get chewed up.”

³⁸ With the electric pitch trim motor removed, elevator pressure could be applied by the electrically driven autopilot pitch servo if the autopilot were engaged and the pilot was not continuously retrimming the airplane manually.

Cessna Service Bulletins

Service Bulletin MEB99-19

On October 4, 1999, the Cessna Aircraft Company issued Service Bulletin (SB) MEB99-19 to do the following:

Add vacuum system check procedures for the Pilots Operating Handbook, Owners Manual and Aircraft Flight Manual. These procedures are being added to the existing Engine Start and Shutdown procedures to detect for a possible defective vacuum system check valve or failed vacuum pump prior to flight. Non-compliance with this Service Bulletin may allow a defective vacuum system check valve or failed vacuum pump to go unnoticed which could result in a pilot using instruments for flight that are not providing proper information due to a malfunctioning and/or failed vacuum system....the revisions shall be reviewed and incorporated as soon as possible, but no later than the next 100 hours of operation or 4 months, whichever occurs first.

In part, SB MEB99-19 describes the engine start and shutdown procedures as follows:

STARTING ENGINES

AFTER FIRST ENGINE IS STARTED:

With throttles set at 1000 RPM or higher:

1. Suction Gage – CHECK (reading in green arc)
2. Check that the red vacuum failure button in the suction gage for that engine is flush with the gage face, prior to starting the opposite engine.
 - a. If failure button remains extended (not flush with gage face), a vacuum source failure has occurred.
 - b. If both failure buttons are flush with face of gage, a vacuum system check valve is defective.

AFTER SECOND ENGINE IS STARTED:

With throttles set at 1000 RPM or higher:

1. Suction Gage – CHECK (reading in green arc)
2. Check that the red vacuum failure button in the suction gage for the engine is flush with the gage face.
 - a. If failure button remains extended (not flush with gage face), a vacuum source failure has occurred.

SHUTDOWN

ENGINES:

1. Shut down engine that was started first.
 - a. The red vacuum failure button for that engine in the suction gage should extend.
 - b. If the failure button for the shutdown engine remains flush with the face of the gage, a vacuum system check valve is defective.
2. With throttle set at 1000 RPM or lower on the running engine, check that the red vacuum failure button in the suction gage for that engine is flush with the gage face.
 - a. If the red vacuum failure button for the running engine extended when the first engine was shutdown, a vacuum system check valve and/or pump is defective.

Cessna Aircraft Company records indicate that SB MEB99-19 was mailed to the registered owner of N8354N on October 4, 1999. During postaccident interviews, pilots who had flown with the accident pilot reported that he used these procedures routinely. A portion of the procedures outlined in the SB was found in the wreckage.

Service Bulletin MEB00-5

On October 2, 2000, the Cessna Aircraft Company issued SB MEB00-5 to do the following:

Provide inspection and replacement intervals for the vacuum system manifold check valve. Non-compliance with this Service Bulletin may allow a defective vacuum manifold check valve to go unnoticed which could result in: a pilot using instruments for flight that are not providing proper information, and/or a de-ice system not properly inflating the boots due to a malfunctioning and/or failed manifold check valve....shall be accomplished within the next 100 hours of operation or 12 months, whichever occurs first. Refer to Airborne Product Reference Memo No. 39 (or latest revision) for possible subsequent inspections and valve replacement intervals.

Airborne Product Reference Memo No. 39 applied to N8354N because it had a 1H5 Series vacuum check valve manifold installed in it. The memo states the following:

The...components supplied by Airborne for use in aircraft pneumatic systems are manufactured with elastomeric components that deteriorate with age. As these components age, it is increasingly important to periodically assure their proper operation, thus avoiding unscheduled system problems and aircraft downtime...It is recommended that beginning five years from date of manufacture, the serviceability of these components

be verified every twelve months in accordance with the procedure provided on the applicable Airborne Technical Service Instruction. It is further recommended that these pneumatic system check valve manifolds and check valves be replaced ten years from date of manufacture...The 1H5 series check valve manifold provides a means of coupling dual vacuum sources. More importantly, the 1H5 check manifold provides a means of isolating these dual vacuum sources in the event that one of the sources is not in operation....The 'flapper-type' check valves are spring loaded in the closed position. As airflow is pulled through the manifold, the check valves open allowing airflow through the instruments. If airflow through a check valve is stopped (i.e., vacuum source taken out of operation), the check valve will close in order to allow the pneumatic system to properly function utilizing the lone operating vacuum source.

Cessna Aircraft Company records indicate that SB MEB00-5 was mailed to the registered owner of N8354N on October 2, 2000. It is unknown if the pilot/owner of N8354N received this SB. The mechanics that routinely performed maintenance on N8354N stated that they did not have any discussions with the pilot regarding SB MEB00-5.

METEOROLOGICAL INFORMATION

About 1602 on the day of the accident, the pilot contacted the St. Louis AFSS for a weather briefing. According to a recording of the conversation, the pilot requested the weather for the first leg of the planned flight (from CPS to EIW) with a scheduled departure time of 1730 and a planned cruising altitude of between 5,000 and 9,000 feet. He also requested weather for the second leg of the proposed flight (from EIW to JEF) with a scheduled departure time of 2030. The briefer indicated that there was a low-pressure system and a stationary front over southern Missouri. The briefer also indicated that there was an extensive area of IFR conditions north of the front, that an AIRMET (airmen's meteorological information)³⁹ was current for the area, and that a large band of rain showers extended over the area. The briefing included the current conditions for airports along the route of flight, the forecast for southern Missouri, winds aloft data, and available pilot reports. The briefer reported that the cloud tops were expected to be at approximately 25,000 feet. After receiving this information, the pilot stated that he would call back for an update and to file his flight plans.

About 1811, the pilot contacted the St. Louis AFSS for an updated weather briefing and to file his IFR flight plans. The pilot told the briefer that the first leg of the flight would take 1 hour and that there were 4.5 hours of fuel and three people on board. The briefer informed the pilot that the current weather conditions at CPS were wind 010° at 9 knots; visibility 2 miles with rain and mist; broken cloud ceiling at 600 and 1,000 feet,

³⁹ AIRMET Zulu update 3 was issued at 1431 and was valid until 2100 on the day of the accident. The AIRMET called for moderate rime to mixed icing in clouds and in precipitation between 12,000 and 22,000 feet. This AIRMET covered portions of Illinois, Indiana, Missouri, and Kentucky.

2,500 feet overcast; temperature 15° Celsius (C); and dew point 14° C. The briefer reported that an area of low pressure was moving into New Madrid along with a stationary front. The briefer further reported that there was a chance of moderate rime or mixed icing above 12,500 feet and that there were several thunderstorms along and around the pilot's intended route of flight. The briefer then informed the pilot that the St. Louis winds aloft for 3,000 feet were 050° at 10 knots and that the winds at 6,000 feet were light and variable. The briefer informed the pilot that near New Madrid, the winds aloft were light and variable at 3,000 feet and 200° at 12 knots for 6,000 feet.

The briefer asked the pilot if he wanted to file an altitude for the flight plan, and the pilot responded, "7,000 feet." The pilot then changed his previous estimated departure time from 1830 to 1845 and stated that he wanted to fly directly to EIW. The pilot then filed a flight plan for the flight from EIW to JEF. The briefer then informed the pilot that he would be flying too low for ice but that it was "naturally gonna be a little bumpy in that semi cumulus type form stuff ah so ah you know maybe bases and tops if you happen to find em." The weather briefing ended about 1827.

A National Weather Service National Center for Environmental Prediction regional surface analysis chart showed that the main weather features at the surface within the hour of the accident included a low-pressure system over southern Missouri, a cold front to the southwest of the low-pressure system, a stationary front to the east of the low-pressure system, and a trough⁴⁰ of low pressure to the south of the low pressure system, extending southward into Arkansas. A second weather system, identified as a trough of low pressure, was approaching the area to the northwest. A high-pressure system was identified over Wisconsin, with a ridge of high-pressure extending over Iowa, northern Missouri, and eastern Kansas.

The CPS (located 28 miles northeast of the accident site) special surface weather observation for 1920 was as follows:

wind from 020 degrees at 12 knots gusting to 16 knots, visibility 2 miles in light rain and mist, ceiling broken at 600 feet, broken at 1,200 feet, and overcast at 3,200 feet, temperature 15 degrees C (59 degrees [Fahrenheit] F), dew point 14 degrees C (57 degrees F), altimeter 30.06 inches [mercury] Hg. Remarks; automated observation, precipitation since 1853 was reported at 0.04 of an inch.

The CPS special surface weather observation for 1953 was as follows:

wind from 030 degrees at 11 knots, visibility 2 1/2 miles in moderate rain and mist, ceiling broken at 800 feet, overcast at 1,200 feet, temperature 15 degrees C (59 degrees F), dew point 14 degrees C (57 degrees F), altimeter 30.06 inches Hg. Remarks; automated observation...precipitation since 1853 was reported at 0.14 of an inch.

⁴⁰ In meteorology, a trough is an elongated region of relatively low atmospheric pressure, often associated with a front.

The Spirit of St. Louis Airport (SUS), Chesterfield, Missouri (located 23 miles north-northwest of the accident site), special surface weather observation for 1854 was as follows:

wind from 030 degrees at 7 knots, tower visibility 3/4 mile in moderate rain and mist, ceiling broken at 800 feet, temperature 15 degrees C (59 degrees F), dew point 14 degrees C (57 degrees F), altimeter 30.05 inches Hg. Remarks; automated observation, surface visibility 3 miles, ceiling 50 feet variable to 1,300 feet...precipitation since last hour 0.08 inches, 6-hour precipitation 0.79 of an inch.

The SUS special surface weather observation for 1946 was as follows:

wind from 040 degrees at 11 knots, tower visibility 2 mile in light rain and mist, ceiling broken at 800 feet, overcast at 1,400 feet, temperature and dew point 14 degrees C (57 degrees F), altimeter 30.05 inches Hg. Remarks; automated observation, surface visibility 5 miles, ceiling 600 feet variable to 1,100 feet, precipitation since last hourly observation 0.08 inches.

Weather stations surrounding the destination airport (EIW) and the airport to which the pilot asked to be diverted (JEF) were reporting visual meteorological conditions around the time of the accident.

The closest upper air data site was in Springfield, Missouri, located 136 miles southwest of the accident site. The sounding⁴¹ from this site indicated a low-level inversion about 3,500 feet to 5,000 feet, which was saturated up to 8,700 feet with drier air above. The sounding showed a northeast wind flow of 10 to 30 knots from the surface to below the inversion, with winds backing to the north and northwest above the inversion at speeds of 20 to 25 knots. The sounding indicated that the freezing level was 12,654 feet.

WRECKAGE AND IMPACT INFORMATION

The accident site was located in a heavily wooded area near Hillsboro, Missouri. The initial terrain impact occurred along the slope of a heavily wooded hillside. The impact resulted in a crater that measured approximately 10 feet long by 5 feet wide and was approximately 4 feet deep at the center.

Sixteen trees were struck, including a stand of trees that were completely severed along the airplane's path. The remaining trunk of each severed tree was splintered toward the southwest, about 240°. Several trees were contacted before the airplane severed the stand of trees, and the first identifiable tree strike occurred about 144 feet east-northeast of

⁴¹ A sounding is a plot of the vertical profile of temperature and dew point (and often winds) above a fixed location. Soundings are used extensively in severe weather forecasting to determine weather instability, locate temperature inversions, measure the strength of the cap, and obtain convective temperatures.

the impact crater. The distance from the first tree strike to the stand of trees was about 64 feet, and the distance from the stand of trees to the impact crater was about 80 feet. The distance between the impact crater and the furthest piece of wreckage was about 900 feet. An aerial search of the accident site did not reveal any aircraft parts in the area of the flightpath leading to the initial tree impact or in the area beyond the furthest piece of recovered wreckage.

The wing tips, nose, tail, and some or all of the flight control surfaces were found at the wreckage site. The first piece of fuselage wreckage (nose gear door) was located near the first trees in the stand of trees. Pieces of the right wing tip fuel tank were located 120 feet east-northeast of the impact crater in the area of the initial tree strike; pieces of the left wing tip fuel tank were located 45 feet southwest of (past) the impact crater. Portions of the right wing structure were located in line with the flightpath, slightly to the right of the impact crater. Most of the left wing structure was found further southwest of the crater than the right wing structure. A large portion of the left engine was located approximately 300 feet southwest of the impact crater, and it was suspended in a tree about 60 feet from the ground. The right engine crankshaft was located approximately 900 feet southwest of the crater, in the area that marked the southwestern boundary of the debris field.

The wreckage field was divided into 30 zones of various sizes, depending on the aircraft wreckage density. The wreckage was surveyed, documented, and then moved to the Missouri National Guard Armory in Festus, Missouri, for further examination. Approximately 70 to 80 percent of the airplane was recovered. With the exception of the horizontal stabilizers and the aft upper fuselage skin, the airframe structure separated into small (between 6 inches by 6 inches and 12 inches by 12 inches) and medium (between 12 inches by 12 inches and 24 inches by 24 inches) size pieces of debris.

A laser-based measuring device was used to document the accident site. Data from the laser survey were used to create a three-dimensional model of the airplane's flightpath through the trees. The model and the inspection of the accident site revealed that the airplane was in a 16° to 18° right-wing-down attitude during its entry into the trees. (See figure 1.)

No evidence of an in-flight fire or in-flight structural failure was noted. All of the examined fracture surfaces exhibited evidence of overload failure.

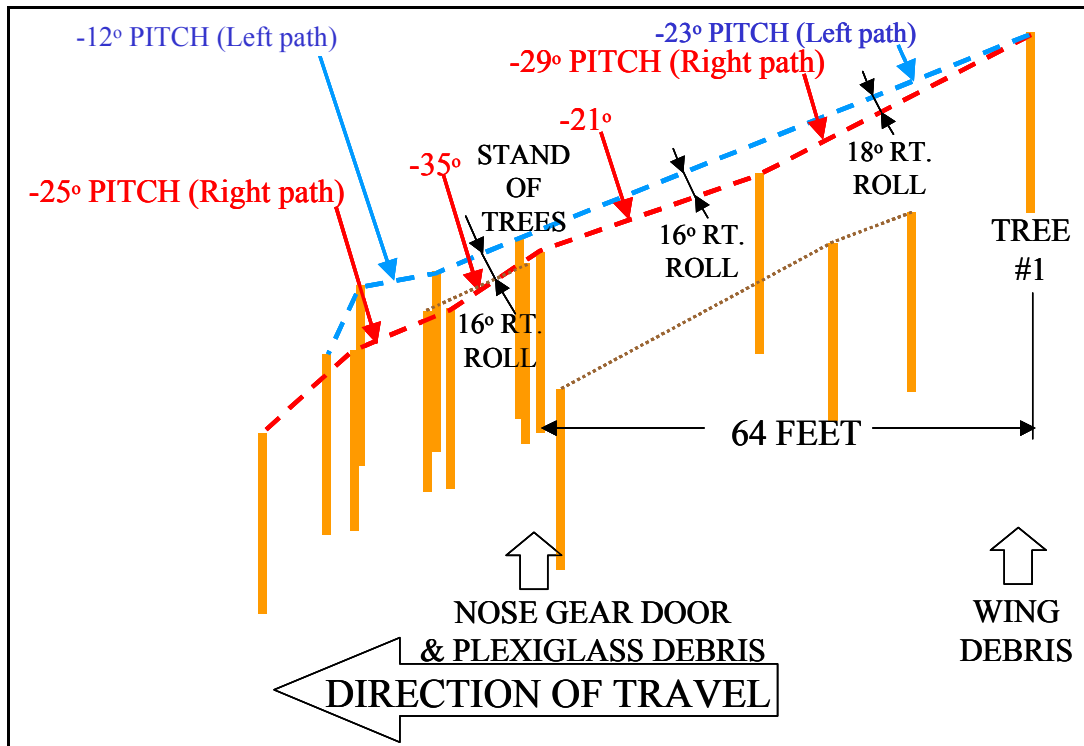

Figure 1. Diagram showing the side-view of the broken tree tops, construction lines that connect the trees along the direction of travel, and attitude lines with respect to a horizontal plane. Each vertical line represents the base and top of a remaining tree.

MEDICAL AND PATHOLOGICAL INFORMATION

Because of the condition of the pilot's remains, no autopsy was performed. Toxicological samples (muscle tissue) from the pilot were sent to the FAA's Toxicology and Accident Research Laboratory, Oklahoma City, Oklahoma, for examination. The pilot's toxicological results were negative for alcohol and drugs.

SURVIVAL ASPECTS

The accident was not survivable.

Emergency Response

A person who lives near the accident site reported the accident to the Jefferson County 911 Dispatch shortly after it occurred.⁴² Members of the Goldman Fire District, the Jefferson County Sheriff's Department, and the Missouri State Highway Patrol responded to the site of the accident. After which time, a search of the local area was

initiated. Because of the condition of the wreckage, the poor weather conditions, the rough terrain, and dark lighting, emergency response efforts were suspended until the next morning.

TESTS AND RESEARCH

Vacuum System and Cockpit Instrument Component Examination

Components and pieces of wreckage identified as being part of the accident airplane's vacuum system and cockpit instrumentation were inspected at the Safety Board's Materials Laboratory in Washington, DC.

Vacuum Gage System Failure Indicator Buttons

Both the left and right vacuum gage system failure indicator buttons (a red plastic spherical cap inside a 1.25-inch-long brass tube) were located. The indicator buttons did not have any markings to indicate with which vacuum pump they were associated. The tip of the end of the red cap on one of the indicators was slightly recessed (.029 inch) from the end of the brass tube, and this position is at almost the fully retracted position. The midportion of the brass tube was slightly flattened, and one side of the tube was bent over the end of the cap. The red cap of the second indicator tube was protruding 0.082 inch beyond the edge of the brass, which is in the midportion of its full extension range. The central portion of the second indicator tube and cap was flattened at almost the same position as the first tube.

Vacuum Check Valve Manifold

Three pieces of the vacuum check valve manifold were found. Two of the pieces were the end caps of the manifold, both of which had B-nuts attached to them. One of the B-nuts was found with a flattened aluminum tube attached. The third piece was the center portion of the manifold. The portion of the data plate that remained on the center section contained no useful markings. Both end caps are normally attached to the center section with rivets; pieces of the rivets were found in the end caps. The internal "flapper-type" check valves and springs were not located.

Left Engine Vacuum Pump

Three pieces of the left engine vacuum pump were found: the mounting flange/pump base, which remained attached to the engine accessory case; the pump housing; and the pump housing back flange. (See figure 2 for a diagram of a Cessna 335 vacuum pump.) Fragments of rotor pieces, between 1 and 2 inches long, were recovered.

⁴² Jefferson County 911 Dispatch received several calls after the accident from people in the area who reported hearing the airplane and/or seeing a fire.

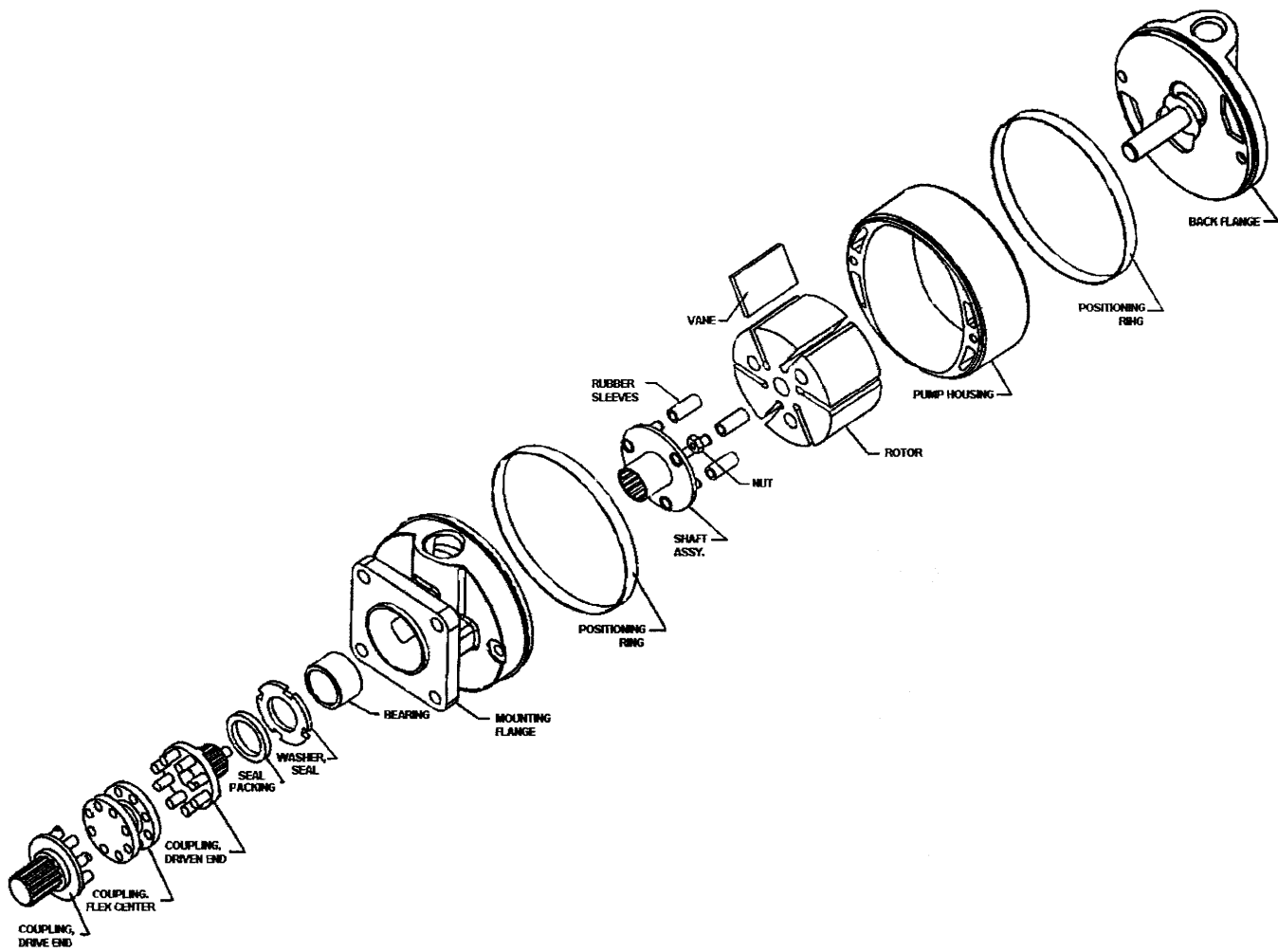

Figure 2. Diagram of a Cessna 335 vacuum pump.

The pieces contained short scratches and gouges in the direction of rotor rotation and other scuff marks and scratches in random directions.

No intact rotor vanes were recovered.

The pump mounting was removed from a fragment of the engine case. The drive shaft end coupling did not rotate when light manual force was applied. After it was disassembled, it was determined that the coupling did not rotate because of a fractured braze⁴³ joint between the shaft assembly and the shaft disc. Examination of the braze joint revealed no evidence of rotational scoring. The drive shaft/coupling assembly was further disassembled. The drive coupling, flex coupling (shear coupling), and driven coupling were intact. Four of the six pin shaft drive pins were bent toward one side (not in the direction of rotation) at varying angles. The pump housing was slightly flattened, and no internal rotational score marks were visible around the circumference. The base of the pump housing contained three marks, which encompassed one half of the circumference. All three marks showed metal dislocation toward the same side of the housing. Once the coupling was removed, the carbon bearing under the base of the pump was found broken on the same side. The outside of the pump housing contained numerous impact marks. Wood and dirt were found embedded within the cooling fins.

Right Engine Vacuum Pump

The right engine vacuum pump was found in two main pieces: the mounting flange and the pump. The drive coupling was found loose from the other components, and two of its pins were missing. The flex coupling (shear coupling) was not recovered. The driven coupling remained attached to the pump assembly and was found intact with pieces of wood embedded between the coupling driven end and the mounting flange. The pump was opened and an even distribution of wear was noted. The interior surface of the drive cap showed no evidence of complete circumferential or lateral marks. Short scratches and gouges were found in the direction of rotation. The rotor was found broken into five major pieces with smaller fragments. The periphery of the rotor was not damaged. The six vanes were found intact with slight chips missing from the outboard corner at the driven end of two of the vanes. The cooling fins sustained impact damage on the side of the pump opposite the OUT port.

Left-Side Attitude Indicator

The following components from the left-side attitude indicator/flight director were identified in the wreckage: the gyroscopic rotor, the rotor case cap, two pieces of the rotor case, the instrument face display (including the roll ring), and pieces of the instrument case frame. (See figure 3 for a photograph of an exemplar attitude indicator and its components.) The model of the attitude indicator installed on the accident airplane contained an arm that provides mechanical linkage from the rotor housing to the pilot's display. This arm was located on a fragment of the instrument case frame.

⁴³ A braze joint is formed by distributing filler metal between closely fitted surfaces through capillary action.

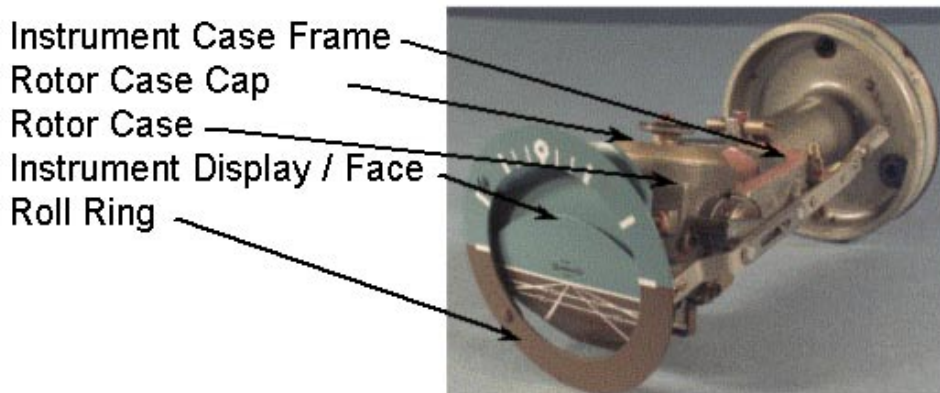

Figure 3. Photograph of an exemplar attitude indicator and its components.

Examination of the interior diameter of the rotor case revealed faint, unevenly spaced diagonal scratches. The measured angle between the scratches and the direction of rotation was between 4.0° and 5.2° . The scratches were consistent with the direction of rotation of the rotor and with the direction the rotor was moving when it exited the case. No other circumferential score marks were found on the inner surface of the case that paralleled the direction of rotation.

Diagonal marks were found on the end of the rotor. Nearly all of the other scratches on the cap were oriented across the direction of rotation at various angles. The center fastener hole on the cap was ripped, with more than half of the periphery remaining. The width of the tears matched the width of the gouges in the rotor. The exterior of the cap contained scratches that resembled the width and approximate locations of the motion-limiting stop wires mounted on an exemplar instrument.

Damage on the facial roll ring resembled the shape of the triangular airplane support housing and the roll index that had been fixed to the instrument case. The relative positions of the damage resembling the triangular support and roll index were on the top and bottom of the ring, respectively, when it was placed at an inverted display of attitude. The face of the instrument was placed behind that of an exemplar instrument and, using the damage on the roll ring for alignment, the marks were within 2° of a wings-level inverted attitude. (See figure 4.)

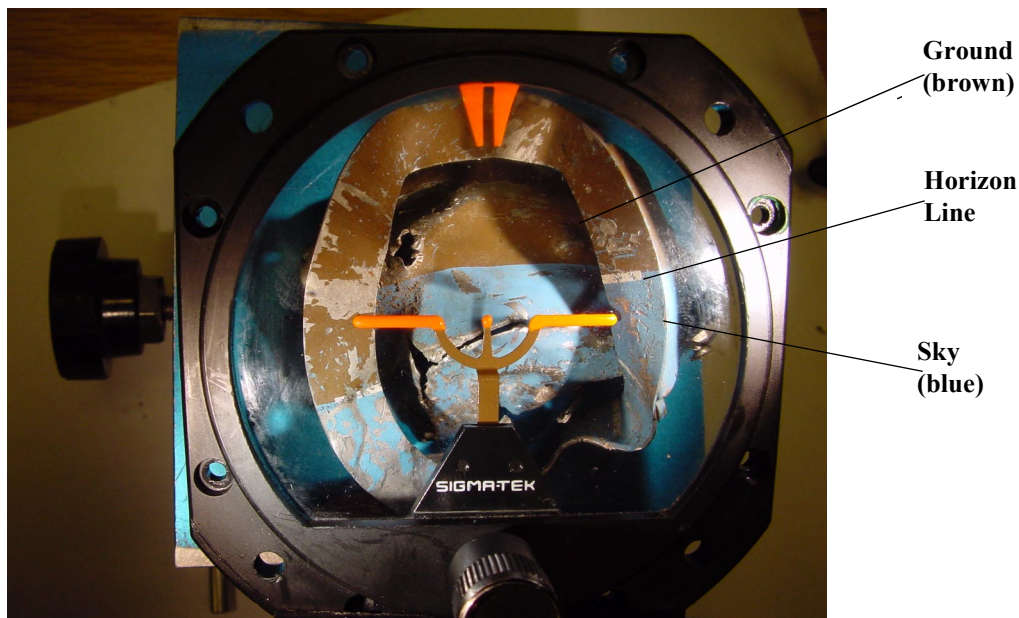

Figure 4. Photograph showing the face of the accident airplane's primary attitude indicator behind that of an exemplar instrument.

Right-Side Attitude Indicator

The following components from the right-side attitude indicator were found: the gyroscopic rotor, the rotor case cap, two pieces of the rotor case, the instrument face display, and portions of the instrument case frame. The instrument display was found separated into three pieces: the football-shaped facial card, the background horizon, and the roll ring.

Two pieces of the rotor case contained light diagonal surface scratches that measured between 2.0° and 5.1° from the direction of rotation. The scratches were consistent with the direction of rotation of the rotor and with the direction the rotor was moving when it exited the case. The lower left corner of the surface contained heavier scuff marks, and the lower edges of the scuff marks were at an angle of about 6° , right end up, from the direction of rotation. A scratch located over the scuffed area was perpendicular to the direction of rotation.

The end of the gyroscopic rotor and the rotor case cap contained light diagonal marks. No complete circumferential marks were found around the surface of the rotor. The interior of the rotor case cap did not contain an imprint of the rotor like the one observed on the cap from the left-side attitude indicator. The material from around the central fastener hole was found displaced to one side, and the cap had an impression on one edge.

Marks on the facial card were matched up with the airplane silhouette in both pitch and roll. Depending on the placement of the airplane, the marks ranged between a 8.4° to 11.8° right-wing-down position at between a -11° to -13° (nose-down) pitch. A paper tracing of the airplane housing cover was moved along the ring. When lined up, one set of marks indicated a 5° right-wing-down position. A second set of pitch-and-roll markings were found on other fragments. The other set of marks were offset to the right of the path that the pitch display would normally travel, and alignment in this plane could only have occurred if the parts had been released from the normal assembly.

Fuel Testing

After the accident, fuel samples were taken from the truck that refueled the accident airplane before its departure from CPS and from the airplane's fuel supply tank. Fuel testing conducted by the Missouri State Highway Patrol Crime Laboratory and Phillips 66 Company revealed no problems with the fuel.⁴⁴

AIRPLANE PERFORMANCE

An aircraft performance study was conducted by the Safety Board using FAA airport surveillance radar data obtained from the St. Louis Lambert International Airport, St. Louis, Missouri, and from the Scott Air Force Base, Belleville, Illinois. Air route surveillance radar data from the FAA's St. Louis Air Route Traffic Control Center and weather data, including winds aloft information, were also used.

At 1920:07, when the pilot first declared that he was having a problem with the airplane's primary attitude indicator, the airplane was climbing through an altitude of 3,000 feet. (See figure 5 for a plot of the ground track for the accident airplane's last 12 minutes of flight.) The calculated indicated airspeed of the airplane during the climb was between 140 and 150 knots. The airplane leveled off slightly and then continued to climb at a slower climb rate as it turned left to a heading of approximately 150° by 1921:10. The airplane remained on this heading for about 2 minutes.

At 1923:55, the St. Louis LW controller instructed the pilot to turn right to a heading of 270°, and, at 1924:04, the controller instructed the pilot to climb to and maintain 7,000 feet. The airplane began the climb and turned right maintaining about a 3.5°-per-second heading change. Calculations show that this turn required an airplane bank angle of 30° and that the airspeed increased to greater than 150 knots. The turn was completed at an altitude of about 5,000 feet, and the airplane continued the climb at 120 knots. By 1928:00, the airplane reached 7,000 feet at a heading of about 300° as the airspeed accelerated to 150 knots. At 1928:30, the airplane began a left turn to the southeast to a heading of about 140° at an altitude that varied between 7,100 and 7,400 feet. The calculated bank angle in the turn was about 25°.

⁴⁴ For more information about the fuel test results, see the Fuel Report in the public docket for this accident.

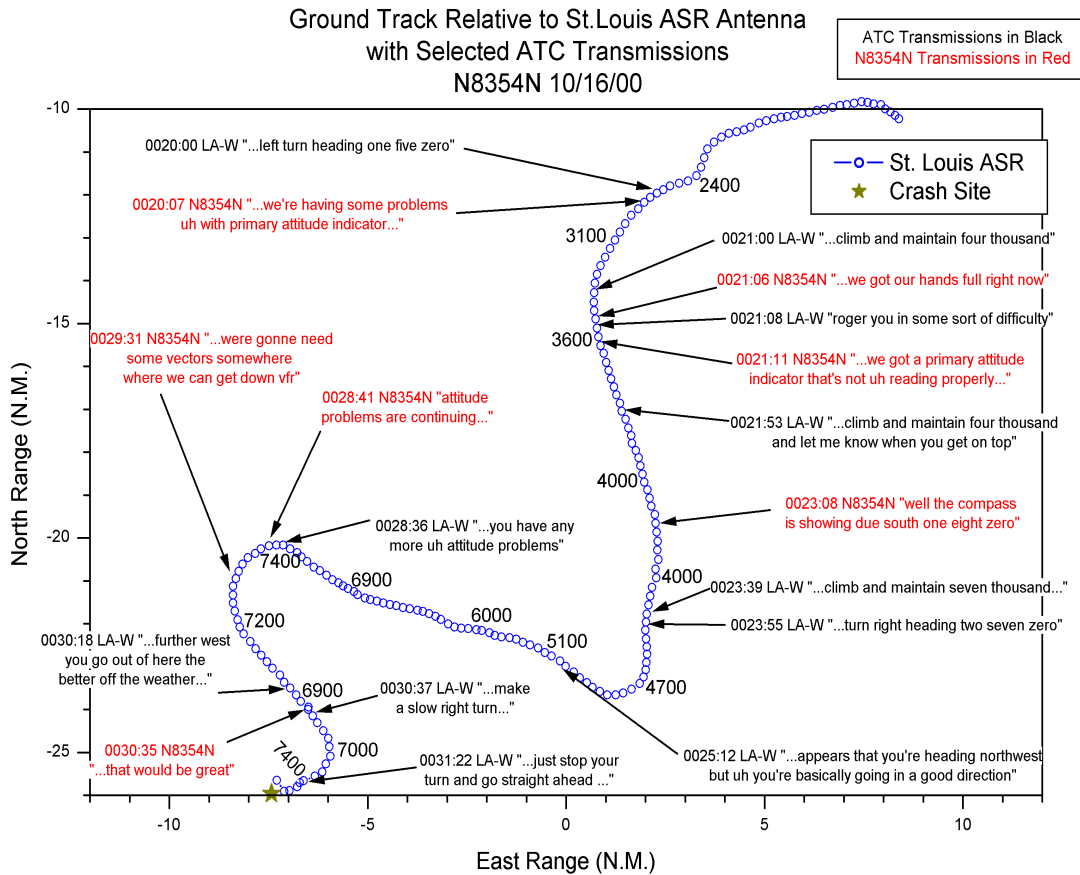

Figure 5. Ground track of the accident airplane's last 12 minutes of flight.

Following the LW controller's instruction to make a slow right turn at 1930:37, the airplane began turning to the right. Calculations reveal that, during the turn, the airplane descended to about 6,800 feet while maintaining an airspeed of about 150 knots. The airplane then descended to about 6,500 feet and then climbed at over 3,000 feet per minute (fpm) for the next several seconds. The airspeed was calculated to be about 120 knots during the climb, with a bank angle of approximately 25°. At 1931:31, the airplane reached its maximum altitude of 7,700 feet.

After reaching 7,700 feet with a calculated pitch angle of 15.5° nose up with a 25° right bank, the airplane began a steep descent. The last radar return occurred at 1931:57, when the airplane was at 2,700 feet. At this point, the calculated descent rate was about 26,000 fpm, the calculated airspeed was greater than 300 knots, and the airplane was at approximately a 60° nose-down attitude.

ADDITIONAL INFORMATION

Spatial Disorientation

One purpose for instrument training and maintaining instrument proficiency is to prevent a pilot from being misled by several types of hazardous illusions that are peculiar to flight. Under IFR conditions, an aircraft's attitude can only be determined accurately by observing and interpreting the flight instruments and rejecting the bodily sensations associated with the aircraft's movement, which can be exacerbated by head movements. Practice and experience in instrument flying are necessary to help pilots ignore or overcome false sensations.

The FAA Instrument Flying Handbook (FAA-H-8083-15) describes one of the major illusions leading to spatial disorientation as follows:

Coriolis Illusion

The pilot has been in a turn long enough for the fluid in the ear canal to move at the same speed as the canal. A movement of the head in a different plane, such as looking at something in a different part of the cockpit, may set the fluid moving, thereby creating the strong illusion of turning or accelerating on an entirely different axis...This action causes the pilot to think the aircraft is doing a maneuver that it is not. The disoriented pilot may maneuver the aircraft into a dangerous attitude in an attempt to correct the aircraft's perceived attitude.

For this reason, it is important that pilots develop an instrument cross-check or scan that involves minimal head movement.

The *Aeronautical Information Manual* (AIM) describes the coriolis illusion as the "most overwhelming of all illusions in flight" and states that it "may be prevented by not making sudden, extreme head movements, particularly while making prolonged constant rate turns under IFR conditions."⁴⁵

Partial Panel and Instrument Meteorological Conditions Flight Training Requirements

The Instrument Airplane Rating Practical Test Standard for 2000 requires that the instrument rating applicant do the following:

- exhibit the knowledge of recognizing whether an attitude indicator and/or heading indicator is inaccurate or inoperative,
- advise anytime the aircraft is unable to comply with a clearance, and

⁴⁵ For more information about illusions leading to spatial disorientation, see AIM, Chapter 8-1-5(b).

- demonstrate a nonprecision instrument approach without gyro attitude and heading indicators.

Title 14 CFR Section 61.57, “Recent Flight Experience: Pilot in Command [PIC],” Paragraph (c), “Instrument Experience,” states that to act as PIC under IFR, or in weather conditions less than the minimums prescribed for VFR, the person must have accomplished the following, within the preceding 6 months:

performed and logged under actual or simulated instrument conditions, either in flight in the appropriate category of aircraft for the instrument privileges sought or in a flight simulator or flight training device that is representative of the aircraft category for the instrument privileges sought --:

- at least six instrument approaches;
- holding procedures; and
- intercepting and tracking courses through the use of navigation systems.^[46]

FAA Procedures and Guidance Regarding ATC Handling of Aircraft in Emergency Situations

FAA Order 7110.65, “Air Traffic Control,” Chapter 10, “Emergencies,” provides controllers with the following guidance on recognizing and handling emergency situations:

10-1-1 Emergency Determinations

An emergency can be either a Distress^[47] or an Urgency^[48] condition as defined in the “Pilot/Controller Glossary.”...If...you are in doubt that a situation constitutes an emergency or potential emergency, handle it as though it were an emergency....Because of the infinite variety of possible emergency situations, specific procedures cannot be prescribed. However, when you believe an emergency exists or is imminent, select and pursue a course of action which appears to be most appropriate under the circumstances and which most nearly conforms to the instructions in this manual.

10-1-2 Obtaining Information

Obtain enough information to handle the emergency intelligently. Base your decision as to what type of assistance is needed on information and

⁴⁶ As stated previously, the Safety Board could not determine if the pilot had met the requirements of 14 CFR Section 61.57.

⁴⁷ The “Pilot/Controller Glossary” defines distress as a condition of being threatened by serious and/or imminent danger and of requiring immediate assistance.

⁴⁸ The “Pilot/Controller Glossary” defines urgency as a condition of being concerned about safety and of requiring timely but not immediate assistance; a potential distress condition.

requests received from the pilot because he/she is authorized by 14 [CFR] Part 91 to determine a course of action.

10-1-3 Providing Assistance

Provide maximum assistance to aircraft in distress. Enlist the services of available radar facilities...as well as their emergency services and facilities, when the pilot requests or when you deem necessary.

Further, FAA Order 7110.65 contains procedures that enable ATC to render assistance by minimizing pilot workload during inadvertent operation in IMC. Specifically, Paragraph 10-2-9, "Radar Assistance Techniques,"⁴⁹ states the following:

Use the following techniques to the extent possible when you provide radar assistance to a pilot not qualified to operate in IFR conditions:

- a. Avoid radio frequency changes except when necessary to provide a clear communications channel.
- b. Make turns while the aircraft is in VFR conditions so it will be in a position to fly a straight course while in IFR conditions.
- c. Have pilot lower gear and slow aircraft to approach speed while in VFR conditions.
- d. Avoid requiring a climb or descent while in a turn if in IFR conditions.
- e. Avoid abrupt maneuvers.
- f. Vector aircraft to VFR conditions.

FAA Order 7110.65 also specifies other procedures and techniques for assisting pilots in difficulty, including "no-gyro" vector procedures, which provide a defined method for controllers to issue heading changes to aircraft that have a defective gyroscopic instrument, such as an attitude indicator. The procedure entails the pilot making turns at no greater than the standard rate when instructed to do so by the controller. Further, instead of providing the pilot with headings to be flown, the controller should observe the radar track and issue control instructions "turn right/left" or "stop turn" as appropriate.

⁴⁹ Although the procedures in FAA Order 7110.65, Paragraph 10-2-9, do not directly apply to situations in which IFR aircraft experience instrument failures, a reasonable and prudent controller would be expected to use such procedures in these situations.

ANALYSIS

General

The pilot received current and adequate weather information before conducting the accident flight.

Instrument meteorological conditions (IMC) prevailed at the time of the accident, which occurred at night in dark lighting conditions, turbulence, and rain.

The pilot was properly certificated and qualified to operate a multiengine airplane in IMC in accordance with applicable Federal regulations. However, because the pilot made no pilot logbook entries during the 6 months preceding the accident, it could not be determined if he met the instrument currency requirements to act as pilot-in-command in IMC.

The airplane was properly certificated and equipped in accordance with Federal regulations and approved procedures.

The pilot remained in contact with air traffic control (ATC) facilities and a transponder code was transmitted to ground-based radar sites throughout the flight, indicating that the airplane did not experience an in-flight electrical failure.

Examination of the airframe and engines did not reveal any preexisting mechanical failures or malfunctions in the structure or powerplants.

There was no evidence that medical issues or pilot fatigue contributed to the accident.

Radar data, ATC transmissions, and other evidence indicate that the pilot lost control of the airplane at 7,700 feet as he was making a climbing right turn.

Examination and distribution of the wreckage revealed that the airplane remained intact and was in an upright attitude when it contacted trees at a velocity of over 300 knots and then impacted rocky terrain.

Role of Malfunctioning Attitude Indicator

The pilot indicated to ATC several times that he was having problems with the airplane's primary attitude indicator. He also told ATC that he was trying to use the right-side attitude indicator, which indicates that the airplane did not experience a total vacuum system failure. Examination of the wreckage revealed rotational marks in the left and right engine vacuum pumps, which indicates that they were most likely functioning at

the time of impact. Further, one of the vacuum gage system failure indicator buttons exhibited evidence of having been in almost the fully retracted position (the other indicator button was found in the partially retracted position), which indicates that adequate vacuum existed for the airplane's instruments to operate.⁵⁰

On the basis of the examination of the left-side (primary) attitude indicator, it was determined that the rotor was most likely spinning, but not at a high enough rpm to keep the display erect (the wreckage fragments of the left-side attitude indicator clearly aligned in an inverted attitude), indicating that this attitude indicator was not displaying properly at the time of impact. Although the pilot reported that his primary attitude indicator had failed and examination of the attitude indicator supported that such a failure had occurred, the investigation could not determine the cause of the failure in that instrument.

On the basis of the examination of the right-side attitude indicator, it was determined that the rotor was spinning, the display was erect when the airplane made initial contact with the trees, and the attitude it displayed was consistent with the airplane's attitude when it struck the trees (as determined by an inspection of the accident site and a three-dimensional model of the airplane's flightpath through the trees), indicating that this attitude indicator was functioning properly until the time of impact.

After first reporting that the primary attitude indicator was malfunctioning, the pilot continued flight for about 11 minutes, including two controlled heading changes, indicating that the pilot had functioning cockpit instruments and that he could control the airplane. Further, in the event that an instrument malfunction occurs, instrument flight rules (IFR)-qualified pilots are trained to use other relevant instruments, which evidence indicates were operating on the accident airplane (the right-side attitude indicator). Therefore, the loss of the primary attitude indicator alone does not explain why the pilot lost control of the airplane and crashed.

However, the right-side attitude indicator was not large and would have been several feet to the right of the pilot. Therefore, using the right-side attitude indicator would have resulted in the pilot making frequent, rapid head movements to cross-check that instrument with the other instruments. The pilot's head movements most likely caused him to experience spatial disorientation. Further, the rain conditions in which the pilot was maneuvering would have increased the noise level in the cockpit, and the presence of turbulence would have made it more difficult to control the airplane with failed instrumentation, both of which would likely have exacerbated the pilot's spatial disorientation.

⁵⁰ Pump tests show that a single vacuum pump can provide adequate pressure and flow capacity if the other pump has become inoperative and the flapper valve has failed in the open position. For more information, see the January 9, 2002, addendum to the Systems Group Chairman's Factual Report.

Air Traffic Controller Actions

The procedures in FAA Order 7110.65, “Air Traffic Control,” Paragraph 10-2-9, “Radar Assistance Techniques,” do not directly apply to situations in which IFR aircraft experience instrument failures. However, a reasonable and prudent controller would be expected to use such procedures in these situations.⁵¹ Pilots who conduct flights under IFR compensate for the absence of visual cues by using aircraft attitude information obtained from instruments such as a heading indicator, an attitude indicator, and a turn coordinator. If these instruments or their power sources fail, it can be difficult for the pilot to maintain control of the aircraft. Services provided by a radar ATC facility can replace some of the information provided by gyroscopic instruments, such as course and turn trend information.

A review of the ATC recording revealed that when the pilot first stated that he was having some problems with the airplane’s primary attitude indicator at 1920:07, a great deal of background noise was also recorded, which made the pilot’s comment unclear and likely prevented the controller from hearing this portion of the pilot’s transmission. During that transmission, the pilot also asked to be assigned a higher altitude, which could be heard clearly on the ATC recording. At 1920:16, the controller responded to this request, stating, “I’ll have a higher climb in about two miles.”

At 1920:11, the pilot again indicated that he was having a problem with the airplane’s primary attitude indicator. At 1921:20, the controller advised the pilot to try and fly the airplane level on any heading and told him that he would try to get him to as high an altitude as possible. The controller’s instructions were prudent for handling an airplane in this situation.

At 1922:50, the pilot made his first request to be diverted to Jefferson City Memorial Airport (JEF). In response, the controller issued the pilot a heading of 120°,⁵² which would not have directed the airplane toward JEF, rather it would have directed the airplane toward EIW. This action and the controller’s postaccident statement that he was surprised when the pilot asked to be diverted the second time (at 1923:46) because he thought the pilot wanted assistance to continue to EIW indicates that the controller did not understand or hear the pilot’s first request. At 1923:39, the controller issued a climb clearance to the pilot, stating, “climb and maintain seven thousand at pilot discretion.” The controller’s use of the phrase, “at pilot discretion,” allowed the pilot to initiate a climb

⁵¹ Specifically, these procedures advise air traffic controllers to avoid requiring an airplane to climb or descend while in a turn if in IFR conditions, avoid issuing abrupt maneuvers, and vector aircraft to visual flight rules (VFR) conditions. Further, FAA Order 7110.65 contains “no-gyro” vector procedures for assisting pilots in difficulty, which state that the air traffic controller should observe the radar track and issue control instructions “turn right/left” or “stop turn” instead of issuing headings to be flown. The procedures also state that the pilot should make turns at the standard rate (3° of heading change per second). Such procedures help minimize the pilot’s workload and head movements (which, as stated previously, can aggravate spatial disorientation).

⁵² The controller’s issuance of a specific compass heading was not an optimal response for assisting an airplane with a gyroscopic instrument problem. However, ATC radar indicate that the airplane continued in a steady, straight climb for several minutes after the controller made this instruction.

at any point or rate that he wished to help prevent him from having to make a climbing turn, which indicates that the controller recognized the seriousness of the situation and used good operating practices for assisting a pilot flying an airplane with instrument difficulty. Radar data indicate that the pilot elected to initiate the climb immediately after receiving the clearance from the controller.

After the pilot's second request (at 1923:46) that he wanted to divert to JEF, the controller responded, stating, "in that case turn right heading two seven zero."⁵³ At 1924:00, the pilot asked the controller to confirm the assigned altitude, and, the controller responded, "climb and maintain seven thousand." Radar data indicate that the airplane continued to climb after this transmission and started the turn that the pilot had requested.

After this exchange, the controller directed his attention to another airplane for about 1 minute. At 1925:12, the controller informed the pilot of N8354N that "you're basically going in a good direction." ATC radar indicate that for about 3 1/2 minutes after this transmission, the airplane flew on a course and at an altitude consistent with the controller's instructions.

At 1928:36, the controller asked the pilot, "you have any more attitude problems," and the pilot responded, "the attitude problems are continuing." ATC radar show that the airplane entered a left turn to the southeast as the pilot was making this statement. At 1929:31, the pilot requested "vectors...[to] get down VFR." During postaccident interviews, the controller stated that he became concerned when the pilot requested vectors to VFR conditions and that, in his opinion, the pilot did not convey a sense of urgency until he made this request. Further, the controller stated that after the pilot made this request, he observed N8354N's target on the radar turn left back into "weather," at which point, he became very concerned.

At 1929:41, the controller instructed the pilot of N8354N to "just go straight ahead...doesn't make any difference what direction that is just go straight ahead." Although the controller did not advise the pilot of the southeasterly turn or attempt to determine why the pilot was deviating from his intended destination (JEF), he did start applying no-gyro vector procedures, which was an appropriate and prudent response. ATC radar show that after the controller made this instruction, the airplane appeared to be stabilized on the southeasterly course at a level altitude for about 1 minute. While on this course, the controller continued to issue no-gyro vector instructions, stating, "make a slow right turn as as much as you can the standard rate." ATC radar data indicate that the airplane started to make a slow right turn after this instruction. At 1931:22, the controller continued issuing no-gyro vector instructions, stating, "just stop your turn and go straight ahead you're doing fine." ATC radar show that, shortly thereafter, the airplane began its rapid descent.

⁵³ Again, the controller's issuance of a specific compass heading was not an optimal response in this situation. However, ATC radar again indicate that the airplane continued in steady, straight flight after the controller made this turn instruction.

In summary, although the controller continued to issue specific compass heading instructions to the pilot after he determined that the airplane's primary attitude indicator was malfunctioning at 1920:11, ATC radar data show that the pilot made the turns as instructed and flew straight and level for several minutes after making the turns. Therefore, the Safety Board determined that these turn instructions did not cause or contribute to the pilot's spatial disorientation. Further, although the controller did not give the pilot the information about his southeasterly heading or try to determine why the pilot made the turn and given that the pilot responded to the controller's instructions, the Board determined that this omission did not cause or exacerbate the pilot's spatial disorientation. Therefore, the controller's actions were not considered to be a contributing factor.

Probable Cause

The National Transportation Safety Board determines that the probable cause of this accident was the pilot's failure to control the airplane while maneuvering because of spatial disorientation. Contributing to the accident were the failure of the airplane's primary attitude indicator and the adverse weather conditions, including turbulence.