

---

## Partial-gear landing, Airbus A340-311, G-VSKY

---

**Micro-summary:** This Airbus A340-311 landed with the landing gear partially extended.

---

**Event Date:** 1997-11-05 at 1620 UTC

**Investigative Body:** Aircraft Accident Investigation Board (AAIB), United Kingdom

**Investigative Body's Web Site:** <http://www.aaib.dft.gov/uk/>

**Note:** Reprinted by kind permission of the AAIB.

---

### Cautions:

1. Accident reports can be and sometimes are revised. Be sure to consult the investigative agency for the latest version before basing anything significant on content (e.g., thesis, research, etc).
  2. Readers are advised that each report is a glimpse of events at specific points in time. While broad themes permeate the causal events leading up to crashes, and we can learn from those, the specific regulatory and technological environments can and do change. ***Your company's flight operations manual is the final authority as to the safe operation of your aircraft!***
  3. Reports may or may not represent reality. Many many non-scientific factors go into an investigation, including the magnitude of the event, the experience of the investigator, the political climate, relationship with the regulatory authority, technological and recovery capabilities, etc. It is recommended that the reader review all reports analytically. Even a "bad" report can be a very useful launching point for learning.
  4. Contact us before reproducing or redistributing a report from this anthology. Individual countries have very differing views on copyright! We can advise you on the steps to follow.
-

# Airbus A340-311, G-VSKY: Main document

Aircraft Accident Report No: 4/2000 (EW/C97/11/1)

## Report on the accident to Airbus A340-311, G-VSKY at London Heathrow Airport on 5 November 1997

- [Synopsis](#)
- [1 Factual Information](#)
- [1.1 History of the flight](#)
- [1.2 Injuries to persons](#)
- [1.3 Damage to the aircraft](#)
- [1.4 Other damage](#)
- [1.5 Personnel information](#)
- [1.6 Aircraft information](#)
- [1.7 Meteorological information](#)
- [1.8 Aids to navigation](#)
- [1.9 Communications](#)
- [1.10 Aerodrome information](#)
- [1.11 Flight recorders](#)
- [1.12 Aircraft and runway examination](#)
- [1.13 Medical and pathological information](#)
- [1.14 Fire](#)
- [1.15 Survival aspects](#)
- [1.16 Tests and research](#)
- [1.17 Organisational and management information](#)
- [1.18 Additional information](#)
- [1.19 New investigation techniques](#)
- 2 Analysis
- [2.1 Operation of the aircraft](#)
- [2.2 The landing gear malfunction](#)
- [2.3 Possible failure modes of torque pin retention](#)
- [2.4 Flight recorders](#)
- 3 Conclusions
- [3\(a\) Findings](#)
- [3\(b\) Causal factors](#)
- [4 Safety recommendations](#)
- 5 Appendices
- Appendix 1 - QRH Landing Gear Gravity Extension procedure
- Appendix 2 - QRH Landing with Abnormal Landing Gear procedure
- - Figure 1
- - Figure 2
- Appendix 3 - FCOM Landing with Abnormal Landing Gear procedure
- - Figure 1
- - Figure 2
- - Figure 3
- Appendix 4 - G-VSKY on runway 27L
- Appendix 5 - Jammed landing gear with rod trapped in keel beam
- - Figure 1

- - Figure 2
- Appendix 6 - View of the departure end of the runway at Los Angeles
- Appendix 7 - No. 6 torque pin recovered from Los Angeles
- Appendix 8 - Damage to keel beam ancillary structure
- Appendix 9 - Post Flight Reports
- Appendix 10 - Schematic diagram of the A340 hydraulic system
  - - Figure 1
  - - Figure 2
  - - Figure 3
- Appendix 11 - RAT performance, logic, flow limits
- Appendix 12 - Electrical power schematic
- Appendix 13 - PRIM & SEC flight computer supplies and command paths
  - - Figure 1
  - - Figure 2
- Appendix 14 - Brake pack and torque pin assembly fitted to G-VSKY
  - - Figure 1
  - - Figure 2
  - - Figure 3
- Appendix 15 - Torque pins, EIS and IGW and redesigned versions
  - - Figure 1
  - - Figure 2
  - - Figure 3
  - - Figure 4
- Appendix 16 - FDR data
- Appendix 17 - Layout of Heathrow Airport
- Appendix 18 - Metallurgical report extract on torque pins and retention
  - - Figure 1
  - - Figure 2
- Appendix 19 - Metallurgical report extract on brake piston housing bore damage
  - - Figure 1
  - - Figure 2
  - - Figure 3
  - - Figure 4
- Appendix 20 - Loads in pin and bolt due installation, braking and turning
  - - Figure 1
  - - Figure 2
- Appendix 21 - Door performance tests
  - - Figure 1
  - - Figure 2
  - - Figure 3
  - - Figure 4
- Appendix 22 - AIP RFF Category comparison
  - - Figure 1
  - - Figure 2
- Appendix 23 - Calculated crosswind loss of control speeds
- Appendix 24 - Brake rod restraint
- Appendix 25 - Ground clearance diagram
- Appendix 26 - UK Airport Movement Statistics 1997
- Appendix 27 - Revised QRH Landing with Abnormal Landing Gear procedure
  - - Figure 1

- - Figure 2

Registered Owner and Operator: Virgin Atlantic Airways Ltd  
Aircraft Type: Airbus Industrie A340-311  
Nationality: British  
Registration: G-VSKY  
Place of Accident: Runway 27L, London Heathrow Airport  
Date and Time: 5 November 1997 at 1620 hrs  
All times in this report are UTC

- **Synopsis**

- The accident was notified to the Air Accidents Investigation Branch (AAIB) at 1630 hrs on 5 November 1997 by Airfield Operations at London Heathrow Airport and the investigation began immediately. The investigation was conducted by Dr E J Trimble (Investigator-in-Charge), Mr P D Gilmartin (Operations), Mr A P Simmons (Engineering) and Ms A Evans (Flight Recorders).
- The accident occurred when the aircraft, which had a landing gear problem on its first approach to Heathrow Airport, carried out an emergency landing on Runway 27L with the left main landing gear only partially extended. The flight crew responded to the in-flight emergency with commendable judgement and conducted a skilful landing, with the Airport Emergency Services in full and effective attendance. The evacuation was completed with minor injuries to 5 passengers and 2 crew members.
- Examination of the left main landing gear found that the gear had been jammed by the No 6 wheel brake torque rod which had disconnected from its brake pack assembly and had become trapped in the keel beam structure. The associated torque rod pin was subsequently found beyond the end of Runway 24L at Los Angeles International Airport, the departure airport.
- The investigation identified the following causal factors:
  - 1 Full deployment of the left main landing gear was prevented by the unrestrained end of the No 6 brake torque rod having become trapped in the keel beam structure within the gear bay, jamming the landing gear in a partially deployed position.
  - 2 The torque pin which had connected No 6 brake torque rod to that wheel brake assembly had disengaged during landing gear retraction after take off from Los Angeles, allowing the unrestrained rod to pivot freely about the retained end.
  - 3 The torque pin and its retaining assembly had been subject to higher axial and torsional loads than predicted during aircraft braking in service. These loads were the result of elastic deformation of the wheel axle, brake and torque rod, and due to assembly without the correct axial clearance as a result of prior undetected displacement of the associated bushes. The precise mode of failure of the retaining assembly bolt, nut and cotter pin could not be ascertained in the absence of these parts.
  - 4 This design of wheel brake assembly had satisfactorily passed the related certification wheel brake structural torque test to the requirements of TSO C26c paragraph 4.2(b). However the latter contained no requirement to use a representative axle or other means to reproduce the axle deflections which occur during aircraft braking in service, and

did not require post-torque test strip assessment of brake assemblies for resultant evidence of overstressing deformation which did not produce component failure.

- Six safety recommendations have been made as a result of this investigation.
- **1 Factual information**
- **1.1 History of the flight**
- The aircraft was operating a scheduled passenger service from Los Angeles International Airport to London Heathrow Airport. There were three flight deck crew, one flight deck supernumerary passenger, 13 cabin crew and 97 passengers on board. There were no abnormalities noted prior to departure and the aircraft had no significant deferred defects recorded in the Technical Log.
- The crew had reported for duty at 0330 hrs (1930 hrs local time) for a planned 0450 hrs departure. The aircraft pushed back from stand 27 at Los Angeles at 0455 hrs. The crew later recalled that several tight turns had been made during the push-back and taxi phases, but this was not considered abnormal. The aircraft taxied via taxiways D9 and E for a departure from Runway 24L.
- After take off at 0509 hrs, the landing gear appeared to take a little longer than usual to complete the retraction process, but there were no abnormal indications or alert messages displayed to the crew and the hydraulic system quantity indications were normal. (Certain warnings concerning the status of the landing gear, particularly Gear DOORS NOT CLOSED and SYSTEM DISAGREE parameters, are inhibited from being displayed to the crew while the aircraft is below 1,500 feet agl).
- The flight proceeded uneventfully but during the cruise phase, as part of a routine scan of the aircraft systems, it was noted that the No 6 brake temperature indication (corresponding to the inboard rear wheel on the left main landing gear) on the Electronic Centralised Aircraft Monitoring (ECAM) 'WHEEL' page showed 'XX' indicating that this parameter was unserviceable.
- A Cruise Relief Pilot (CRP) was part of the crew complement and each of the two operating pilots was able to take a 'bunk' rest period of about 3 hours between 0800 and 1400 hrs. Using this method, in accordance with the operator's Flight Time Limitations scheme, the maximum allowable Flight Duty Period could be extended from 12 hrs to 13.5 hrs, based on the crew complement, acclimatised to local time for a single sector operation.
- The flight continued normally until the aircraft was about 8 nm on final approach to Runway 27R at London Heathrow Airport at 1504 hrs when, on selection of landing gear down, a left main gear unsafe alert was annunciated on the flight deck. The landing gear alert condition persisted and so the first officer, who was the handling pilot for the sector, initiated a go-around from about 2.5 nm and the aircraft was given radar vectors in order to return to the holding fix at Bovingdon VOR.
- Once established in the hold, the crew commenced the 'Landing Gear Gravity Extension' procedure from the aircraft Quick Reference Handbook (QRH) as shown in Appendix 1. The company Operations Department were informed of the situation on the company operations VHF frequency. In consultation with company fleet management and engineering specialists, the crew attempted to rectify the landing gear problem by various means, including resetting the Landing Gear Control & Interface Units (LGCIU's) and relevant circuit breakers (nosewheel steering and landing gear), both on the flight deck and in the underfloor Electronic Equipment Bay. However all attempts to lower and lock down the left main landing gear were unsuccessful.
- As the crew had no means of inspecting the main landing gear from within the aircraft, it was decided to perform a low flypast at Heathrow in order that the landing gear status could be assessed from the ground. A company engineer was positioned in the Control Tower to observe the flypast. The commander took over the aircraft handling for the remainder of the

flight. The aircraft was given radar vectors for an Instrument Landing System (ILS) approach to Runway 27R and the aircraft was then flown over the airport central area in order to fly past the Tower with the underside of the aircraft exposed to view. Prior to this, all of the available procedures were used to extend as much of the landing gear as possible, using the normal checklist and the QRH 'Gravity Extension' procedure.

- It was subsequently assessed from the Control Tower that the left main landing gear was 'hanging in the bay', only partly deployed.
- ATC relayed a request from the observing engineer that the aircraft make a second low flypast. The commander indicated that it would be possible to bring the aircraft around in a 'dumb-bell' pattern to perform a flypast in the opposite direction, but this manoeuvre would have conflicted with the flight path of an aircraft which was departing from Runway 27L at that time and this course of action was therefore not accepted by ATC.
- At this stage, fuel 'low level' alerts were being generated for the inner wing tanks, indicating a total fuel quantity of about 5,400 kg. With this fuel state, the commander did not consider it prudent to conduct another full pattern for an ILS and flypast. However, it was decided to attempt to manoeuvre the aircraft in order to apply some additional 'g' loading to the aircraft in an attempt to assist the left main landing gear to deploy fully, but the subsequent manoeuvring had no apparent effect.
- A 'touch-and-go' landing on the right main gear was also considered to encourage the left main landing gear to be shaken free. However, because of the relatively low fuel state and the fact that the commander had never practised this type of manoeuvre in a simulator, it was not attempted.
- The cabin crew had been kept fully informed of the situation by the flight deck crew, and the passengers had been briefed to expect the low flypast. The briefing regarding the manoeuvring occurred just as it was taking place. After all efforts to lower the left main landing gear had been exhausted, the cabin crew was briefed to expect an emergency landing with a planned evacuation after coming to a halt on the runway. The passengers were then briefed to adopt the brace position immediately they received a loud instruction to brace from the cabin crew.
- During the early attempts to lower the landing gear, the company's operations management had arranged for a possible diversion in order that the aircraft could land at Manston (Kent International Airport). Arrangements were made to have the emergency services brought to a state of operational readiness in the event that the aircraft diverted there. The fire and rescue service was brought up to Royal Air Force (RAF) Category 7, the highest available category (approximately equivalent to CAA Category 6) within 30 minutes of the request being made. In the event, because of the fuel quantity available, the crew's familiarity with Heathrow Airport and the availability of all facilities, the commander elected to remain at Heathrow for the final landing rather than to divert to Manston.
- When the aircraft fuel quantity monitoring system indicated an impending low fuel state, the commander decided to position the aircraft for a final landing and formally declared a 'Mayday' emergency status at 1608 hrs. Runway 27L was offered by Heathrow Airport Ltd (HAL) and ATC so that the potential contact by the left engine pods on the runway after the landing would tend to cause the aircraft to veer away from the central area and terminal buildings. It was also suggested to the commander by the operator's fleet manager that the aircraft be landed on the right side of the runway in order to provide the maximum available runway surface to the left of the aircraft for use in the event of the anticipated swing to the left as the aircraft decelerated.
- The CRP reminded the commander about the status of the centre landing gear which was still extended, having been deployed during the performance of both the Normal and 'Gravity Extension' Checklists prior to the flypast. The commander requested an orbit on

base leg in order to provide additional time to perform the QRH procedure 'Landing with Abnormal Landing Gear' (Appendix 2). The gear was retracted and the QRH procedure was recommenced from the beginning in order to ensure that all of the necessary actions had been completed in the correct order and that the aircraft was in the correct configuration for landing with the left main landing gear unsafe. It was noted that landing with one main landing gear retracted would also preclude the deployment of the centre landing gear. This point was detailed in the notes in the Flight Crew Operating Manual (FCOM), Volume 3 (see Appendix 3), but was not detailed in the QRH or on the ECAM Checklist.

- The commander had reviewed the 'Landing with Abnormal Landing Gear' procedure in the QRH. The manufacturer's procedure called for the crew to shut down all engines just prior to touchdown. However the commander elected to modify this procedure and briefed the crew to shut down engine Nos 1 and 4 on initial touchdown (by selecting the Engine Master Switches to OFF), then to shut down engine No 2 on his command, and then finally to shut down engine No 3 as the aircraft settled down onto its left side during the landing roll. The CRP was briefed to perform this task on the commander's instruction.
- The cabin crew was briefed to expect the final approach and landing with the left main landing gear up. The Standard Operating Procedures (SOP's) called for notification of impending touchdown at 1,000 feet agl, followed by a call of 'Brace, Brace' at 200 feet agl. The cabin crew procedure was to call loudly to the passengers to adopt the brace position immediately upon receipt of this call.
- The final approach was flown manually by the commander with the aircraft stabilised on the ILS for Runway 27L. Full flap was used for the landing. On touchdown, the commander called for engine Nos 1 and 4 to be shutdown as previously briefed. During the commander's attempt to keep the left wing raised for as long as possible, the aircraft banked to the right, pivoting about the right main landing gear. As a result the No 4 engine pod scraped the runway briefly, emitting a short burst of sparks, before the aircraft began to settle down on its left side. The No 2 engine was then shut down during the landing roll, followed by the No 3 engine. The contact between the Nos 1 and 2 engine pods and the runway surface generated friction sparking and a very brief fire as the aircraft slowed down. During the landing roll all four tyres on the right main landing gear burst and subsequently the wheels broke up. Major damage was sustained to the brakes and structure of the right main landing gear as the aircraft decelerated.
- During the final stage of the deceleration, the nosewheel castored to the left and the aircraft began a slight left turn as it came to rest on the runway. Appendix 4 shows the final position of the aircraft on the runway. This photograph was taken on the following morning after the aircraft had been jacked, before it had been moved.
- As soon as the aircraft had stopped, crew liaison with the attending fire services confirmed that no fire was present. The engine and APU Fire pushbuttons were operated and the extinguishers were discharged into each engine as a precaution. The commander also ordered the immediate evacuation of the passengers. The cabin crew procedures had been followed as planned and there were no injuries from the touchdown and landing phase. The cabin crew commented that the cabin emergency lights came on briefly during the touchdown phase, but then remained off throughout the subsequent evacuation.
- Most of the doors and evacuation slides deployed normally. The exceptions commented upon by the cabin crew were: the L1 (Left forward) door, which needed an extra push to open it, as though there was no pneumatic power assistance in operation, and which required manual slide inflation; the R2 (Right mid-forward) door, which required manual slide inflation; and the R4 (Right rear) door, which apparently required assistance from cabin crew and passengers to push it open.

- The Airport Emergency Services had been alerted to the emergency in advance of the final landing and were fully deployed in position as the aircraft touched down. The minor friction fires which occurred during the landing were not sustained, however foam extinguishant was discharged under and around the aircraft after it had come to rest as a precaution. The Airport Fire Service personnel also assisted in gathering the passengers into two main groups, from where the airport authority evacuee recovery procedure was implemented successfully.
- Subsequent examination of the left main landing gear found that it was jammed by the No 6 brake torque rod which had become trapped in the keel beam structure (Appendix 5) and that the torque pin retaining the rod at the brake end was not present, allowing the unrestrained rod to pivot about the retained end.
- A later search conducted at Los Angeles International Airport was successful in finding the missing torque pin in the area between the end of the departure Runway 24L and the Pacific shoreline, close to the Airport (Appendices 6 and 7). However, the retaining hardware was not found.
- **1.2 Injuries to persons**

	Crew	Passengers	Others
Fatal	-	-	-
Serious	-	-	-
Minor	2	5	-
None	14	93	N/A

- Seven occupants were taken to hospital for treatment of minor injuries sustained during the evacuation.
- **1.3 Damage to the aircraft**
- The aircraft sustained major damage to the right main landing gear, including the brakes, wheels and tyres. The undersides of the Nos 1, 2 and 4 engine pods contacted the runway surface during the landing and sustained abrasion damage. There was permanent deformation of the structure adjacent to the No 2 pylon, which had taken the majority of the vertical load as the aircraft came to rest. This had caused a minor fuel leak from the wing in the vicinity of the No 2 pylon, although due to the low fuel state this was not apparent until later when the aircraft was being repaired. In addition, all four engines were presumed to have been shock loaded and were removed for inspection and/or overhaul. The Nos 1 and 2 engines had suffered some damage to their gearboxes. The inboard main gear doors had been destroyed by contact with the runway surface while open. All the landing gears, except the centre gear which had been retracted, were removed for overhaul as a precautionary measure. Some damage to the keel beam and adjacent systems had been caused by the mechanical interference between the No 6 brake torque rod and the keel beam (see Appendix 8).
- **1.4 Other damage**
- The surface of Runway 27L was deeply grooved from the point where the right main landing gear tyres had burst to where the aircraft had come to rest. Several runway lights and covers had been broken.
- **1.5 Personnel information**



- 1.5.1 Commander: Male, aged 40 years  
Licence: Airline Transport Pilot's Licence  
Aircraft ratings: Airbus A340, Boeing 707, Shorts Belfast, Handley Page Herald  
Instrument rating: 17 April 1997, valid  
Last base check: 17 April 1997  
Last line check: 6 August 1997  
Medical certificate: Class 1, issued 20 May 1997, valid  
Flying experience: Total all types - 14,486 hours  
Total on type - 2,920 hours  
Total last 90 days - 256 hours  
Total last 30 days - 74 hours  
Total last 24 hours - 12 hours  
Previous rest period - In excess of 48 hours
- 1.5.2 First officer: Male, aged 32 years  
Licence: Airline Transport Pilot's Licence  
Aircraft ratings: Airbus A340, A320, Fokker 100,  
Handley Page Herald  
Instrument rating: 11 April 1997, valid  
Last base check: 20 September 1997  
Last line check: 24 July 1997  
Medical certificate: Class 1, issued 12 February 1997, valid  
Flying experience: Total all types - 4,655 hours  
Total on type - 301 hours  
Total last 90 days - 187hours

Total last 30 days - 46 hours

Total last 24 hours - 12 hours

Previous rest period - In excess of 48 hours

1.5.3 Cruise relief pilot: Male, aged 28 years

Licence: Airline Transport Pilot's Licence

Aircraft ratings: Airbus A340, Boeing 737-300, Boeing 757/767, Cessna 310 series

Instrument rating: 5 June 1997, valid

Last base check: 7 July 1997

Last line check: 24 August 1997

Medical certificate: Class 1, issued 24 March 1997, valid

Flying experience: Total all types - 4,650 hours

Total on type - 289 hours

Total last 90 days - 226 hours

Total last 30 days - 90 hours

Total last 24 hours - 12 hours

Previous rest period - In excess of 48 hours

- During their debrief by the AAIB, all three pilots were asked if they considered that the length of their flight duty period had had any effect on their capacity to handle the emergency situation that developed prior to landing. None of them considered that the long duty period had affected their performance.
- 1.5.4 Training records
- The simulator training records were obtained for each of the three pilots. They had all completed exercises involving problems with landing gear deployment, all of which had been resolved by application of the QRH 'Gravity Extension' and other Checklist procedures. None of them had practised a landing with any one of the main landing gears retracted.
- 1.5.5 Cabin crew training
- The 13 cabin crew members had all undertaken the operator's standard aircraft safety training courses on initial recruitment. All had completed an annual refresher check on the A340 type within the twelve months preceding the accident. The operator was in the process of providing Crew Resource Management training courses for all cabin crew members and all but two of those involved had completed this initial training within the

twelve months prior to this accident. Refresher fire training courses had also been carried out by the cabin crew members. Full training records for each crew member were available for the investigation.

- **1.6 Aircraft information**

- 1.6.1 Leading particulars

Manufacturer:	Airbus Industrie
Type:	A340-311
Constructor's No:	MSN 016
Year of Manufacture:	1993
Certificate of Registration:	First registered 21 January 1994
Certificate of Airworthiness:	Certificate No. 043882/002 valid from 21 January 1997 until 20 January 2000, issued by the CAA
Total airframe hours since new:	19,323
Total flight cycles since new:	2,104
Engines:	Four CFM 56-5C2 turbofan engines

- 1.6.2 Aircraft weights and centre of gravity

Zero fuel weight:	156,366 kg
	(Maximum allowable 174,000 kg)
Taxi weight on departure from Los Angeles:	231,866 kg
Take-off weight at Los Angeles:	231,366
	(Maximum allowable 257,000 kg)
Take-off centre of gravity:	30.4% R.C. (approximate mid position in the allowable range)
Approximate landing weight at Heathrow:	158,000 kg
	(Maximum allowable 186,000 kg)
Landing centre of gravity:	30.8% R.C.

- 1.6.3 Maintenance records

- The aircraft had undergone a Check 1A on 6 October 1997 at 18,887 airframe hours / 2,066 flight cycles, at which time the hours in the Technical Log carried on the aircraft had been reset to zero. A 400 hour check had been carried out on 1 November 1997 at 367.55 hours. The Certificate of Maintenance Review was issued on 3 September 1997 and was valid for 4 months, until 2 January 1998. The Technical Log also showed that wheel No 7 brake temperature indication problems had been reported on several occasions during November and that a tyre pressure intermittent indication problem at wheel position No 8 had been reported on 17 October 1997; otherwise there were no recent entries related to the landing gear in the aircraft Technical Log.
- The brake pack fitted to the No 6 wheel on G-VSKY had been removed from the No 7 wheel on G-VFLY during April 1997, because of a hydraulic leak, and after repair by the manufacturer it had been installed on G-VSKY during May 1997. It carried the serial number SEP91-0039 and its life, in terms of cycles (landings) in each position as it had been rotated around the fleet, is given in the following table:

Position	Cycles	Aircraft
04	313	G-VFLY
05	392	G-VAEL
07	356	G-VFLY
06	250	G-VSKY

- Also of interest later in the investigation was another brake pack, serial APR94-0111, which had been involved in another incident at Hong Kong. Its history is shown below:

Position	Cycles	Aircraft
01	7	G-VFLY
02	590	G-VSUN

- 1.6.4 Post-Flight Reports
- The aircraft systems automatically log certain defects and events and these can be downloaded in the form of a Post-Flight Report. A number of Post-Flight Report items were logged and the most significant of these are discussed later within the flight data recorder section 1.11.
- 1.6.5 Aircraft systems information
- 1.6.5.1 Hydraulic power
- Appendix 9 shows a schematic diagram of the hydraulic system. The aircraft has independent Green, Blue and Yellow hydraulic systems. Normal system operating pressure is 3,000 psi. Any pressure below 1,450 psi represents a failure condition. The systems are monitored by the Hydraulic Systems Monitoring Unit (HSMU). Each system has its own reservoir and an accumulator which serves to reduce pressure surges; these accumulators are not intended to provide useful capacity once power to the hydraulic pumps is lost although the Blue system also has a brake accumulator which provides pressure for the Alternate brake system and also pressure for the parking brake. Hydraulic pressure and flow may be generated by various means as follows:

- *Engine-driven hydraulic pumps (EDP)*: Green system pressure is generated by EDPs on the No 1 and No 4 engines; Blue system is pressurised by the No 2 EDP; Yellow system is pressurised by the No 3 EDP. The EDPs nominally deliver a flow rate of 175 litres per minute at nominal cruise engine speed. These pumps will continue to deliver pressure for about 25 to 30 seconds after engine shutdown is initiated, ie while the engine is running down, unless the engine is shut down using the Fire Push Button, in which case the Hydraulic Shut-Off Valve (HSOV), also called the 'Fire valve', is closed immediately thus isolating the pump.
- *Electric hydraulic pumps*: The A340 type was originally equipped with three such pumps, one for each hydraulic system. Each pump, and its associated system, performed specific tasks in the event of loss of the relevant EDP, however redundancy for certification purposes was provided not by the electric hydraulic pumps, or the ram-air turbine (see later), but by the four-engined configuration of the A340.
- An electric hydraulic pump had originally been fitted to the Green system (see later) to supplement the two EDPs. Its function, as controlled by the HSMU, was to supplement engine No 1 or No 4 to provide adequate flow for gear retraction following engine failure during take off (25 seconds limit), and to provide braking and steering with engines Nos 1 and 4 shut down, but with both Nos 2 and 3 running. The Blue system, normally pressurised by the No 2 EDP, was also previously fitted with an electric hydraulic pump (see later). There was no other means provided to pressurise the Blue system. The Yellow system, normally pressurised by the No 3 EDP, was also fitted with an electric hydraulic pump. This pump was intended to assist flap retraction in the event of a No 3 engine failure, and to allow ground operation of the cargo doors. A hand pump was also provided to operate the cargo doors.
- *Ram Air Turbine*: The Green system can also be pressurised by the Ram Air Turbine (RAT) in an emergency. RAT delivery pressure typically varies from 110 to 180 bar (1600 to 2600 psi). The system is certified down to an indicated airspeed of 140kt and below that flow varies with airspeed as follows:

140 kt:	40 litres/minute at 180 bar
	65 litres/minute at 110 bar
130 kt:	30 litres/minute at 180 bar
	49 litres/minute at 110 bar
125 kt:	26 litres/minute at 180 bar
	42 litres/minute at 110 bar

- Further information concerning RAT performance, functions, limit speed and logic is shown at Appendix 10. All the flying control surfaces for the elevators, rudder and ailerons, at full activity at maximum rate, require 30 litres per minute. The rudder alone requires 7.3 litres/minute. When the RAT is deployed, a flow limit is imposed to maintain pressure, and this provides a limitation on the control surface activity rate and volume. This limit is invoked even if there are engines running and supplying adequate hydraulic power.
- The electric hydraulic pumps for the Green and Blue systems had been temporarily removed from the A330 and A340 fleets by Airbus Industrie, due to two previous events which had raised serious concerns about fire hazards associated with these pumps.

However, because the electric hydraulic pump on the Yellow system was considered essential for operation of both cargo doors it had been replaced with a pump of different design, used as standard on the Airbus A320. This pump was of somewhat lower capacity than the original pump design for the A340.

- Five related Service Bulletins (SBs) had been issued by the aircraft manufacturer requiring the removal of the existing pumps, the fitment of an A320 type pump to the Yellow system and the fitment of ground service equipment pumps to the Blue and Green systems. These SBs had been embodied simultaneously during regular maintenance on this operator's A340 fleet, all of which had been modified to this temporary standard by 14 August 1997. (Since that time, further SBs have been issued to require the fitting of A320 type pumps to all three systems).
- 1.6.5.2 Electrical power
- The aircraft had 3 phase 115/200 Volt 400 Hz constant frequency AC and 28 Volt DC systems. One 75 Kilovolt-ampere (KVA) AC generator on each engine and a 115 KVA generator on the Auxiliary Power Unit (APU) generated the AC and, via 3 Transformer-Rectifier Units (TRU), the DC supplies. An electric power generation schematic diagram is shown at Appendix 11.
- There is a threshold core engine (N<sub>2</sub>) speed below which the AC generators go 'off line'. This is not much below the flight idle N<sub>2</sub> and the decay of N<sub>2</sub> is rapid at landing speeds. Consequently, the AC generators' output will be lost within about one second of initiating engine shutdown.
- If all four AC generators and the APU generator are unavailable, or AC busbars 1-1 and 2-4 are lost, the emergency generator is selected ON automatically. The emergency generator is hydraulically powered from the Green hydraulic system. If engines Nos 1 and 4 are shut down, Green system pressure will be lost. If this is also accompanied by loss of all AC busbars (ie no engines running) then the RAT is automatically deployed. This provides hydraulic power to the emergency generator. When this system is powered by the RAT, the emergency generator output is reduced from 5.5KVA to 3.5 KVA.
- If all AC generation is lost, including the emergency generator, the system is powered by the batteries and AC is generated by a 2.5KVA static inverter.
- 1.6.5.3 Flight control critical avionics
- The 'PRIM' (Primary) and 'SEC' (Secondary) computers are 'hard-wired' to specific control surface actuators, thus when considering the reversion modes following various electrical power system failures it is important to realise that reversion may cause operation of a particular surface to be lost, even if it has hydraulic power available. The associated hierarchy is shown in Appendix 12.
- The electrical power for the three PRIM and two SEC computers was as follows:

PRIM 1 DC ESS (Essential) or HOT BUS (Battery)

PRIM 2 DC2

PRIM 3 DC2

SEC 1 DC ESS or HOT BUS

SEC 2 DC2

- Bus DC2 is powered when any of the engine generators or the APU generator is on-line. After shutdown of all the engines with the APU not running, only PRIM 1 and SEC 1 are powered. PRIM 1 is hard-wired to the inboard aileron actuators for the Green hydraulic

supply, with a reversion path via SEC 1 using the same supply, and to the inboard elevators also for the Green supply, again with a reversion via SEC 1. The rudder also has PRIM 1 and SEC 1 operating the Green system hydraulics. SEC 1 is the backup for PRIM 3 on the left outboard aileron. Thus, following shutdown of the engines, aerodynamic control is only available while Green hydraulic power remains.

- 1.6.5.4 Description of the landing gear

- The aircraft was configured with a conventional multi-wheeled landing gear, supplemented by a centre landing gear.
- The centre landing gear was not designed to include use in gear up (or partly gear up) landings since the loads which would be generated could cause the centre landing gear to collapse, leading to structural disruption of the fuselage.
- Brakes were fitted to the main landing gear wheels only, and not to the centre landing gear wheels.

- 1.6.5.5 Description of the nosewheel steering

- The nosewheel steering was hydraulically powered from the Green system. It was controlled by the Brake and Steering Control Unit (BSCU), channels 1 and 2. During a normal landing, nosewheel steering authority is zero above 100 kt and below that speed authority is progressively increased as the aircraft decelerates until, at a low speed, full nosewheel steering is available. The system logic prevents operation unless one main landing gear and the nose landing gear oleos are compressed. In addition, Green system hydraulic pressure must be available and the nose gear doors must be closed. Nosewheel steering is unavailable if both channels of the BSCU fail; if Green hydraulic pressure is lost; if the antiskid/nosewheel steering switch is Off; or if a fault is detected within the nosewheel steering control system. If a reference wheel speed cannot be computed, antiskid braking is not available but nosewheel steering remains available. In addition, if gravity extension of the landing gear has been selected, then Green system hydraulic pressure to the landing gear circuit is isolated and therefore steering is not available. However, in each case where steering is not available the nosewheel remains free to castor. The most likely reason for the use of the gravity extension facility is considered to be the loss of Green system hydraulic pressure or contents. The Green system is the only active hydraulic system which is routed in the forward fuselage 'engine burst zone', to minimise the potential effects of an uncontained engine failure on the aircraft hydraulic systems. The Yellow hydraulic system for the cargo doors is also in this zone, but is not energised for flight.

- 1.6.5.6 Description of the braking system

- The main wheels were equipped with carbon multidisc brakes which were actuated by either of two independent braking systems. The Normal system used Green hydraulic pressure, whilst the Alternate system used the Blue hydraulic system backed up by hydraulic brake accumulators which could supply pressure for braking without antiskid protection, for at least seven brake applications. Antiskid and autobrake functions were provided, and the parking brake was also operated from the Blue system. There were four modes of operation: Normal; Alternate with antiskid; Alternate without antiskid; and Parking. Autobrake was only available in Normal mode, and Parking only available in Alternate mode.
- Braking commands come either from the brake pedals or the autobrake system. All braking functions, except certain reversions to Alternate without antiskid, and Parking, are controlled by the dual channel BSCU which obtains its electrical power from the DC1 and DC2 busbars. These, and therefore the BSCU functions, are lost in the emergency electrical configuration. For antiskid braking, the BSCU requires a computed reference speed which is derived from the 'mean' wheel speed and the aircraft speed and deceleration information obtained from the Aircraft Data Inertial Reference Units (ADIRUs). If a computed

reference speed cannot be calculated from the wheels or from aircraft speed data, then internal default reference speed information is used. Although termed the 'mean' wheel speed, it is not an arithmetic mean but is a complex summation of speeds derived from the eight main landing gear braked wheels in order to allow for various modes and failure cases.

- The system logic includes hydroplaning protection to prevent wheel locking and tyre burst during the wheel spin-up phase at touchdown on wet or icy runways. Braking is enabled once spin up is complete. This is when the 'mean' wheel speed reaches 0.98 of the computed reference speed. If the 'mean' wheel speed does not attain the required value then after 16 seconds the computed reference speed is reduced as far as is required to permit degraded antiskid braking. There is a compromise between earliest braking and allowing a reasonable time for the wheels to spin-up. During braking, if the individual wheel speeds are higher than the computed reference speed then braking remains operative but there is no anti-skid protection.
- Three brake manufacturers supply brakes for the worldwide fleet of A340 aircraft. The type of brake fitted to G-VSKY was standard across that operator's A340 fleet and had been specified by a previous customer. This type of brake had not been supplied on any other operator's A340 aircraft. This manufacturer's carbon brakes have a better gain characteristic than some others, leading to less likelihood of the braking induced vibration commonly associated with the use of carbon brakes (see section 1.16.1).
- A typical brake unit is shown at Appendix 13. The brake was mounted on a splined sleeve which extended over the length of the axle. The primary components of the brake were a torque tube, piston housing and a heat pack.
- The brake units fitted to large transport aircraft contain many braking disks in each wheel, which rotate with the wheel. Between each of these rotating disks, or 'rotors', is a non-rotating disk, or 'stator'. The complete set of rotors and stators is known as the 'heat pack', since during braking it converts the aircraft's kinetic energy into heat energy. Each stator is fixed to the torque tube which surrounds the axle, and which does not rotate. The brake unit has a piston housing which contains multiple hydraulically operated brake pistons. When pressurised these pistons apply an axial force, through a pressure plate, to the stator and rotor pack which generates the friction forces required for braking. At the opposite end of the pack from this thrust pressure plate, an end pressure plate reacts the applied thrust of the brake pistons. When the hydraulic pressure is released, the retraction mechanism in each piston assembly pulls the related piston back, allowing the wheel to turn freely. This brake had two independent sets of piston assemblies, one set for the normal braking system and the other for the alternate braking system. In a carbon/carbon brake, such as those used on this aircraft, the rotors and stators are made of a composite carbon material which provides high braking capability for a lighter weight than brake units which use steel stators and rotors.
- The thrust pressure plate, stator discs and end pressure plate had slots on their inner diameters which engaged with splines on the torque tube. The rotor discs had slots on their outer diameters which engaged with torque bars in the wheel hub. The torque tube, supported by a bush on the axle sleeve, transmits braking torque from the stator discs to the piston housing when the brakes are applied. The piston housing hub was mounted on a bush fitted on the axle sleeve. A torque rod, fixed at one end to the landing gear and connected at its other end by a torque pin to the piston housing, resisted the torque forces generated by braking loads, which would otherwise cause the torque tube, piston housing, thrust pressure plate, stators and end pressure plate to rotate. One of the functions of the torque pin assembly was to permit articulation of the brake rod/piston housing interface during take off and landing.



- The torque pin was located in a bore, fitted with two bushes, in the piston housing. The torque pin was secured by a retaining plate, which fitted against the opposite face of the piston housing, and which was bolted to an integral diaphragm at the inner end of the pin by a 1/4 inch (6.35mm) diameter steel bolt with a plain castellated nut, secured by a cotter (split) pin.
- The brakes as supplied new were complete with the torque pin assembly. The latter parts were frequently not returned with brakes for overhaul. This action inadvertently denied the brake manufacturer the opportunity to observe the in-service condition of some of the torque pins and retaining hardware. (The brake unit which was returned in exchange for the unit that was involved in this accident was returned without the old torque pin assembly parts).
- 1.6.5.7 Design of the torque rod pin assembly
- A diagram of the Increased Gross Weight (IGW) torque pin is shown at Appendix 14, page 1. The Entry into Service (EIS) pin design, as used on this aircraft, was similar to the IGW pin except for a reduced wall thickness and the use of smaller 1/4 inch diameter retaining bolt. A photograph of the EIS pin is included at Appendix 14, page 3. The use, on this aircraft, of a torque pin and single lug design at the brake torque rod and piston housing interface, as opposed to the twin lug design used on earlier Airbus aircraft types, was dictated by clearance and articulation conditions imposed on all three brake manufacturers by the A340 landing gear design. The brake and torque pin assembly was required to meet Joint Airworthiness Requirements (JAR) / Federal Aviation Requirements (FAR) certification standards and the requirements of TSO C26c (structural torque test), in addition to Airbus Industrie equipment specification 32-41-BAI-2074-LO which defined the maximum brake drag.
- The wheel and brake specification agreed between the airframe and brake manufacturers provided aircraft ground loads at each wheel (vertical and lateral) and brake stopping performance requirements from which the component requirements and loads were determined. It did not specify an axial load requirement for the torque pin assembly, which was designed to carry only the shear load induced by brake torque. The structural torque test requirements of TSO C26c did not make allowance for any axial loads in the torque pin, or for deflections of the landing gear which might give rise to such loads.
- **1.7 Meteorological information**
- The weather at the time of the emergency landing was good. The actual weather observation at 1620 hrs recorded that the surface wind was from 190°M at 13 kt, variable in direction between 150° and 210°, with a visibility 25 km, scattered cloud base 1,900 feet, broken base 7,000 feet, a temperature of °C, dew point °C, and a QNH of 991 mb. It was daylight at the time of the landing, with sunset occurring at about 1628 hrs. It began to rain at about 1625 hrs.
- **1.8 Aids to navigation**
- The Instrument Landing System for Runway 27L was used for the aircraft's final approach. There were no abnormalities associated with its operation.
- **1.9 Communications**
- Tape recordings of the transmissions between the aircraft, Heathrow Air Traffic Control and the London Air Traffic Control Centre were available for the investigation. There were no communications difficulties prior to the landing. A discrete frequency was allocated to the aircraft after the initial go-around so that uninterrupted communication with the crew was assured.
- The aircraft was also in two-way communication with the operator's Operations Department. The Chief Pilot and the A340 Fleet Manager were present to offer assistance to

the flight crew throughout the in-flight troubleshooting phase and for the period leading up to the final approach. This company operations frequency was not required to be recorded.

- **1.10 Aerodrome information**

- Runway 27L at London Heathrow Airport has a Landing Distance Available of 3,658 metres. The runway surface is of asphalt construction with a porous friction course. The threshold elevation is 77 feet amsl. The runway is 45 metres wide with load bearing shoulders 22.5 metres wide on each side of the runway over the length applicable to this landing.
- The runway is equipped with High Intensity Approach Lighting System, Threshold lights, Touchdown Zone lighting, Centreline lighting and Runway edge lighting.

- **1.11 Flight recorders**

- 1.11.1 Flight data recorder (FDR)

- The aircraft was equipped with a Loral F1000 solid state digital FDR with a recording duration of 25 hours in a 128 word per second dataframe. The FDR was replayed satisfactorily by the AAIB. A total of over 150 continuously recorded parameters and over 350 discrete parameters (events) were recorded. The FDR was part of a flight recorder system which comprised a Flight Data Interface Unit (FDIU) installed in the electronics bay, a linear accelerometer (LA) located in the centre fuselage, in addition to the FDR installed in the rear fuselage. The FDIU received data from many different aircraft systems in discrete and digital forms, in addition to the analogue output from the LA, which was first digitised and then sent to the FDIU. The FDIU then sent a standardised set of parameters to the FDR where they were stored in dataframe cycles.
- The recording on the FDR stopped 19 seconds after touchdown as the engines were shut down and electrical power was lost. The FDR system was powered from AC bus 204XP, which was fed from the No 3 generator. It did not have an independent power supply.
- The aircraft was also fitted with a Central Maintenance Computer (CMC) which was linked to the individual systems' computers which sent faults and warnings. The warnings were received by the Flight Warning Computer which then displayed them to the crew, if at the time that the warnings were generated they were not inhibited by the applicable phase of flight. The CMC also logged the faults. Each system also stored internal faults. The list of faults and warnings was available as a Post-Flight Report (PFR) from non-volatile memory within the CMC itself and, in addition as in this case, it could be transmitted in flight to the maintenance base.
- 1.11.2 Cockpit voice recorder (CVR)
- The aircraft was equipped with a Fairchild model A100 re-cycling CVR which recorded the last 30 minutes of audio information on four tracks. The recording covered the period from the approach and flypast at Heathrow until the touchdown, before the recording stopped due to the loss of electrical power. Because of the limited duration of the recording, the initial inter-crew audio communications when the problem first occurred 1 hour 16 minutes earlier were not available.
- 1.11.3 FDR data interpretation
- Figure 1 at Appendix 15 shows recorded data for the take off at Los Angeles and associated landing gear retraction. Brake pressures were recorded for each of the eight individual brake units every four seconds. The recorded data showed that the gear was selected UP 14 seconds after take off. Before the gear retraction sequence there was initially a residual pressure on each of the brake units of some 63 psi. During the retraction sequence, this increased to around 600 psi as the gear was retracted, and then gradually reduced to zero. On brake No 6, there was no increase in brake pressure, which instead reduced to zero. The landing gear indicated UP and locked 16 seconds after the associated selection.

- The CMC logged two faults associated with the disconnection of the brake torque rod as the gear was retracted into the bay. At 0509 hrs, the LGCIU sent a ' warning. This warning is triggered if the landing gear doors are not closed within 30 seconds after the gear is locked UP. This was probably caused by brake rod interference with the doors during the gear retraction sequence. There is no recording of the landing gear door position on the FDR. The CMC also logged a fault from the brake temperature sensor during gear retraction wheel braking on wheel No 6. This was probably caused by the disconnection of the brake temperature sensor as the brake spun on the wheel. At 0510 hrs the LGCIU displayed a 'L/G SYS DISAGREE' warning and logged a fault. This was not thought to be related to the rod disconnection, but is caused by a disagreement of more than 2 seconds, but less than 5 seconds, in the Centre Landing Gear uplock sensors.
- From the PFR there were no further warnings associated with the landing gear until 1504 hrs when a 'Landing Gear Not Downlocked' warning from the LGCIU was recorded in the PFR. This warning was consistent with the Left Gear not being DOWN. There was also a fault logged by the BSCU ('SERVOVALVE NORM BRAKE') which was caused by a lack of pressure being sensed at brake No 6 during the normal pre-land BSCU function test. At 1504 hrs there was also a 'L/G Gear not Uplocked' warning. This warning was triggered after the landing gear was selected UP and the gear was prevented from UP-locking or DOWN-locking due to the disconnected brake rod. These were associated with the first attempt to lower the gear normally and the subsequent retraction.
- Figure 2 at Appendix 15 shows the initial approach and the first attempt, at 1504 hrs, to lower the landing gear normally and the subsequent retraction. The aircraft descended to 900 feet Radio Altitude at an IAS of around 170 kt, before climbing to some 8,000 feet in the hold. The crew then performed a number of landing gear selections; Appendix 16 details the sequence of subsequent landing gear selections and LGCIU tests, including the first selection described above.
- Figures 3 and 4 at Appendix 15 show the final approach and touchdown, which was at an IAS of 129 kt and with a normal acceleration of 1.262g. The pitch attitude at touchdown was 7.4° and the roll attitude was 4.9°. The pitch attitude gradually decreased until the nosewheel made contact with the runway 17 seconds later. The aircraft was initially on a heading of 264°M and maintained this heading until 6 seconds after touchdown, when the aircraft began to turn gradually to the right. The aircraft remained slightly rolled to the right; however 9 seconds after touchdown the roll attitude increased to 9.8° to the right at a roll rate of 3° per second. At this point the pitch attitude was around 0° and the No 4 engine pod contacted the runway at an IAS of 124 kt.
- The High Pressure (HP) fuel shut off valves discrete recordings showed that engine No 1 was shut down one second after touchdown at an IAS of 128 kt, and engine No 4 was shut down one second later. Engine No 2 was shut down 10 seconds after touchdown at an IAS of 111 kt. Engine No 3 was shut down 6 seconds later, 3 seconds before the end of the recording. The recording ended 19 seconds after touchdown when the electrical power was lost. The final recorded IAS was 107 kt, with a roll attitude -5.6° left and a final heading of 276°M.
- Brake pedal angle was recorded by the FDR and showed that the crew applied brake pedal 10 seconds after touchdown. The brake pedal angle had increased to around the full deflection over a period of 2 seconds. It remained at around this value until the data ended 7 seconds later. There was no recorded indication of any brake pressure having been applied to any of the eight brake units. (The BSCU inhibits braking for 16 seconds in the 'Hydroplaning Mode'). Each wheel brake recorded a nominal pressure value of around 60 to 90 psi, except for wheel brake No 6 which recorded zero brake pressure. There were brake pressures indicated during the first gear down selection, when the BSCU performed a

function test and checked for pressure at the brakes. Brake No 6 showed a slight increase in brake pressure for less than eight seconds during the first gear selection, and subsequently remained at zero.

- None of the hydraulic pressure discrete recordings showed any indication of low pressure, indicating that the hydraulic systems were still pressurised. There was activity on the roll control surfaces after touchdown, similarly indicating that there was still hydraulic pressure available. The PRIM 1 discrete was switched to PRIM 2 between three and six seconds after touchdown, indicating that PRIM 1 was not operative. It was switched back to PRIM 1 four seconds later; however it was not possible to be more precise since the parameter was recorded only once every four seconds.
- **1.12 Aircraft and runway examination**
- 1.12.1 Post-incident inspection of the aircraft
- The aircraft had come to rest on Block 81 of Runway 26L (see Appendix 17). The runway marks indicated that the aircraft had been drifting right, but tracking the runway heading closely until the last 100 to 200 metres during which the nosewheel regained the centreline, but the aircraft heading had swung to the left by some 20 degrees.
- The drain mast of the No 4 engine was found in Block 85. No scrape marks were found in that area, but a police video taken during the landing showed sparks from the No 4 nacelle as it touched the runway in that block during the ground roll. At Block 83 heavy black marks had been made by the right main landing gear tyres, and these rapidly became one continuous mark together with one set of wheel rim marks as the outer tyres had burst. At the start of these marks the right main landing gear inboard door had left a narrow mark on the runway, and the No 2 engine had also left a mark on the runway. Towards the end of Block 83, large parts of the right main landing gear tyres and wheel rims were found, and at the intersection of Blocks 81 and 83 parts of the landing gear door and other major wheel parts were found. The runway surface was heavily rutted from there onwards. The No 1 engine nacelle had started to leave light contact marks on the runway by the end of the ground run. The aircraft had been well to the right of the centreline throughout the period when the ground marks were being generated.
- Inspection of the aircraft indicated that for the landing, the centre landing gear had been retracted but with the associated doors open. The centre landing gear is normally retracted after gravity extension. The nose and right main landing gears were fully down and locked. Full flap had been extended, and the RAT had deployed. All four engine fire pushbuttons on the flight deck had been operated and the associated fire bottles had been discharged.
- The left main landing gear was only slightly extended with the outboard wheels and tyres clearly visible. Closer inspection showed that the brake torque rod for the No 6 (left rear inner) brake pack was disconnected at the brake end and had swung out of alignment to become trapped in the open structure of the keel beam within the wheel bay. It was apparent that this landing gear could neither be lowered or retracted once the rod had become so trapped, and there was damage to the ancillary keel beam structure and APU duct which had occurred during the attempts to raise or lower the gear.
- The torque pin, retainer and fastening hardware for the brake end of the No 6 brake torque rod were not found. There was no evidence of damage in the associated area of the rod and it appeared that the torque pin and retainer had become separated in operation. Later, as a result of analysis of the FDR data and a detailed search at Los Angeles International Airport, the torque pin was recovered from an area off the end of Runway 24L, but the retaining hardware was not found.
- There was little damage to the wheels, brakes and tyres of the left main landing gear, restricted mainly to scuffing of the tyres. However the four tyres on the right main landing gear had burst, causing subsequent complete break-up of the associated wheels and very

severe abrasion damage to the brakes, axles and oleo. The retracted centre landing gear was undamaged. The nose gear was apparently undamaged, but was found at a large castor angle and damage to the castoring limit stops, or other damage, was suspected.

- The Nos 1, 2 and 4 nacelles had suffered some abrasion damage due to runway contact, although this was not severe except in the case of the No 2 nacelle. The No 2 pylon was also visibly distorted. The wings of the aircraft appeared undamaged, however it was later discovered that the distortion of the aft mount of the pylon had generated a minor fuel leak which was not immediately apparent due to the low fuel state at the time of landing.
- In view of the cabin crew reports after the accident, the doors were subsequently closely inspected and in the case of the 4R door, subjected to a further investigation. They were found to have been fully serviceable (section 1.16.5).
- 1.12.2 Metallurgical reports
- Following the accident, the other seven torque pins and retaining hardware on G-VSKY were subjected to specialist metallurgical examination. Shortly afterwards all the EIS standard torque pins in use on the rest of the operator's fleet were replaced by IGW torque pins (and self-locking nuts) and so all of the EIS torque pins and retention hardware removed from the fleet were also examined. Later, when the torque pin from the No 6 position had been recovered from Los Angeles, it was also examined.
- Photographic extracts from the metallurgical reports are shown at Appendix 18. From the examination of the pins and retaining hardware alone, the relevant report found no conclusive evidence to explain why the pin attaching the torque rod on the No 6 brake became detached. The report also found that:
  - a very small transgranular crack was present in one retainer;
  - a torque pin from G-VAEL was found to have a large radial crack in its end diaphragm which was considered to have been propagated by a stress corrosion mechanism (Appendix 18, plates A1 and A2);
  - in some torque pins removed from these aircraft, including G-VSKY, 'belling' of either the diaphragm in the pins or the inner end face of the associated retaining plates had resulted in a reduction in the contact area between the two faces to that locally surrounding the retaining bolts. This was initially attributed to yielding deformation induced by excess loading on the bolt, however later work conducted by the brake manufacturer indicated that the retaining bolt would fail before sufficient load could be generated to cause permanent deformation of the diaphragm. The brake manufacturer subsequently concluded that the diaphragm distortion, which was within drawing limits, had occurred as a result of the manufacturing process.
  - the torque pins and retainers were manufactured from 4340 steel which had been heat treated according to the application, and both were plated with a thin film of chromium. This thin film of chromium, although adequate for wear resistance, was not sufficient protection against corrosion;
  - the cotter pins were of a range of sizes and lengths.
- A specialist report was also prepared on the condition of the brake piston housings from the No 6 position on G-VSKY (S/N SEP91-0039) and on the No 2 position from G-VSUN (S/N APR94-0111), which had experienced a possibly related incident at Hong Kong. Examination of brake unit S/N SEP91-0039 at the manufacturer's facility showed no

obvious damage. The brake unit was subsequently functionally checked satisfactorily without leaks. Strip examination found no defects within the brake mechanism. However, one of the two bushes (the one closest to the brake torque rod) which sleeve the torque pin was found to have migrated and had adopted a slightly angled setting. It had moved 0.023 inches (0.58 mm) on one side and 0.019 inches (0.48 mm) on the other. There were no obvious marks or damage from the torque pin within the bores. Examination of the No 6 brake torque rod showed no evidence of bush migration and the overall distance across the bush flanges was within drawing limits. When the bushes were removed, it was found that although the bushes themselves were undamaged, significant distortion of the bore of the piston housing had occurred in the plane of the rod. The bore was measured and was found to be oval by 0.009 inches (0.23 mm) at the top, with the distortion extending about one third of the way into the bore. The segment of the bore which was distorted was 180° opposite to that which would be loaded with the brake fitted at the No 6 position. There was evidence of machining marks throughout showing that compression, not wear, was responsible for the dimensional change. Furthermore, the void thus created between the bush and the bore had become contaminated with debris, which was visible as a 'tide mark' on the bush and was deep within the bore. This indicated that the damage was 'old' and had occurred long before the accident flight. Some photographic extracts from the report are shown at Appendix 19.

- In view of the implications of these findings, the brake pack S/N APR94-0111 was traced and removed from service. Externally it appeared satisfactory, but upon removal of the bushes similar distortion was observed, with similar characteristics, although in this case the ovality was only about 0.002 inches (0.051 mm). The brake plate bore is normally 2.155 0.001 inches diameter (54.74 mm 0.025 mm).
- 1.12.3 Emergency lighting
- It was reported that during the landing roll the emergency lighting had illuminated only briefly after the engines had been shut down. The emergency lighting, including the floor path marking and exit signs, is illuminated automatically if the emergency exit lights selector switch is armed and the DC ESS busbar fails. In that case power is supplied by an internal rechargeable battery pack. The emergency lighting can also be selected from the Forward Attendant Panel Emergency Light Pushbutton (Purser's switch). In addition, if the 'NO SMOKING' switch on the overhead panel is selected ON, the exit signs are illuminated. The FCOM, Vol 1, states that when illuminated, the overhead and exit signs are normally supplied by the DC ESS busbar, but floor path marking is supplied by the internal batteries. The battery pack has sufficient capacity when fully charged for 12 minutes and is itself recharged from the DC ESS busbar when that is available. The FCOM indicated that selection of the 'NO SMOKING' and 'EXIT' signs from the overhead panel disabled the charging function.
- Company Standard Operating Procedures required the NO SMOKING switch to be in the AUTO position for the duration of the flight. Prior to landing, the emergency lighting was operated more than once and the NO SMOKING signs remained on from the time of completion of the Landing with Abnormal Landing Gear QRH Checklist, Preparation items. The status of the NO SMOKING signs is not recorded on the FDR. As part of the investigation, the internal batteries were recharged and the emergency lighting system then functioned normally for the required time.
- Procedural changes for the operation of the Emergency Exit Lighting have since been introduced into the FCOM Vol 3 and the QRH.
- **1.13 Medical and pathological information**
- None.
- **1.14 Fire**

- The Heathrow Airport Fire Service reported that at about 1530 hrs, they were informed of the potential aircraft landing problem. At about 1606 hrs, a call was received on the 'Crash Line' from ATC advising of 'Aircraft Accident Imminent', Runway 27L, Rendezvous Point South and the aircraft details. By 1609 hrs, all fire appliances were at their standby positions. A second confirmation message from ATC was passed at 1610 hrs, advising of the ETA of 1620 hrs and confirming that the Airport Fire Service had permission to enter the active runway after the aircraft had landed.
- At 1620 hrs, the landing time, the aircraft had been observed to come to rest in Block 81, having damaged the right main landing gear with the generation of much smoke and sparks. Friction sparks and associated smoke had also been seen from the two engine nacelles under the left wing as they came into contact with the runway. This culminated in two small fires below these engines which were quickly extinguished by the attending fire appliances. As a precaution the area around these engines was also covered in foam, along with the area around each landing gear assembly.
- The occupants evacuated the aircraft without external assistance. The attending fire crews assisted them away from the base of the slides. They were then ushered north and south of the runway to awaiting Police and Airport Operations vehicles. By 1623 hrs, it was confirmed that all of the occupants had evacuated successfully and the fire service personnel entered the aircraft by ladders to check and inspect inside the aircraft.
- As the status of the remaining landing gears was in some doubt, the assistance of one of the operator's engineering staff was sought in securing the remaining landing gears using the aircraft's gear locking pins. The Airport Fire Service maintained a presence and offered assistance and appropriate equipment throughout the recovery phase. By 1628 hrs, the airport's fire cover had been restored to the normal Category 9 status, permitting normal operations to continue using Runway 27R. The previous practice of laying down 'foam carpets' prior to the landing of aircraft with landing gear problems is no longer undertaken in the UK.
- **1.15 Survival aspects**
- 1.15.1 Crew statements
- In their statements, the cabin crew made several observations regarding the operation on the doors and slides. Door 1L had opened satisfactorily except that a push was given to activate the door assist system. However its slide did not deploy and this had to be manually inflated.
- Door 2R opened as expected, but it was necessary to manually inflate the slide.
- Door 4R was reportedly very heavy to operate and passenger assistance was requested by the attendant, who thought that the door assist system had failed. The door and rigging were later checked and no faults were found, however the door assist actuator was returned to Airbus Industrie for investigation and use in trials, the results of which are described later in this report.
- It is noteworthy that in normal operations the doors are not operated in the armed condition, and also that it is normal for the ground crew to open the doors from outside (this action automatically disarms the doors). Consequently, cabin crew have very little experience of opening the doors.
- 1.15.2 Certification requirements
- The aircraft was certificated to the requirements of JAR 25. JAR 25.809 (b) states:
  - *'Each emergency exit must be capable of being opened, when there is no fuselage deformation -*
  - *(1) With the aeroplane in the normal ground attitude and in each of the attitudes corresponding to collapse of one or more legs of the landing gear;*
  - *and*

- (2) *Within 10 seconds measured from the time when the opening means is actuated to the time when the exit is fully opened.*
- JAR 25.809 (c) states:
- *'The means of opening emergency exits must be simple and obvious and may not require exceptional effort.'*
- JAR 25.810 (a)(1)(iv) states in part, in relation to door requirements:
- *'It must have the capability, in 25-knot winds directed from the most critical angle, to deploy .....'*
- 1.15.3 Certification demonstration of compliance
- On the Airbus A300 series aircraft, demonstration of compliance with the certification requirements was by rig test at appropriate pitch and roll angles, with a 25 kt side wind simulated. Because of design similarities, demonstration of compliance for the Airbus A330 and A340 series was conducted by analysis, since all the factors such as door and slide mass, roll and pitch angles were considered to be more favourable than those for the original design.
- **1.16 Tests and research**
- 1.16.1 Brake loads
- The brakes fitted to G-VSKY used carbon rotors and carbon stators as used on many modern aircraft types. Such materials have improved braking performance, but inherently have less than ideal characteristics because as hydraulic pressure is increased the resulting brake torque is very dependent upon brake temperature and wheel speed. This 'gain' characteristic curve typically results in a sharp rise in brake torque with brake temperature, so that when first applied the braking effort required is high, but as the brakes heat up they suddenly become much more effective. In some cases on other designs this has given rise to brake 'grabbing' and severe vibration. In addition if the grabbing of each brake unit is out of phase with its partner, large deflections of the landing gear can result.
- The ABS Ltd manufactured brakes fitted to G-VSKY used a particular type of carbon/carbon material which had a less sensitive characteristic 'gain' with temperature. Because such materials were used, the possibility of severe and unanticipated loadings arising from the dynamic behaviour of the brakes was minimised, and this had not been a problem generally on the Airbus A340. As a result, attention was focused on other possible modes of failure of the torque pin retention assembly.
- Maximum brake pressure available at the wheels is 175 bar (2,500 psi) at which the maximum drag specified for the brake is 20584 dN. The highest structural torques occur at low speed where the drag factor may be as high as 0.8. Turns can give rise to axial loads in the torque rod pins.
- Technical Standard Order (TSO) C26c defines the brake structural torque test requirements. The structural torque test applies a factor, in this case 1.44, to the maximum vertical wheel load and the resultant brake drag is applied as a steady static load for three seconds. The test requirement is that the brake should not fail within the three second period, but some permanent deformation would not constitute failure. As originally certified, it was demonstrated by test that the brake had met these requirements.
- 1.16.2 Axial loads in torque rod pin and bolt
- As part of this investigation a series of tests were undertaken to examine both the structural strength of the brake and the axial loads generated in the torque pin. Initially strain gauges were fitted to the torque pin, but the test results were unsatisfactory largely because of difficulty in distinguishing between axial and torque loads, and so further tests were conducted using load cells fitted to the retaining bolts of the torque pins at the No 1 and No 6 wheel brake positions. It was observed that a significant static load existed in the bolt due to torque tightening. The installation instructions contained in the Aircraft Maintenance



Manual (AMM) called for a 'dry' torque of 0.57 to 0.79 m.daN (5.7 to 7.9 Nm) to be applied to the nut during tightening of the bolt and the torque pin retaining assembly, ie no oil or grease was to be used when applying the specified torque. By using a generally accepted formula for calculating bolt tensile load, this should have resulted in a tensile load in the bolt of between 4.5 and 6.2 kN, however if these items were assembled 'wet', ie with oil or grease present, the same torque range could generate a much larger tensile load. In addition, re-use of the fasteners can affect the resulting pre-load. During testing, after assembling the items 'dry', the load cell instrumentation recorded 12.4 kN, and this may have indicated that there was some oil or grease present on the fasteners. It would not be normal practice to degrease such items before torquing. The bolt, which was the limiting strength component in the assembly, was a 1/4 inch diameter Unified (UNF) bolt (6.35mm diameter; the brakes were of US manufacture and specified in Imperial units throughout) manufactured in a corrosion resistant steel with a minimum ultimate tensile strength (UTS) of 125,000lb/in<sup>2</sup> (861.84 MPa) giving the bolt a rated tension capacity of 4,080 lb (18.15 kN).

- With the engines shut down, 175 bar of brake pressure was applied. As expected, no additional loads in the load cells were measured. However with the engines running at ground idle and maintaining 175 bar brake pressure, some small loads were observed. Braking tests were then carried out but these did not produce sufficient torque to determine effects on the axial load. All these tests were conducted with the torque pin assembly so installed as to have axial free play when static. Additional loads were measured by the load cell due to nosewheel steering angles, the magnitude of these loads were slightly above the installation load. Graphs of the load due to steering effects as measured, including the static load, and of the theoretically calculated load due to braking torque, are shown at Appendix 20. In addition, low speed taxi trials were conducted which demonstrated that an unsecured torque pin would rapidly migrate during turns.
- If the torque pin and retainer are correctly assembled to the brake and torque rod, a clearance should exist to permit limited end float of the torque pin assembly. Also, when correctly assembled the torque pin diaphragm is loaded compressively against the face of its retainer. In this case the torque induced preload in the bolt and the applied tensile load are not additive. However if the assembly is such that the required end float does not exist, a gap may be developed between the torque pin diaphragm and its retainer. Under this condition, any externally applied tensile load is additive to the bolt preload, and the torque pin diaphragm and the retainer experience 'belling' of their diaphragms. It was found, partly by testing and partly by analysis that, under peak torque (limit) conditions the axial load generated in the bolt could reach some 11 to 15 kN. Although this load, which represented the most severe brake drag load attainable, was less than the theoretical minimum UTS of the bolt (18.15 kN), if a gap existed between the torque pin diaphragm and its retainer the minimum bolt preload would add a further 4.52 kN which could then be sufficient to cause the bolt to suffer tensile failure. During testing of typical bolts, the actual load required to fail the bolt was found to be 25.21 kN.
- The airframe manufacturer also advised that the brake/brake rod interface experiences relative motion, transmitted through the torque pin, was due to articulation of the trailing bogie landing gear design during take off and landing, and due to gear deflections during braking. Axial loads could therefore be developed in the torque pin by ground manoeuvres, while torsional loads in the torque pin assembly could be developed by relative rotational motion in combination with axial loads.
- 1.16.3 Loads in the brake
- The structural torque test requirements for the brake assembly were demonstrated for FAA certification purposes by the brake manufacturer. The associated Qualification Test Plan was reviewed by the brake manufacturer, the airframe manufacturer and the certifying

authority, and subsequently accepted by the certification authority. The certification test was conducted, as is customary, with the brake assembly fitted to a solid axle which had external dimensions that were representative of that fitted to the aircraft. The certification structural torque test of the brake assembly was completed satisfactorily, without component failure. However, this solid axle test could not correctly reproduce the associated deflections which the real axle would experience in service and did not therefore generate realistic axial loads in the torque pin and its retaining assembly.

- Following this accident and the finding of permanent deformation of the piston housing bore beneath the torque pin bushes on two brakes, brake tests were carried out in accordance with the original certification requirements. This was also done in order to certificate the redesigned torque pin and retention device. For these tests, the axle deflections were taken into account and the tests were conducted in increments to approach the maximum drag requirement, and then the structural torque load. The loads were then incrementally reduced through a further series of tests. In order to assess the loading at which permanent deformation of the torque pin bore beneath the bushes began to occur, it was necessary to remove the bushes after each test increment, re-measure the bore and re-fit the bushes in order to continue with the next load increment. This caused considerable delay in the testing programme.
- However the results of this test programme showed that permanent deformation of the torque pin bore occurred at a drag factor as low as 0.6, due to the deflections arising within the axle, brake, torque pin and brake torque rod. These deflections placed the torque pin, the axis of which is nominally normal to the applied forces, at a greater angle to the applied forces than previously thought, thus generating larger loads than originally expected in both the torque pin assembly and the piston housing. It was found that permanent deformation of the torque pin bore, measured at 0.25 inches (6.35 mm) into the bore, was 0.0055 inches (0.14 mm) at the maximum drag load (coefficient = 0.8, IGW maximum vertical wheel load) and 0.055 inches (1.4 mm) at the structural torque load to the IGW conditions. In these cases the distortion of the bore progressively reduced with distance away from the bore/brake torque rod interface, in a manner similar to that seen on the two brakes examined.
- The foregoing discussion considered only static effects, however the magnitude of the applied loads were considered the maximum that could be achieved in a dynamic case. The structural torque was considered to be an ultimate case which would not be exceeded by a dynamic case. It was not thought by the airframe manufacturer that the use of carbon brakes had, in itself, been a particularly significant factor in brake loads.
- 1.16.4 Hydraulic supplies during the ground roll
- The Emergency Checklist called for the engine fire push buttons to be operated in a gear up landing. This action was required to minimise the risk of fire and of fan blade release, since even at idle thrust there is a significant risk of engine break-up due to casing distortion. Shutting down the engines by using the fire push buttons causes the engine driven hydraulic supplies to be immediately isolated by closure of the hydraulic fire valves. If the engines are shut down by operation of the engine master switches, hydraulic flow and pressure is generated by each engine driven hydraulic pump until  $N_2$  decays below a critical speed. Some flight tests were conducted by Airbus Industrie using an A340-300 (MSN 001) to evaluate hydraulic supply decay in this situation. Engine No 2 was shut down during the flare; on the ground with high hydraulic demand; and on the ground without hydraulic demand. In each case the decay in  $N_2$  with time was similar, eliminating aircraft speed and hydraulic demand as significant factors in  $N_2$  decay. It was observed that the hydraulic flow available was dependent upon  $N_2$  and therefore on time after engine shutdown, however pressure was a function of hydraulic demand as well as time. In order to keep Green system

demand consistent with RAT performance, RAT invoked flow demand limitations exist. These are activated when the RAT is deployed and either Blue or Yellow hydraulic pressures are low, or No 1 and No 4 engines are shut down. It was found that, without any limitations being imposed by the RAT, and with maximum possible demand, the pressure dissipated to the failure threshold in 15 seconds, otherwise pressure could be maintained for up to one minute. If all four engines were shut down, the RAT deployed and its limitations therefore applied. This increased the time available at maximum controls activity to 30 seconds (neglecting the hydraulic output from the RAT itself). The Airbus Industrie diagrams of flow demand and systems capability are shown at Appendix 10. A minimum approach speed limitation of 140 kt applies to prevent RAT propeller stall.

- 1.16.5 Door opening tests
- In order to further investigate the problem with door 4R, the door manufacturer prepared a test rig ( Appendix 21, page 1 ) using a production door acceptance gauge which was suitably modified to apply simulated wind loads, slide loads and forces arising from the door mass. The door weight, 124 kg, becomes significant when the aircraft is not level. To represent the slide, a large mass was used which was attached to the door in the same manner as a slide, so that during door opening the slide release mechanism was operated and the mass released to simulate, reasonably closely, the behaviour of a slide. A transducer, measuring door hinge arm angle and another measuring Y-axis load (wind load rectangular to the door) on the door were fitted and connected to a computer which plotted door opening and load against time.
- In addition, the door assist actuator from door 4R was removed from G-VSKY and used in the test demonstration. These actuators are pneumatically operated from charged gas cylinders. On opening an armed door, the door assist mechanism is operated by the door mechanism. This causes an aluminium diaphragm in the assist mechanism to be pierced by a hollow needle, releasing the gas charge into the cylinder. The cylinder then receives a regulated gas flow at a pressure high enough to open the door against its weight, wind forces and slide loads. The diaphragm can easily be replaced and the cylinder recharged.
- A number of tests were conducted to cover two load cases, ie that required for certification and the case pertaining to this accident (Appendix 21, page 2). For the first case, maximum adverse angles and a 25 kt wind were simulated; in the second case the calculated angle was lower and zero wind was used. Plots for both test cases were produced and these are shown at Appendix 21, pages 3 and 4.
- In the most adverse case the door opened fully in about 8 seconds, within the required time, and completely unassisted. However, it was observed that the door hinge arm did not operate at a uniform angular rate. Initially it was quite fast but rapidly slowed and, between about 20 and 30 degrees, appeared to stop. This was attributed to the release of the slide which occurred at between 20 and 46.5 degrees, and which caused a delay while the pressure in the cylinder rose. Once this effect had taken place, the door continued to open. In addition, the relationship between the door hinge arm angle and the door opening was non-linear, so that at the time the system slowed down, the door was only just opening. It was observed that by pushing on the door in this condition it was possible to prevent the gas pressure from building up sufficiently to assist the door, giving the impression of a failure of the assist system, even though the door system was fully capable of meeting the certification requirements. In the conditions pertaining to this accident, an 8 to 10 kt headwind existed and so no wind component was used for the tests. It was found that the door repeatedly opened rapidly without assistance.
- With these test results completed, a further check was conducted on G-VSKY. The cabin attendant who had operated door 4R was present for the check. The door was opened and set to a position where the hinge arm was rotated through 20°, and again at 30°. With the

door trim in place, the apparent opening of the door was minimal. The cabin attendant confirmed that the positions were broadly similar to the position at which the door had 'hung' during the evacuation. A senior A340/B747 cabin crew member pointed out that on the Boeing 747 and A340 fleets the training was to manually push the doors at the first sign of any difficulty in opening, as advised in both manufacturer's cabin crew manuals. The operator's Cabin Safety Officer stated that the A340 training simulator door opened at a steady rate and could be re-opened repeatedly without maintenance, unlike the real door which required replacement of the gas cylinder after each emergency opening.

- During the rig tests, using a real door, it was necessary to fit a replacement gas cylinder to the door for each test. While doing this it was observed that the sealing diaphragm was pierced to an extent which might allow a small portion of the diaphragm to be released and possibly block the internal passageways. To assess this, the manufacturer conducted several tests and reported to Airbus Industrie that there was no risk of blocking or mis-operating during one emergency opening. The Component Maintenance Manual also specifically called for a check for any released debris during replacement of the diaphragm.
- 1.16.6 Slide investigation reports
- The eight slides were returned to the manufacturer for inspection, refurbishment and repacking. The manufacturer's report described the incoming condition of each slide and the work carried out. No significant defects, other than those arising from the deployment and use of the slides, were reported. The reason for the need to manually inflate slides L1 and R2 was not established.
- **1.17 Organisational and management information**
- 1.17.1 Rescue and Fire Fighting Services requirements
- The level of crash, Rescue and Fire Fighting (RFF) facilities normally available at an aerodrome are expressed as a category. These categories, expressed on a scale of 1 to 9, take into account the availability of extinguishing agents, equipment to deliver the agents and personnel to manage the equipment. Civil Aviation Publication (CAP) number 168 details these requirements for airports in the UK. The requirement for facilities increases with the size (in terms of fuselage length and width) of aircraft intending to use an airport.
- In this case, for the Airbus A340, which has a fuselage length of between 61 metres and 76 metres, with a fuselage width of less than 7 metres, the requirement is for CAA Category 9 equipment to be available at the airport of operation.
- Exceptionally, operations may be conducted into airports having one category less than the normal specification, provided that agreement exists with the particular airport concerned and certain conditions as to overall numbers of movements apply.
- When facilities are reduced, for whatever reason, the commander should take into account all relevant operational considerations before deciding to continue or divert the aircraft, and ensure that the intended landing airfield has the necessary category cover. Details of these requirements are contained in the operator's Operations Manual General.
- Government owned airfields in the UK operate to a Royal Air Force military RFF standard. There is no direct comparison between RFF standards at military airfields and those at UK civil airports. The UK Aeronautical Information Publication (AIP) contains a table of approximate comparisons between ICAO/CAA standards and the RAF equivalents. This is intended for use by civilian pilots wishing to use government airfield facilities and is shown in Appendix 22.
- It should be noted that the highest RAF category available (Category 7) is broadly equivalent to CAA Category 6. There is no RAF equivalent category to the CAA Category 9 which is required for Airbus A340 operations.

- The airline Operations Manual General did not contain any table of comparison between CAA and RAF RFF categories. However, such a table did exist in the operator's proprietary navigation chart library, carried onboard each aircraft.
- 1.17.2 Company Operations aspects
- The operator's Operations Department near London Gatwick Airport was informed of the problem with the aircraft's landing gear at about 1505 hrs. A VHF radio link was established on the normal company operations frequency. At that stage, the aircraft was established in the Bovingdon holding pattern with about 10,350 kg of fuel on board, which was sufficient for a holding endurance of about 2 hours.
- After discussions within the Operations Department, it was agreed at about 1520 hrs that the operator would contact Royal Air Force Manston in order to ascertain whether the airfield could accept the aircraft, if necessary, for an emergency landing with the landing gear unsafe condition. The commander was advised of this planning.
- This readiness request was made to Manston ATC just before 1540 hrs and it was confirmed that the airfield was ready to accept the aircraft, being up to the maximum available (Royal Air Force) RFF Category 7, at about 1600 hrs.
- **1.18 Additional information**
- 1.18.1 Air Traffic Control aspects
- The aircraft initially carried out a go-around at about 1504 hrs and was given radar vectoring into the holding pattern at Bovingdon while the flight crew attempted to resolve their landing gear problem.
- At about 1530 hrs, the LATCC General Supervisor (GS) Heathrow telephoned the Heathrow ATC Watch Manager (WM) to ascertain whether Heathrow Airport Ltd would accept the aircraft in the event of an emergency landing. When contacted by the WM, the initial reaction of the Heathrow Operations Duty Manager (ODM) was to suggest that the aircraft be diverted elsewhere, but stated that he would discuss the matter with the operator.
- The possibility of offering Runway 23 for landing was considered as the surface wind was from the south, but some aircraft were parked on the 'W' stands, to the south side of Runway 27L, which affected its short term availability.
- At about 1540 hrs, the ODM, having spoken to the operator's management, indicated that a flypast of the Control Tower was being planned for a visual inspection. It was also indicated that Manston had agreed to accept the aircraft on diversion if necessary. At this stage, the aircraft's estimated endurance was just over one hour.
- The flypast was carried out at about 1601 hrs and the visual status of the landing gear was determined. The aircraft then went to the north-east in order to conduct manoeuvring in a further attempt to extend the left main landing gear.
- Whilst the aircraft was positioning for the flypast, a telephone conversation took place between the Heathrow WM and the operator's A340 Fleet Manager. During this discussion, it was indicated that the aircraft's fuel state now precluded a diversion to Manston. It was proposed that, after the flypast, a touch-and-go landing would be performed at Heathrow to try to 'bump' the left landing gear down. The aircraft would then position around the circuit for a final landing at Heathrow, and it was suggested that Runway 27L would be the most appropriate runway given the nature of the damage and the crosswind component.
- In the event, the commander declined to perform the second flypast or the touch-and-go landing. Instead, some manoeuvring was carried out to the north-east of Heathrow, after which the aircraft was positioned for the final landing.
- At 1608 hrs, a Mayday was declared prior to the commencement of the final approach. The 'Aircraft Accident Imminent' status had been declared and the Police were requested to ensure that the Inner, Outer and Southern taxiways were cleared of traffic and that the aircraft on the 'X' parking stands were cleared of personnel. All work adjacent to the

runways was stopped and all departures were suspended. Aircraft that had taxied towards Runway 27L for departure were routed clear of the area.

- After the aircraft had touched down in Block 86 on Runway 27L at 1620 hrs and come to rest in Block 81, the status was upgraded to 'Aircraft Accident' and a Notice to Airmen (NOTAM) was issued, advising that Runway 27L was closed until further notice. An appropriate message was also broadcast on the Automatic Terminal Information Service (ATIS) to advise other aircraft of the situation.
- There is a Supplementary Instruction No 2 of 1993 to the Manual of Air Traffic Services, Part 1, which suggests that it is desirable that an aircraft in an emergency should not be routed over densely populated areas, but the most expeditious routing is appropriate if other routes would jeopardise the safety of the aircraft. However it was not considered necessary to implement this in this case as there was no apparent damage to the aircraft structure which could have led to the detachment of parts from the aircraft.
- An inbound flow control rate of 24 aircraft per hour was agreed for arrivals using single runway operation on Runway 27R. Departures resumed as soon as the airport had been restored to Fire Category 9 status at 1628 hrs, with exclusive use for landings from 1640 hrs until 1700 hrs. From that time, it was agreed to provide arriving traffic with 6 nm spacing in order to allow departures to be interspersed with landing traffic.
- During the overnight aircraft recovery period, the agreed traffic flow rates were set at 16 per hour for arrivals and the same number for expected departures.
- The achieved movement rate between 1700 hrs and 2000 hrs was 52/53 movements per hour using the single Runway 27R. A movement is defined as a take off or a landing. Runway 27L reopened for use on 6 November at 1200 hrs.
- The airport handled over 440,000 movements during 1997. The majority of these occurred between 0600 hrs and 2300 hrs each day. The average daily traffic was therefore about 1,210 movements per day, or 71 movements per hour when averaged over the 17 hour period. At peak times, the typical movement rate can increase to between 80 and 84 movements per hour, dependant upon weather conditions and traffic mix, with both parallel runways operational.
- During periods of single runway operation, which rarely exceed a one hour duration during 'daytime' operations, the typically achieved movement rate is around 54 movements per hour.
- 1.18.2 Preparations at Manston Airport
- Manston, Kent International Airport, is owned by the Ministry of Defence and has an Air Traffic Control service operated by military personnel. It is available to civil aircraft by prior permission.
- It has a single Runway 10/28, length 2,752 metres, width 61 metres. There is no Instrument Landing System installed, but a Precision Approach Radar facility is available for approaches to either runway direction.
- The weather at the time was good.
- A report from the Senior Air Traffic Control Officer (SATCO) at Manston indicated that they had been informed of the possible diversion requirement for G-VSKY by the operator at about 1540 hrs. The airfield was at its normal (military) RFF Category 4 at that time and it was requested that this be raised to Category 7, the maximum available.
- At about 1545 hrs, the operator telephoned again to update Manston on the situation and indicated that G-VSKY would divert to Manston if the problems persisted after the flypast had been completed at Heathrow. It was advised that Manston would be available at Category 7.

- Medical and administrative facilities at the airfield were advised of the potential to activate the Station Disaster Plan and the airfield was ready at Category 7 status at 1552 hrs. This was confirmed to the operator at about 1600 hrs.
- By 1605 hrs, Manston was informed that because of the aircraft's fuel status, it would not be diverting to land at Manston. However the airfield remained at Category 7 status until 1636 hrs, in order to remain prepared to accept any other possible Heathrow diversion traffic. In the event, this facility was not required.
- The SATCO commented that the RFF category had been raised very quickly from Category 4 to 7. Manston was the home for the Ministry of Defence and the Royal Air Force Fire Schools, and their services and equipment were available at short notice. The successful part-activation of the Station Disaster Plan demonstrated that Manston Airport was capable of generating the necessary assets and infrastructure that would have been required to deal with such an incident.
- 1.18.3 Heathrow Operations
- On being advised of the potential problem with the aircraft's landing gear, the ODM at Heathrow contacted the airline's Operations Department. At that time, it was the airline's intention that if the problem could not be resolved, the aircraft would divert to land at Manston and such arrangements were being put in hand. Heathrow maintains a Civil RFF Category 9 at all times for the regular frequent operation of the largest commercial aircraft.
- At about 1530 hrs, the ODM confirmed to the airline that it was Heathrow Airport Ltd's preference that the aircraft divert to land elsewhere if the problem persisted. At about 1600 hrs, the ODM was present in the Control Tower Visual Control Room to observe the aircraft flypast. When the commander declared his intention to land at Heathrow and declared the 'Mayday', the ODM consulted with the ATC
- Watch Supervisor and they agreed to use Runway 27L for the landing so that any potential turn towards the retracted landing gear on landing would take the aircraft away from the central area and terminal buildings.
- In order to offer assistance in lining the aircraft up with the landing runway, it was decided to leave the runway lighting on until the aircraft touched down. In the event, several runway edge light fittings were damaged and the associated power supply was isolated after the landing.
- There is an agreement with Heathrow ATC and LATCC that the ODM may request the following message to be passed to an inbound aircraft with a technical problem that has potential to block a runway:
- 'This is a message for the captain of (aircraft callsign) from Heathrow Airport Limited. Your technical problem could cause a runway to be blocked at Heathrow; you are asked to consider an alternative, less busy, airfield rather than risk major inconvenience to other operators.' This message is not intended to be passed if the aircraft has declared an Emergency (Mayday or Pan), has a fuel shortage, or when a diversion would increase any risk to the aircraft.
- This message was not initiated by the ODM on this occasion since the airline operator had stated from the outset that the aircraft would divert to Manston if the landing gear problem persisted. By the time the final decision had been made to land at Heathrow, the commander had declared a 'Mayday' and the message is specifically excluded from being broadcast under such circumstances.
- 1.18.4 Degradation of braking capability
- Brake pressure was recorded on the FDR. The FDR went off-line during the landing roll and engine shutdown sequence. Since the Green, Blue and Yellow hydraulic systems were still pressurised at the time that the FDR went off-line, the exact sequence of events by which the braking system degraded could not be determined from the flight data. However

the system lost antiskid braking, either because of the sequential loss of Green and Blue systems, or because of the BSCU losing valid reference speed. This aspect has been addressed by the manufacturer in an amendment to the QRH requiring antiskid to be selected OFF and advising the crew to use a maximum of 1,000 psi applied brake pressure. This provides braking without antiskid throughout the landing, with no changes apparent to the crew as the system degrades.

- A study was carried out by the manufacturer which showed that with the crew limiting brake pressure to 1,000 psi with one main landing gear retracted, and using the best available assumptions, the revised procedure would result in an increase in the landing distance required of 11.5%, which is within the normal landing performance allowances used in the determination of the suitability of a particular runway for landing.
- 1.18.5 Directional control and stability
- In response to AAIB requests, Airbus Industrie carried out a study to determine the degree to which the aircraft would be directionally controllable during the landing roll. This study was particularly difficult because of the interaction of aerodynamic and mechanical forces, indeterminate loads on each landing gear and nacelle, and variables in the use of brakes and steering. The study assumed that no steering was available and that the nosewheel was free to castor throughout the ground roll. It also assumed use of the brakes in accordance with the revised procedures, which should be the case in any future similar incident. In addition it assumed a value for the coefficient of friction of the nacelles on a paved surface of approximately 0.2 to 0.3. Finally, the effects of crosswinds up to 25 kt from each side of the aircraft were considered.
- The study concluded that the aircraft is controllable initially due to aerodynamic forces. After the nacelles contact the runway, the significant forces are mechanical. In zero crosswind conditions directional control is, in most cases, maintained. For crosswind conditions, the speed at which a deviation of 15 metres from the runway centreline occurred was taken as the limit of controllability. For a 25 kt crosswind which was from the side with the main landing gear normally extended, the aircraft would come to rest before reaching 15 metres deviation in every case. If the 25 kt crosswind were from the side with the nacelles on the runway, then the 15 metres deviation would be attained while the aircraft was still moving at significant speed, the exact value depending on the weight, coefficient of friction of each nacelle, and load distribution. In a worst case, this speed could be in excess of 50 kt. The associated plots are included at Appendix 23, and clearly show the benefits of a favouring crosswind.
- Airbus Industrie also conducted a review to determine the feasibility of retaining nosewheel steering following the selection of landing gear free-fall. This would require restoring operation of the Green system which would then incur the risk of interfering with the 'down and locked' condition of the landing gear, in addition to the risk of loss of the Green system contents; this option was therefore rejected. Without hydraulic power there is no point in retaining BSCU control of the steering, therefore no changes are now planned to the BSCU architecture as a result of this incident. However a modified BSCU will be introduced which will provide availability of the nosewheel steering when antiskid is selected 'OFF'. This will be fitted to -500 and -600 series aircraft and will be compatible and available for other A340 variants.
- 1.18.6 Previous incidents
- Airbus Industrie records indicated 8 cases of discrepancies in the security of the torque pins on A300 aircraft, and 2 cases on A310 aircraft, all with Messier brakes. They were all attributed to misassembly, and in no case was the torque pin or retainer actually missing. The Messier brake is of a different design to the ABS brake. A related caution was added in the Aircraft Maintenance Manuals and a modification was later introduced for these types.



- The first reported incident involving an Airbus A340 fitted with ABS brakes occurred on 2 April 1997 when another of the operator's A340 aircraft, registration G-VSUN, MSN 114, was involved in an incident at Hong Kong. During a normal landing roll, the brake torque rod at the No 2 position became detached at the brake end and dragged on the runway, causing considerable abrasion damage to the rod; there was also damage to the brake unit because it had then been free to rotate. Neither the associated pin, retainer, nor any of the fasteners were found. This was the first incident of this type to be reported to the brake manufacturer. The aircraft had completed 4,179 hours and 595 landings since new. The last maintenance input on the brake was 399 hours earlier, but the torque pin had not been disturbed at that time. As no maintenance had been carried out in that area since delivery, it was concluded by the manufacturer at that time that the cotter pin had not been correctly fitted during production. A related All Operators Telex was issued by the aircraft manufacturer, although at that time this was the only operator with ABS manufactured brakes.
- A fleet check discovered one case where the cotter pin was missing; the affected aircraft was, coincidentally, G-VSKY and the discrepancy was found at the No 6 wheel position, ie the same position where the torque rod later separated in this accident. However this was not the same brake unit as that involved in this accident which was installed in May 1997. There appears no evidence to link that missing cotter pin to this accident, and it was by no means certain that the incident at Hong Kong was caused by a missing cotter pin. The brake unit from G-VSUN had been returned to service since it had been declared serviceable after inspection. After the accident to G-VSKY, that brake unit was located and removed from service, and the bushes removed to facilitate inspection of the bore. Some old damage was found within the bore, as indicated in section 1.12.2. This damage was similar to that found on the subject brake unit from G-VSKY, although less severe.
- AAIB Bulletin 2/99 contained reports on two related occurrences, one to an Airbus A300 B4 and the other to a Boeing 767. The A300 incident occurred on 17 July 1997. The aircraft was fitted with wide track bogies and Messier-Bugatti brakes, which secured the brake torque rod with a torque pin and collar, through which a bolt was fitted transversely. During take off, the No 1 brake anti-torque rod became detached and was found on the runway. The brake unit rotated, damaging hydraulic lines and electrical wiring. The landing was uneventful except for the reduced braking capability. The event was attributed to failure of the collar bolt in shear, due to excessive axial loading of the pin assembly. There was evidence of large elastic deformation of the entire assembly which caused the bolt to fail and also allowed the rod to slide off the torque pin, which it cannot normally accomplish. Inspection of the other brakes found fretting corrosion damage on the shanks and, at the No 2 brake position, plastic deformation of the bolt in shear at the collar. The report cited faulty antiskid operation or other brake defects as possible factors which had initiated the problem.
- The Boeing 767 incident occurred on 1 May 1998. During landing the No 8 brake fractured at the reaction rod attachment, releasing the rod. The bore of the brake for the rod attachment was severely ovalised. A history of problems with carbon/carbon brakes on Boeing 767 aircraft was cited in that report, and the problem was attributed to a highly energetic vibration mode between adjacent brakes, initiated by the characteristics of the brake material. The problem was being addressed by the introduction of a new carbon material with better 'gain' characteristics.
- 1.18.7 Corrective actions
- A summarised chronology of the safety action taken following this accident is given below:

6 Nov 97

Airbus Industrie issued Operator's Information Telex advising of the accident.

Visual inspection for security prior to each departure imposed.

8 Nov 97 Initial laboratory examination of the remaining torque pins and attachment hardware accomplished.

French DGAC draft Airworthiness Directive received by manufacturer and operator. This was not published in this form.

Special Check issued by operator for Non-Destructive Inspection of standard weight (257 tonnes) fleet. Replacement of nut, bolt and cotter pin with new items required by the same check. The nuts, which had been normal castellated nuts, were replaced with self-locking castellated nuts; the other fastener hardware was to the previous specification.

10 Nov 97 DGAC AD action by Telex.

Special Check scope increase to include IGW (262 tonne) fleet.

11 Nov 97 SB 5012475-32-A1 issued to change castellated nut to a self locking type. SB 5012220-32-A5 introduced IGW pin (Appendix 14, page 3, shows photograph of IGW torque pin) with self locking nut to standard weight fleet. Although interchangeable, the IGW parts consisted of a stronger torque pin and retainer, and larger diameter fastening hardware.

75 cycle life limit imposed on standard torque pins. Later this was increased to 150 cycles, and then to 250 cycles.

13 Nov 97 A washer was introduced between the torque pin and retainer to ensure the installed assembly had axial clearance. This could be necessary even with the bushes correctly seated. The brake manufacturer advised that the probability of loss of clearance occurring depended on an adverse tolerance build up and was calculated to affect only one assembly per thousand. The installation of the washer precludes any possibility of such loss of clearance.

Notice To Operators issued by Airbus Industrie authorising use of IGW torque pins and self-locking nuts on standard weight aircraft, and use of self locking nuts on IGW aircraft.

17 Nov 97 Content of current QRH 'Landing with Abnormal Landing Gear' procedure queried by AAIB to Airbus Industrie.

- 19 Nov 97 G-VSKY torque pin recovered intact from Los Angeles.
- 12 Dec 97 A secondary restraint system was introduced by SB A340-32-4115 to provide a means of preventing a brake torque rod from contacting the aircraft structure in the event of loss of its torque pin. The design consisted of a steel cable attached with Jubilee clips between adjacent rod ends. The fleet was modified between 15 and 24 December 1997.
- 26 Jan 98 Proposed changes to QRH 'Landing with Abnormal Landing Gear' procedure presented by Airbus Industrie to the AAIB and the operator.
- 6 Feb 98 SB A340-32-4116 issued. Following the accident, the torque pin assembly was redesigned by the brake manufacturer to allow for the previously unknown and unexpected higher loading of the brake torque pin retaining assembly. Analysis of a theoretical model incorporating a significant axial load indicated that the redesigned bolt and collar retention device had large fatigue and ultimate reserve factors. The brake torque rod attachment redesign introduced a longertorque pin located by a collar locked externally by a bolt, self-locking nut and cotter pin ( Appendix 14, pages 2 and 3). This was fitted across the fleet by 24 February 1998 as terminating action.
- 12 Feb 98 AOT 32-18 required the re-orientation of the torque pin which attaches the outboard brake torque rod to the main strut such that it cannot fall out if the pin attachment collar is released. This was also covered by the issue of SB A340-32-4120 on 5 June 1998.
- 7 Mar 98 Temporary Revision 95-1 issued to introduce amended QRH 'Landing with Abnormal Landing Gear' procedure. Amongst other important procedural changes, this called for Anti-Skid and Nosewheel Steering Switch to be placed OFF prior to landing with one main landing gear abnormal in order to initiate alternate braking. The sequence and timing of the engine shut downs was also amended.
- 20 Oct 98 A further modification to replace the cable with a restraint of better design was introduced retrospectively across the fleet, irrespective of the type of brake installed. A diagram of the final design is shown at Appendix 24. This

modification was also introduced on to all new build A340s and scheduled to replace the earlier restraint on all A340s by 31 July 2000.

- 1.18.8 Service assessment of redesigned torque pins and retainers
- Following the entry into service of the redesigned torque pin and collar retention device, some further metallurgical work was commissioned by this operator. The new design standard had a higher maximum allowable strength than the original design, ie 21,000 lb (93.41 kN) for the new design compared with 4,080 lb (18.15 kN) for the EIS standard, and was a very similar configuration to other types in service.
- After a period in service, the retaining collar bolts were found to exhibit marks on their shanks which the associated metallurgical report attributed to slight plastic deformation arising from axial loads in the torque pin. The manufacturer's laboratory report concluded that the markings were 'typical of the application and posed no detrimental effect to the integrity of the brake assembly'. The slight plastic deformation evident on these bolts did indicate, however, that local stresses in the order of the maximum allowable had been applied during a period of apparently normal aircraft operation.
- 1.18.9 Recovery of the aircraft
- At the time this accident occurred, suitable recovery jacks were not available commercially and normal maintenance jacks were too high when retracted to be installed under the wing when it was resting on the nacelles. Furthermore, maintenance jacks could not accommodate the side loads resulting from the lateral displacement of the jacking pad during lifting operations. For these reasons the Aircraft Recovery Manual (ARM) prescribed the use of airbags.
- The airbags used for the lift were as specified in the ARM, but due to the angle presented between the wing and the top surface of the airbags, they tended to slide against the wing as the aircraft was raised. This problem was mainly associated with the bags sliding in the chordwise direction. After a lengthy period in which the problem was re-considered and further attempts made, it was decided to supplement the ARM procedure by using 'railway sleepers' to shore beneath the engine nacelles. The latter, particularly the No 2 nacelle, had been damaged during the ground slide and there was damage to the No 2 pylon which was visible as distortion, and so there was some concern about this procedure, however it seemed the best alternative and subsequently proved to be so.
- Once the wing was high enough to place jacks at the jacking points, two further problems were encountered. Firstly, the runway surface bearing strength was theoretically marginal for the loadings imposed by the jacks. These jacks were of 72.3 tonnes maximum capacity and would generate high foot loadings which although acceptable in a hangar might not be acceptable on many runways. However in practice no such problems were encountered. Secondly, the jacks fitted into ball and socket type jacking pads beneath the wings. As the aircraft was progressively lifted, a side load was imposed upon the jack which rapidly became unacceptable. This required further shoring, repositioning of the jack and re-jacking, which was time consuming. Finally it was found that the geometry of the retraction arc and the nature of the shortening mechanism on the landing gear meant that to lower the gear fully the left wing had to be jacked much higher than normal. This greatly exacerbated the problems with the jack and aircraft geometry. However once the aircraft had been successfully jacked, the left main landing gear was readily fully extended, the wheels on the right gear were quickly changed and the aircraft was towed off the runway. The recovery operation, which commenced on the evening of the accident, was not completed until around 9 am on the following morning.

- Difficulties had been experienced with the ARM procedures previously. On 11 July 1997 another A340 departed the runway at Kinshasa and became bogged down in sand. Similar difficulties with airbags were encountered.
- On 29 August 1998 an A340-200 suffered a fracture of the right main landing gear whilst landing at Brussels. The aircraft dropped onto the right-hand engine nacelles and departed the runway to the right, coming to rest on the grass with the nose of the aircraft some 155 metres to the right of the runway centreline, despite nosewheel steering being available. Similar difficulties were experienced with lifting the aircraft, exacerbated by the unpaved surface upon which the aircraft came to rest, and the damaged right main landing gear. During the ground roll and departure from the runway, the crosswind component was from the right at about 5 kt, this being from the same side as the damaged landing gear. The significance of this is discussed later.
- As a result of the lessons learnt from these three recoveries, the manufacturer is conducting trials to optimise the airbag procedures. Also, low profile tripod style recovery jacks have since become available which have the required capacity, can be fitted beneath the wings and which have the ability to accommodate the lateral displacement necessary to avoid side loading of the jack. Airbus Industrie is also conducting testing on the A320 with the aim of allowing that aircraft to be lifted by attaching strops to the sidestay cardan pin through the top of the wing, thus permitting the use of a mobile crane of sufficient capacity.
- Airbus Industrie conducted a review of the ARM procedures and scheduled related trials for early 1999, following which the ARM was to be revised accordingly.
- **1.19 New Investigation techniques**
- None.
- **2. Analysis**
- **2.1 Operation of the aircraft**
- **2.1.1 Crew qualifications, experience and training**
- All three pilots were properly qualified and experienced in their respective roles to operate this flight. They had each had a period in excess of 48 hours rest prior to reporting for duty at 0330 hrs at Los Angeles International Airport.
- They had all undergone the operator's standard training programmes, which included initial and appropriate recurrent simulator instruction in the handling of abnormalities with the deployment of the A340 landing gear. This simulator training had not gone as far as to practice any landings with any main landing gear not deployed, as QRH procedures current at the time were considered to be adequate to ensure that satisfactory deployment of a non-fully extended landing gear would occur as a result of the crew carrying out the QRH 'Gravity Extension' procedure.
- **2.1.2 After take off**
- The crew considered that nothing unusual in the operation of the aircraft had occurred during the departure phase from Los Angeles. After take off, they had noted that the landing gear was a little slower than usual to retract fully, but there were no abnormal alerts or other indications of a landing gear problem, because they were suppressed while the aircraft was below 1,500 feet agl. By the time the aircraft had climbed through this height, the abnormal condition indications had cleared and so no subsequent warnings were generated.
- Later in the flight, when the aircraft systems status pages were being routinely reviewed, it was noted that the inner rear left wheel (No 6) brake temperature indication showed a 'no signal' condition. This had been experienced with other brake units on previous occasions and was considered to be merely a fault associated with the indication system rather than any real landing gear anomaly.

- The first tangible evidence of a landing gear abnormal condition occurred as the landing gear was being deployed some 8 nm from touchdown on approach to London Heathrow Airport at 1504 hrs, almost 10 hours after take off.
- 2.1.3 The initial go-around
- In response to the ECAM alert indication 'L/G GEAR NOT DOWNLOCKED', the crew realised that the initial selection may not have produced a full extension of the landing gear. The crew therefore correctly decided to execute a go-around and the aircraft was given radar vectoring to return to the holding fix at Bovingdon VOR. This gave the crew time to carry out the necessary troubleshooting actions, including reference to the QRH for the 'L/G Gravity Extension' procedure.
- 2.1.4 The hold, troubleshooting actions and communications
- It was fortunate that the aircraft was within VHF radio range of its company Operations Department, where full managerial and engineering support was provided. A series of suggestions were passed to the commander in an attempt to overcome the landing gear problem. After exhausting all possible combinations of pulling and resetting the LGCIU and other circuit breakers, recycling the landing gear selector lever, using the gravity extension procedure etc, the crew were faced with the likelihood of having to perform a landing with an abnormal main gear configuration.
- During the troubleshooting phase, the aircraft was in contact with the Heathrow Terminal Controller at LATCC on a discrete frequency, in order that other aircraft transmissions did not interfere or block communications with G-VSKY. During their debrief, the crew expressed appreciation for this facility, but commented that it did leave them somewhat unaware of the potential traffic situation surrounding them. However, this aspect was being monitored by ATC and relieved the crew of an extra responsibility at a time of very intense workload.
- 2.1.5 The flypast
- It was not possible for the crew to observe the status of the landing gear from anywhere on board the aircraft. In order to fully assess the condition of the landing gear prior to the final approach the commander, in consultation with the operator's engineering and management representatives, elected to carry out a flypast of the Heathrow Control Tower in order that the gear status could be observed from the ground. In order to prepare the aircraft for the flypast, both the normal and 'Gravity Extension' Checklists had been actioned, so that as much of the landing gear as possible was extended.
- The aircraft was given radar positioning for an ILS approach to Runway 27R, breaking off at about 300 feet agl in order to fly close to the central area of the Airport. When the aircraft was approaching the Tower, the commander banked the aircraft to the right in order that the underside was fully exposed to view. A
- company engineer was in the Tower to observe and noted the status of the left main gear hanging in the gear bay. This information was passed to the crew by ATC.
- The engineer requested a second opportunity to view the landing gear but an aircraft departing from the parallel Runway 27L at about the same time prevented the commander of G-VSKY from turning the aircraft around in a tight left orbit to conduct a flypast from west to east. At about this time, the aircraft's fuel system generated a 'low fuel quantity' alert on the ECAM (indicating some 5,400 kg total contents remaining).
- Discussion had already taken place, between the commander and company management, about the possibility of diverting the aircraft to Manston. The commander had been informed that Manston had been alerted and was ready to accept the aircraft. When the 'low fuel quantity' alert occurred, the commander elected to abandon any plan to carry out a further flypast, or to divert the aircraft to an unfamiliar airfield. These decisions were entirely reasonable in the circumstances.

- 2.1.6 Aircraft manoeuvring
- In a final effort to assist the landing gear to extend, it was suggested that the aircraft be manoeuvred so that additional 'g' loading was applied. The aircraft's flight control system is, however, designed to limit the additional 'g' loading and angle of attack that may be applied in flight by pilot input, in order to keep the aircraft within the allowable flight envelope. The maximum 1.46 g loading applied during the manoeuvring and the maximum angle of attack of 10° were both within normal operating limits and were not restricted by the flight control system's automatic protection features.
- The small amount of manoeuvring that was carried out did not produce any significant change in the status of the landing gear. From subsequent examination of the nature of the gear problem, manoeuvring the aircraft was unlikely to have extended the gear.
- Until just prior to the manoeuvring of the aircraft, liaison with the cabin crew and passengers had taken place at intervals in order to keep them informed of what was occurring. However after the flypast, events developed quickly and the cabin crew were in the process of briefing the passengers on the manoeuvres to be carried out when they occurred. This caused a little consternation amongst some of the passengers who were, by this time, becoming concerned.
- 2.1.7 Planning for the final landing
- The commander elected to remain at Heathrow for the final landing and decided that the next approach would be to a full stop landing. The commander formally declared 'Mayday' status at 1608 hrs, effectively giving the aircraft absolute priority at Heathrow. Other inbound aircraft were held in the four holding stacks around the London area. Runway 27L was offered by ATC, in conjunction with Heathrow Airport Limited, so that any potential directional swing due to contact between the engines and the runway would not cause the aircraft to yaw towards the central terminal area. There was a crosswind from the south prevailing at that time, with about 10 kt crosswind component. Full emergency services deployment was rapidly achieved and the area on each side of the landing runway was rapidly cleared of other aircraft, personnel and mobile equipment.
- There was no question of the commander being refused permission to land at Heathrow in these circumstances, although the airport operator would have preferred the aircraft to have diverted elsewhere in order to minimise disruption to other services. A late question to the commander from the controller concerning a possible diversion caused a little momentary confusion, but this had occurred due to timing delays in information exchanges between the controller, the airport operator, the aircraft's operator and the flight crew.
- Having decided to land the aircraft at Heathrow, the commander supervised the final preparations for the approach. The CRP noted that, after the flypast, the centre landing gear was still deployed. This landing gear, consisting of two main wheels on a single axle which is located on the aircraft centreline between the two main landing gears, is not designed to accommodate the asymmetric loads that would be applied in the event of the aircraft pivoting about the centre gear after touchdown. Failure of the leg is likely in such a situation. For this reason, in this situation use of the centre landing gear was expressly prohibited in the FCOM, Volume 3. However, this was not reflected either on the ECAM or in the QRH procedure and it was fortunate that the CRP had reference to the Volume 3 at that time.
- In order to ensure that the aircraft was in the correct configuration for landing and that all necessary checks had been correctly carried out, the commander requested an orbit in order to give the crew additional time in which to carry out a review of the required actions in the QRH.
- The landing gear was therefore retracted and the 'Gravity Extension' procedure was repeated. The centre landing gear remains retracted in such circumstances and nosewheel

steering is rendered inoperative. In addition, the main and nose landing gear doors remain open after this procedure.

- The crew then reviewed the 'Landing with Abnormal Landing Gear' QRH procedure. The fuel state at the time rendered consideration of fuel jettison irrelevant and the option of a diversion had become imprudent.
- The commander's decision to modify the aircraft QRH with respect to the engine shut down sequence was entirely prudent, since he wished to retain the aircraft electrical and hydraulic systems for as long as possible in order to maintain the flight controls. The decision to shut down the No 1 and No 4 engines on touchdown was to ensure that symmetric thrust was maintained. Use of reverse thrust was not an available option. No 2 engine was to be shut down as the aircraft's left wing dropped, to reduce the risk of fire. Operation of the No 3 engine was retained for as long as possible to provide power for the flight control computers and related systems, consistent with having all engines shut down during the final stage of the landing roll.
- The crew were unsure of the possible effect of the abnormal LGCIU sensor indications on the BSCU and the flight control computers. When the right main landing gear wheels indicated 'on ground' (with weight on the wheels and wheel spin up), with the left main landing gear signalling 'in flight' (ie no weight on the wheels and no wheel spin-up sensor indications), conflicting status information would be sent to the BSCU and the flight control computers.
- 2.1.8 Flight control system during the landing phase
- The commander performed a balanced, gentle touchdown on the right main landing gear on Runway 27L, to the right of the centreline, close to the touchdown zone with a crosswind from the left side of the aircraft. The landing was recorded on video by the attending emergency services.
- Some 9 seconds after touchdown the aircraft had been banked gently to the right, to increase the time before the left wing would lose lift and cause the left engine pods to contact the runway. However as the aircraft pivoted about the right main landing gear, the No 4 engine pod had contacted the runway briefly. The roll angle at which this contact is predicted to occur is given in the FCOM, Volume 1 as  $14.5^\circ$ , at a pitch attitude of  $7^\circ$  (Appendix 25). Information derived from the DFDR indicated that the maximum bank angle achieved during the landing (at a sample rate of twice per second and a maximum observed roll rate of  $3^\circ$  per second) was  $10^\circ$ . The manufacturer indicated that the diagram was valid when aerodynamic lift loads were being applied to the wings. It was pointed out that this situation was not necessarily valid in the dynamic landing case. The manufacturer agreed to review the content of the diagram.
- The most probable reason for the bank to the right was derived from examination of the behaviour of the roll control system under these landing conditions.
- The flight control Lateral Normal Law normally changes to Lateral Ground Mode over a period of some 2 seconds after touchdown (defined by LGCIU 'on ground' sensed signals and pitch attitude less than  $2.5^\circ$ ). In Lateral Normal Law, the flight control system uses pilot's side stick lateral input to signal a demanded roll rate. In Lateral Ground Mode, the relationship is conventional, ie lateral side stick input to direct aileron and spoiler control deflection dependent on aircraft speed, to achieve a desired roll attitude.
- In Lateral Normal Law, an automatic turn co-ordination and yaw damping function is provided by electronic signalling to the rudder actuator.
- In this case, because of the discrepancy between Nos 1 and 2 LGCIU's ( No 2 'on ground', No 1 'in flight' ) the change of law/modes did not take place. At this stage, the commander was beginning to apply right side stick in order to keep the left wing up as long as possible. This was probably seen by the flight control system as a demand for right roll rate, and the



available roll control surfaces were deflected accordingly. The rudder turn co-ordination and yaw damping functions were also still active.

- During a normal landing, some two seconds after passing through 100 feet Radio Altitude, the Pitch Normal Law changes to Pitch Flare Law. On touchdown, there is a further change to Pitch Ground Mode over a period of some 5 seconds after touchdown (defined by LGCIU 'on ground' sensed signals and pitch attitude less than 2.5°). In this case, the flight control system would have remained in Pitch Flare Law, which is effectively Pitch Direct Law with some damping provided by load factor and pitch rate feedbacks. The difference in pitch handling characteristics would not have been marked and is unlikely to have affected the outcome of this event.
- The flight crew had no indications available to inform them of this abnormal flight control status.
- 2.1.9 Hydraulic and electrical systems during the landing phase
- Because of the chosen engine shutdown sequence, hydraulic system power was maintained until after the point where aerodynamic control was lost. Each engine would have ceased to deliver hydraulic power almost immediately after the Engine Fire Pushbuttons were used (due to closure of the hydraulic fire shut off valves) and hydraulic power would only have been available from the RAT, which was unable to deliver sufficient power as the speed reduced. The flight recorder data showed that hydraulic power was still available when the recorder went off-line due to generator shutdown without the APU running, some 19 seconds after touchdown, by which time aerodynamic control was no longer effective.
- The commander had thus selected a good strategy for the engine shutdown sequence and this procedure was subsequently adopted as the manufacturer's recommended technique, reflected in the revised QRH, which was intended to preserve the residual hydraulic flow from the engine driven pumps for as long as possible when the engines are windmilling and running down due to inertia.
- Likewise, the electrical power was maintained for as long as practicable. The four engine driven generators would have gone off-line within about one second of respective engine shutdown. The RAT would have been unable to power the emergency generator below about 100 kt. Battery power alone would have provided the AC and DC Essential busbars. The DC busbars 1 and 2 would no longer be powered. From the recorded data, it appeared that the CVR and DFDR lost power some 19 seconds after touchdown, while the indicated airspeed was still about 105 kt.
- With the loss of the DC2 busbar, the flight control computers PRIM 2, PRIM 3 and SEC 2 would have gone off-line, leaving only PRIM 1 and SEC 1 available. If the APU had been running, then all five flight control computers would have been available. However, the manufacturer considered that the additional risk of a possible APU fuel system fire outweighed the benefits of improved flight control availability during the final phase of the landing.
- Thus, with the shutting down of the last engine (No 3) and with the aircraft still moving at about 105 kt, hydraulic power and electronic flight control systems became ineffective in controlling the aircraft.
- Once the Green system hydraulic pressure had been lost, no nosewheel steering was available. In any event, because the 'Gravity Extension' QRH procedure had been accomplished, nosewheel steering was not available for any part of the ground roll and the nosewheel was free to castor.
- No braking was available for the maximum wheel spin-up period of 16 seconds after touchdown because the BSCU was in 'Aquaplaning Mode', due to the wheels on the left main landing gear not having spun-up since they were not in contact with the runway.

- Antiskid braking then became available using the BSCU internal reference wheelspeed, until either hydraulic power from Green and Blue systems was lost, or until the DC1 and DC2 busbars failed. This would have caused both of the BSCU channels 1 and 2 to fail, rendering antiskid inoperative. Alternatively, when the reference wheelspeed became less than 0.98 times the aircraft speed, the BSCU would have terminated the antiskid function. The manufacturer's analysis indicated that the BSCU logic would have terminated antiskid braking after 22 to 23 seconds from touchdown due to loss of reference wheelspeed validity.
- It was not possible to deduce which of these events occurred first but they all result in direct braking, without antiskid or autobrake, coming into operation. The applied brake pressure was then sufficient to burst all four tyres on the right main landing gear. This in turn adversely affected the crew's ability to stop the aircraft, or to control it directionally.
- Following this accident, the appropriate QRH procedure was revised to require the deselection of the antiskid system, and the advice to crews to use a maximum applied brake pressure of 1,000 psi has been added. This will ensure that the basic remaining braking capacity is retained throughout the landing phase and that excessive brake applications will not burst the tyres.
- 2.1.10 Directional control after landing
- A concern arising from this accident was the issue of directional control during such a landing, when considering the possible effects of the aircraft, and particularly an outboard engine, colliding with obstacles that may be present off to the side of a chosen runway.
- The systems engineering design is such that, after final engine shutdown the only means of directional control is by judicious application of the remaining brakes as, by this stage, the aircraft speed is assumed to have reduced below the minimum for significant aerodynamic effectiveness of the remaining flight controls, particularly the rudder.
- The analysis performed by the manufacturer and presented in Appendix 23 is of considerable importance when selecting a runway direction for landing. A favouring crosswind will allow directional control to be maintained, while an adverse crosswind will present potentially serious lateral deviation problems. Zero crosswind conditions will still lead to directional problems if the friction on the nacelles is high and the landing weight is close to the maximum permitted.
- In this case, the commander succeeded in keeping the aircraft on the runway, despite an adverse crosswind component of some 13 kt.
- In the case of another A340 landing accident (section 1.18.9), the light crosswind was from the unfavourable direction. Since directional control is not guaranteed, even in zero crosswind, this additional adverse factor would have been important and could explain why, even with nosewheel steering available, that aircraft departed the runway and came to rest with its nose some 155 metres to the right of the runway centreline, although there was the element of surprise as the crew were not prepared in advance of the occurrence.
- The manufacturer's study also showed that stopping distances will increase by about 11.5% at Maximum Landing Weight, which is within the normally accepted factor used in the calculation of landing performance when considering the suitability of a particular runway for normal operation of the aircraft.
- Considering that the A340 has a semi-span (from aircraft centreline to the outboard engine nacelle) of about 19.6 metres, and the standard runway semi-width is 22.5 metres, under normal circumstances the outboard engines are only some 2.9 metres inboard from the runway edges with the aircraft on the runway centreline.
- Runway design specifications also call for a minimum shoulder width of 7.5 metres along each side of the runway. To each side of the paved runway/shoulder surface, there should also be a graded 'runway strip' extending to 150 metres from each side of a precision

approach runway, which is obstacle free and graded out to a distance of 105 metres, although it is accepted that certain airfield equipment may be required to be located in such areas.

- In this case, G-VSKY was deliberately positioned for landing with the right main landing gear biased towards the right side of the runway. The maximum clearance available therefore between the No 1 engine nacelle and the left-hand edge of the runway was about 21 metres. However this would only have been achieved with the right main gear at the right-hand edge of the landing runway. Concrete shoulders, 22.5 metres wide on each side, are present along Runway 27L at Heathrow, which could have been very beneficial in this case. However, this shoulder width is not standard and may not be present to such an extent at other airports. As a result of such findings, the following safety recommendation is made:
- Airbus Industrie should consider a revision to the QRH 'Landing with Abnormal Landing Gear' procedure to include reference to the considerations of crosswind and choice of landing runway.
- 2.1.11 Flight crew aspects
- The flight crew were faced with handling a serious emergency towards the conclusion of an overnight transatlantic flight, having been on duty for about 12 hours.
- From assessment of the tape recordings of their communications with ATC, and from the CVR, it was apparent that the three pilots worked well together as a coherent team, successfully implementing the ordered division of duties which is positively encouraged during Crew Resource Management training. Each pilot was able to make a valuable contribution to the team and displayed a high degree of initiative and motivation.
- The commander was able to communicate directly with the company operations department by VHF radio link. This was undoubtedly beneficial in providing 'non-stressed' thorough support, which assisted him in the extensive decision making chain that evolved. He was not subjected to any undue pressure to carry out a particular course of action, and was given full support by company management once his decisions had been made.
- The presence of the third pilot on the flight deck, who was not directly involved in the aircraft handling, navigation or communication with ATC or the company management, provided a useful alleviation of workload for the two 'operating' pilots. He was able to take on the responsibility for liaison with the cabin crew and to seek out the appropriate reference material from the Flight Crew Operating Manuals where necessary. He also noticed, prior to the final landing, that the centre landing gear was not in the correct configuration for landing in such circumstances. Had this not been noted and the aircraft landed with the centre gear extended, then more extensive aircraft damage could have occurred.
- After the flypast had taken place and the fuel system 'low level' alerts had initiated, the workload increased markedly. There was an almost continuous stream of communication between the aircraft, ATC, the company and the flight deck crew members. Once the decision to make a final approach and landing had been made, the commander wisely requested an orbit so that the crew would have the requisite time to complete all of the necessary QRH procedures and the appropriate passenger briefings.
- The cabin crew carried out their duties efficiently and effectively. Passenger briefings were given regularly as updated information was passed from the flight deck. Passengers were briefed on the progress of the flight and the intention to carry out the low flypast. The briefing concerning the aircraft manoeuvring was slightly late but this appeared to have caused little more than mild discomfort for those passengers relatively unfamiliar with flying.

- Shortly after this, the briefing for the final landing was given and the cabin crew successfully carried out the calls to the passengers to adopt the brace position for landing. After the aircraft had stopped, the evacuation was initiated by the commander.
- After the successful evacuation, a number of passengers expressed their gratitude to the crew for their handling of the situation.
- 2.1.12 Emergency lighting
- During the preparations to land, the emergency lighting was demonstrated, probably using the Purser's switch. The ON selection of the NO SMOKING sign switch on the flight deck overhead panel from the time of completion of the Landing with Abnormal Landing Gear QRH Checklist, Preparation items, would have prevented re-charging of the associated internal batteries. Thus the emergency lighting could have been operating from the internal batteries for a significant period of time. These internal batteries have a normal operating capacity of some 12 minutes.
- It was concluded, therefore, that these batteries had become discharged during the preparations to land and were prevented from recharging because the NO SMOKING sign switch was in the ON position. Revised QRH procedures have since been introduced by Airbus to prevent a recurrence of this situation.
- 2.1.13 Door opening and slide deployment
- During the door tests under maximum loads, the non-linear behaviour of the system gave the impression that the door had 'hung' at between 20 to 30 degrees. The period of time over which this would have occurred was such that, in an emergency situation, failure of the door operating system could have been a reasonable assumption.
- However, it was considered that the test under actual conditions did not represent what had actually been observed, since the cabin crew member had reported that there had been time to call for passenger assistance. Possible reasons for this could have included additional forces due to variability in the slide packaging and varying wind conditions, however it appeared unlikely that any other physical factors were involved.
- It was thus considered probable that the perceived failure of the door was associated with the non-linear behaviour of the system. Upon pushing the door a proportion of its weight, together with the slide forces and any other effects, would become apparent. These conclusions were confirmed when the conditions were replicated aboard G-VSKY with the cabin crew members present.
- In addition it became apparent that the cabin crew member would have begun to push the door as soon as it appeared to stop opening. This action would have reduced the potential assistance from the gas charged cylinder, the action of which would have been lagging behind the door position as its gas pressure built up, leaving the cabin crew member to manage the door in effect without mechanical assistance.
- However, had she stopped pushing (which of course would have been contrary to her trained response), the gas actuator pressure would have built up and continued to open the door automatically.
- It was clear that the training simulator operated differently to the real aircraft doors and did not exhibit the same non-linearity in operation. The training aid was thus unrepresentative of the doors on the aircraft.
- As a result of these findings, the following safety recommendation is made:
- The CAA, FAA and JAA should review the requirements for public transport aircraft cabin door simulators used for crew training to require that they accurately simulate any non-linear characteristics of the associated aircraft doors and to require that full instruction is given to cabin crews regarding the door operating characteristics to be expected when operating the doors in an emergency.
- 2.1.14 Consideration of a possible diversion

- Early in the sequence of events, the company's Operations Department became aware of the problem with the aircraft's landing gear. They were also aware that if it was necessary to land the aircraft with one main landing gear retracted, the aircraft would then obstruct the associated runway for some considerable period. The potential inconvenience to passengers and other operators was appreciated.
- For these reasons, the company management attempted to locate an airport suitable for the emergency landing, and Manston was suggested because of its relatively wide runway which could have been beneficial in these circumstances.
- Arrangements were made with Manston ATC to accept the aircraft and to bring their emergency services to maximum alert status. Unfortunately, the highest status available was RAF Category 7, which was approximately equivalent to CAA Category 6. The company Operations Manual specified that the A340 required a CAA Category 9 status, with occasional operations permitted from Category 8 airports (although, implicitly, this was not for the type of premeditated emergency landing presented in this case ).
- The Operations Manual did not contain a comparison of CAA and RAF categories, although this anomaly was resolved during the course of this investigation. Both the company's and the aircraft's navigation chart libraries did however contain such a table of comparison in their Flight Guide publication.
- If the commander had elected, on company advice and arrangement, to divert to Manston, then he would have contravened the requirements stated in the Operations Manual.
- From a practical viewpoint, there is little doubt that Manston's emergency services could have coped perfectly adequately with this emergency landing. However, in the case of a large passenger aircraft carrying out an emergency landing in somewhat more adverse circumstances involving, for example, structural or controls system damage and/or associated fire, the emergency facilities may have proved inadequate.
- 2.1.15 Consideration of alternate landing airports
- During the recovery of the aircraft from the runway at Heathrow, the airport's available movements capacity was reduced from the normal average of about 71 per hour to about 54 movements per hour. At peak times, with favourable weather conditions and an optimum mix of aircraft types, the movement rate can often reach some 82 movements per hour. Thus, in the event of an aircraft blocking one of the runways for a significant period of time, the airport's operating capacity can be reduced by between 25 and 35% with single runway operations. This leads to delays and flight cancellations. The latter effects are essentially commercial and cannot be permitted to influence the prospects for the safest landing option in such emergency circumstances.
- However, there is also a potential safety issue when considering the effect of such an emergency on Air Traffic Controller workload and system capacity in the crowded airspace around the south-east of England. In this case, at the time that Heathrow went to single runway operations, after only a short period of prior notification that this would occur, many other aircraft were arriving in the London
- Terminal Manoeuvring Area (TMA) intending to land at Heathrow. These aircraft were duly instructed to enter the usual four holding patterns around London until they could be fed into the reduced landing traffic flow.
- The resultant immediate problem was rapid congestion of the available Flight Levels for the stacking of aircraft after single runway operations had commenced. Aircraft which continued to approach the TMA were therefore requested to enter holding patterns further away from London until the congestion in the stacking patterns had reduced sufficiently.
- There followed a period when it became apparent to some aircraft crews being held in the stacks that they did not have sufficient fuel reserves to continue to hold for a prolonged

period, and that diversion to other airports in the UK would be necessary. ATC workload again increased as these aircraft were appropriately routed away from Heathrow.

- The flow control system had been activated and slot times allocated for arriving traffic. These flow rates were adjusted to take into account the expected landing rates that could be achieved with single runway operation at Heathrow. Thus, within the first few hours after the accident, the ATC system had adapted to cope with the situation and a more regular traffic flow, albeit at reduced flow rates, was restored.
- This type of situation can, of course, occur at anytime due to an aircraft technical problem or when urgent ground work is required and is in progress on a runway. The ability of the ATC system to retain flexibility and to have sufficient personnel and airspace capacity to cope with these situations is therefore of paramount importance from a safety standpoint. On this occasion, the situation was handled well and whilst the resulting delays and cancellations were commercially detrimental, no Airprox or other incidents arose as a result of this runway closure.
- The ATC system should be so managed and resourced that it is able to safely adapt at all times to these types of traffic handling problems which may suddenly arise from reduced landing capability. The commanders of other aircraft should be expected to take timely decisions regarding diversion due to fuel reserves.
- Appendix 26 shows the 1997 Total and Air Transport Movements for the busiest 20 of the UK international airports. It is noteworthy that currently only Heathrow has a two runway normal capacity.
- The effect of an aircraft with damaged landing gear carrying out a diversion to another UK airfield and then causing a prolonged runway blockage would be to completely close that airport for all operations, until the aircraft was removed, with the possible exception of Runway 08L/26R at London Gatwick.
- Another aspect associated with such landing gear related emergency landings at major airports concerns the proximity of runways to other aircraft and buildings. While in this accident, and other instances of aircraft landing with landing gear problems in the past, aircraft have generally remained on (or close to) the landing runway, this may not always be the case if, for example, an outer engine nacelle makes early ground contact off the runway and generates sufficiently high yaw forces to swing the aircraft off the runway. In order to completely avoid this possible potential for ensuing ground collision(s), such emergency landings would therefore ideally be conducted on a runway which is sufficiently separated from other aircraft on the airport, ground vehicles and airport buildings etc. that such secondary collisions were precluded.
- As a result of such factors, the possibility was considered of nominating a large government owned airfield as an alternate landing location. Such use would raise questions over the runway suitability, navigation and approach aid availability, level of emergency services cover available (on a 24 hour immediate readiness basis), post-evacuation passenger handling facilities, ground/recovery equipment available and the infrastructure and facilities subsequently required to render the aircraft serviceable for flight.
- However, if one particular airfield were to be nominated as a preferred alternate landing location it may be the case, at the particular time that it was required, that the prevailing weather conditions might render that location less than optimum for the nature of the related aircraft problem. Such a nominated alternate might therefore lead to additional pressure on the commander of an affected aircraft. However, commanders may choose to conduct an emergency landing at another such airfield if they decide that the associated facilities and landing conditions are acceptable.
- It was therefore concluded that, notwithstanding the related potential ATC and other problems discussed above, the commander of a public transport aircraft which requires an

emergency landing should not be unduly influenced by these wider issues which may arise by virtue of his decision to land. It should therefore remain the absolute responsibility of an aircraft commander to make the decision as to which airport to nominate for an emergency landing, taking into consideration the prevailing weather conditions, runway suitability, RFF category, aircraft fuel state and any other factors relevant to the emergency at the time. Assistance can, of course, always be sought from ATC in providing the latest information regarding airport availability and weather conditions.

- 2.1.16 Consideration of QRH procedure
- During this investigation the content of the QRH, especially with regard to the section 'Landing with Abnormal Landing Gear', was reviewed and it was considered in the context of preserving essential electrical and hydraulic systems for the maximum possible time consistent with the reduction of overall risk to the aircraft.
- The original QRH procedure (as referred to by the crew during this event) is shown in Appendix 2. The manufacturer's revised QRH procedure, introduced during the course of this investigation, is shown in Appendix 27.
- The following paragraphs indicate the changes introduced, and the associated reasoning for these changes:
  - **Jettison:** Recommended fuel jettison action reduced for commander's consideration.
  - **GPWS System:** Moved from 'Preparation' section to 'Approach' section in order to preserve a vital terrain avoidance safety aid for as long as possible at a time of high crew workload (and thus possible distraction) while the aircraft would be operating at holding altitudes which may be in close proximity to Minimum Safe Altitudes for terrain around a particular airport.
  - **L/G Gravity Extension:** Sequence changed to reflect the correct method of operation of the 'Gravity Extension' system.
  - **Autobrake:** 'Do Not Arm' because Normal braking system will not be available with Anti-Skid and Nosewheel Steering switched OFF.
  - **Emergency Exit Lights:** 'ON', to ensure operation with battery supply reversion available when DC ESS bus fails.
  - **Commercial (Bus):** 'OFF' selection moved from 'Preparation' section to 'Approach' section in order to preserve cabin communications systems for a longer period to enable adequate passenger briefing to take place using the normal facilities of the PA system.
  - **Braking:** Note added to maintain braking at a maximum of 1,000 psi (with no antiskid available) so that wheel skidding risk is minimised
  - **Ground Spoilers:** 'Do Not Arm', with one or both main landing gear abnormalities, ensures maximum effectiveness of available roll control during touchdown and landing roll.
  - **Engine Masters (All):** Engine shutdown delayed until aircraft touchdown and then shutdown sequence specified, as was successfully demonstrated in this accident.
  - **Engine and APU Fire Pushbuttons:** Operation of these now delayed until the aircraft has come to a stop in order to preserve residual hydraulic pressures for as long as possible. The actions performed by the operation of the Engine Fire Push Button are (for the respective engine): Aural Warning cancellation, Extinguisher Squib arming, Fuel LP Valve closure, Fuel Return Valve closure, Hydraulic Fire Shut Off Valve closure, Engine Bleed Valve closure, Pack Flow Control Valve closure and Generator deactivation and de-energisation.
  - The activation of the Engine and APU Extinguishing Agent is performed once the aircraft has come to a stop, which should ensure the maximum effectiveness of the agent.
- **2.2 The landing gear malfunction**
- The left main landing gear could not be lowered because the unrestrained No 6 brake torque rod had become trapped within the keel beam structure. Some damage to the keel beam structure and adjacent systems was caused by the contact with the rod. This damage

indicated that although the gear had successfully retracted, at some point during the retraction sequence the rod had fouled the keel beam, because the rod was unrestrained.

- Examination of the post-flight reports indicated that there had been an apparent problem immediately after gear retraction at Los Angeles and this was almost certainly as a result of the brake rod becoming detached. The failure to extend the left main gear in preparation for landing at Heathrow was entirely due to mechanical interference between the rod and the keel beam, and this also prevented gear deployment by gravity extension. Recycling the landing gear, and increasing the applied normal 'g', were ineffective because during the periods with gear selected UP the rod had jammed against the top of the keel beam, and while the gear was selected DOWN it had jammed against the bottom. The only possibility of releasing the jam would appear to have been during gear transit with lateral 'g' applied in the appropriate sense, which is not a recognised procedure.
- The lack of any other damage to the rod indicated that the brake rod had not contacted the runway after it had disconnected, and had thus detached at least a short time after lift off, most probably as the landing gear was being retracted. There was no evidence of the missing parts in the landing gear bay, or on the runway at Heathrow.
- The Flight Data Recorder showed that, during the take off at Los Angeles, seven of the eight brake pressure traces recorded a normal increase in brake pressure due to wheel despin braking, which is performed automatically during the retraction sequence. However the last trace, that for the brake at position No 6, showed a reduction from residual pressure to zero. This was consistent with the application of despin braking after the brake rod had detached, which would have caused the complete brake pack to rotate, damaging the brake pressure line. At the same time, 0509 hrs UTC according to the post-flight reports, the problem with the landing gear doors failing to close occurred and the brake temperature sensor on the same brake also failed. Thus it was considered that the torque pin which had attached the brake torque rod to the brake pack had disengaged and dropped away between the gear leaving the runway and completion of the retraction sequence. The geometry of the torque pin and its installation orientation suggested that the most likely probability was that it had fallen out as the gear had retracted towards the horizontal plane.
- The search for the torque pin and associated retaining parts at Los Angeles International Airport was based upon the above reasoning and the successful discovery of the torque pin off the end of the runway substantiated this assessment.
- **2.3 Possible failure modes of torque pin retention**
- Initially all that was known was that the torque pin and its retaining hardware were missing. This led to early considerations that a maintenance error may have been involved, in particular that the cotter pin may not have been fitted. Recovery of the undamaged torque pin without any other parts attached and its subsequent examination permitted failure of the torque pin or of the retainer to be discounted. This focussed attention on the bolt, nut and cotter pin. Several scenarios were considered:
  - 1. *That the bolt had failed:* For a bolt which was correct to specification (and all the bolts inspected were found satisfactory) tensile failure would have required a tensile load in the bolt of at least the minimum ultimate load, 18.15 kN. The possible sources of such excessive end load in the torque pin were: (i) static structural loads due to braking torque; (ii) dynamic loads due to carbon brake characteristics; (iii) loads induced due to ground operations including taxiing, turning and gear articulation; and (iv) loads introduced during installation. These possibilities were then considered:
    - (i) It was evident that the plastic deformation present in the torque pin bore of the brake housing and the associated bush migration had occurred during braking and that consequently the torque pin and its retaining assembly could have been subjected to high axial loads which it was not designed to withstand. The bore deformation was considered to



be 'old' and it was displaced 180° from the area of the bore that would have been loaded during braking at the No 6 wheel position. This indicated that the deformation had occurred when the brake had been installed in another position, for example while it was installed on G-VFLY at the No 7 position, and where the direction of the braking loads would have been reversed. The subsequent installation of this brake at the No 6 wheel position on G-VSKY would then have been done with the torque pin bushes already migrated. In this condition, the axial clearance of the torque pin may have been lost and a clearance gap introduced between the bolted faces of the torque pin and its retainer when in the static condition. This would have reduced the operational load capacity of the torque pin retaining assembly since, with no contact between the torque pin diaphragm and its retainer, the axial load in the pin combined with the bolt pre-load could have approached the load required to induce tensile failure of the retaining bolt. However, the structural torque testing carried out and the associated static analysis did not indicate loads sufficient to account for all of the damage in the torque pin bore, or to exceed the allowable loads in the torque pin assembly, of which the bolt was the limiting strength element. It was therefore considered possible that some of the apparent deformation in the bore may have occurred after the torque pin had partly migrated, before it detached completely. However, even if the axial loads generated were not sufficient to induce a tensile failure of the bolt, repeated high axial loading may still have induced low cycle fatigue failure of the bolt. (The possibility that this lack of clearance could have caused the cotter pin to shear and the nut to 'back off' is discussed later).

- (ii) In view of the known torque / temperature 'gain' characteristics of this manufacturer's carbon brakes and their satisfactory service history on the A340 fleet, the dynamic behaviour of the brake assemblies was not thought to be a factor in this failure. The structural torque testing carried out by the manufacturer was considered to represent a limiting static case which could not be exceeded in a dynamic case, such as that induced by brake 'grabbing'.
- (iii) Consideration was given to the loads arising from turning, especially braked turns at low speed, but the braking conducted for the associated Airbus tests, even in the turns, did not record measurable increases in the axial loads in the torque pin retaining assembly bolt. The load cell measurement vs steering angle graph at Appendix 20, page 1, shows the increase in the recorded axial load with steering angle. Whilst the median line through these results showed a small rise from just over 12 kN to about 14 kN with steering angles of up to 80 degrees, the range varied from just over 10 kN up to some 18 kN, with the higher loads occurring around the 40 to 50 degree steering angles. The bolt had a minimum UTS of 18.15 kN, as discussed previously in section 1.16.2. In addition, taxi tests conducted without the torque pin retaining assembly fitted demonstrated that the torque pin migrated very readily during tight turns.
- (iv) This particular brake had previously been fitted in three other wheel positions on other A340 aircraft of this operator's fleet. Although it was not established if this torque pin and its retaining assembly components had remained with this brake during these changes, there may have been more than one opportunity for the bolt to have been inadvertently over-torqued during fitment of this torque pin.
- 2. *That the nut had failed:* Tests were conducted by the brake manufacturer which confirmed that failure of the threads would occur only at loads in excess of the minimum ultimate load for the bolt. In the absence of the nut, the possibility of it having failed due to over-torquing or due to a pre-existing material defect could not be discounted, however such failure modes would not account for all of the the torque pin bore deformation that was found (see later).
- 3. *That the cotter pin had failed:* The variety of types and sizes of cotter pin found during the fleet inspection raised concerns that the cotter pin fitted may have been incorrect. This,

and possible re-use of the retaining hardware, could have reduced the strength of the installation. The bolt and nut should not normally experience torsion loads in service because the brake rod should be able to pivot freely about the torque pin (for example during articulation of the landing gear bogie on take off) when the torque pin has been installed correctly. Loss of axial clearance (or 'end-float') for the torque pin can generate torsion loads in the torque pin. In addition, if the loss of torque pin clearance is such that the retainer and diaphragm have deflected so that only a reduced contact area exists at their interface, torsion loads generated by the brake rod on the torque pin would be transferred to the bolt and nut. This would maximise the transmission of torque from articulation of the gear into the bolt and nut. This condition would become likely if the bushes in the torque pin bore of the piston housing had previously migrated, as found in this case. If this condition existed, any shearing of the cotter pin and subsequent disengagement of the unsecured nut would probably have occurred within a short period of operation, particularly if an incorrect, undersize, cotter pin had been fitted. However, this torque pin retaining assembly had failed some 6 months after it had been installed in May 1997. Some intermediate condition, in which only part of the torque was transmitted to the bolt and nut, might account for this longer period of apparently normal operation.

- 4. *That the cotter pin had not been fitted:* The discovery that a cotter pin was missing from G-VSKY at this same wheel position, but with a different brake, during the fleet check in April 1997 could support this possibility. In a normal installation with the correct axial clearance for the torque pin assembly, a correctly torqued nut and bolt without a cotter pin would probably not be subject to sufficient torque loading in normal service to affect the security of the nut and bolt. Thus, even without the cotter pin, the assembly could function for a long period. The long period of operation between the fitting of this brake in May 1997 and the accident suggested that either the nut was correctly torqued, or that the cotter pin was fitted, or both.
- In considering the above possibilities, the two central facts were that some part of the torque pin retention assembly had failed and that there was deformation of the torque pin bore in the piston housing. While it was possible that these two findings were unrelated, it was considered that there was evidence of linkage. In the case of both G-VSUN (sections 1.18.6 and 1.12.2) and G-VSKY, brake rods had detached and the torque pin bores showed evidence of deformation. During the fleet inspections, no case of an unsecured torque pin or a damaged brake was found in isolation. It was established by subsequent analysis that the loads required to induce deformation of the torque pin bore would also approach the loads required to fail the retaining assembly bolt. In addition, as discussed above, the associated displacement of the bore bushes could lead to a loss of axial clearance for the torque pin and increase the axial and torsional loads on the bolt.
- If the failure of the torque pin retaining mechanism had occurred due to a random failure of the nut or due to omission of the cotter pin, damage to the torque pin bore could have occurred if the torque pin had partly migrated before it disengaged completely. However, such failures would not have produced the pre-existing deformation of the torque pin bores.
- The pre-existing nature of the bore deformation on the No 6 brake from G-VSKY was not only indicated by its 'old' appearance, but was consistent with its position relative to the applied brake rod loads which indicated that it must have occurred when this brake had been fitted at another wheel position (eg No 7 wheel position on G-VFLY ). As discussed earlier in 2.3.1 (i) and (iii) this deformation and associated bush migration would have led to a situation where the torque pin was fitted without adequate axial clearance and the pre-load on the bolt may have induced some deflection of the torque pin diaphragm and retainer. Under these conditions, the bolt could have experienced excessive axial loading during taxiing turns, in addition to torsional loads from brake rod rotation during landing

gear bogie articulation on take off and landing. Such loading may have been insufficient to induce tensile failure of the bolt, but it could have caused its failure in low cycle fatigue; or alternatively the cotter pin may have sheared under the influence of the torsional loads on the bolt with only minimal interface area contact between the torque pin diaphragm and the retainer. In the absence of the torque pin retaining assembly parts, it was not possible to positively establish the precise nature of the failure, but it was considered that the probable cause was encompassed within these latter mechanisms.

- As stated earlier in section 1.16.1, the certification requirements for the brake structural torque test were defined in TSO C26c. This TSO is intended to allow such brakes to be tested for certification purposes to demonstrate that they are satisfactory for operation and is focussed upon the test requirements for brake units. However, TSO C26c does not specifically call for the elastic characteristics of the wheel axle to be taken into account, despite the fact that axle deflections can give rise to increased loads in the brakes. In addition, the structural torque test permits, by implication, some permanent deformation in the brake, provided component failure does not occur during the 3 second maximum static load certification test. As a result of such omissions, the original certification testing of the brake failed to identify that higher than forecast loads, and particularly axial loads, would be generated in the brake unit torque rod pin in service. In view of these findings, the following safety recommendation is made:
  - The CAA, FAA and JAA in consultation should amend the aircraft wheel brake certification structural torque test requirements in TSO C26c, paragraph 4.2(b), to require the use of representative wheel axles or other means to reproduce the expected axle deflections and associated brake assembly loads arising in service, and a post-certification torque test strip examination of such assemblies to check for yielding deformation to verify loading behaviour.
  - Whilst the secondary fouling effect of the detached torque rod end clearly caused the landing gear problem in this accident this was not, understandably, anticipated during the design and certification process. However, since such fouling following a torque rod disconnection has been demonstrated in this case, it is concluded that such a failure case should be considered during the design process for wheel brake assemblies in future. In view of this, the following safety recommendation is made:
    - The CAA, FAA and the JAA in consultation should amend the requirements for the integration of the Failure Mode Analysis (FMA) of new design wheel brake assemblies by the aircraft manufacturer to take into account the potential secondary affects of torque rod disconnection upon landing gear operation, in order to assess the related risk of gear jamming due to torque rod fouling on adjacent parts. Where a potential for such torque rod fouling is identified, appropriate design action should be required to eliminate this possibility so that landing gear operation is protected.
- **2.4 Flight recorders**
  - 2.4.1 Loss of electrical power to flight recorders
    - Electrical power to both the FDR and the CVR was lost when all the engines were shut down during this emergency landing. In this context and as a result of recent high profile accidents where recorders stopped functioning prior to impact, there has been discussion within regulatory bodies as to whether FDRs and CVRs should be equipped with independent power supplies to enable recording to continue if electrical power is lost. For the FDR, however, many of the data sources are from the aircraft databus itself, or from electrical sensors and therefore if electrical power is lost so are the inputs to the FDR.
    - It would, however, be feasible to fit an independent power source to a solid state CVR. The new technology recorders have a much lower power requirement than the older tape-based systems. An independent power source could provide sufficient electrical power to the CVR

and the cockpit area microphone for a period of 10 minutes when normal aircraft power was not available. It would also not be necessary for such a power supply to meet the flight recorder impact requirements. The solid-state recorders have a 2 hour duration and therefore the impact on the duration of the CVR continuing to record 10 minutes after an accident would be less than it would be on an older 30 minute recorder. In view of these considerations, the following safety recommendation is made:

- In order that the maximum air safety benefit may be obtained from Cockpit Voice Recorders (CVRs) during incident and accident situations where associated aircraft electrical power supplies may be prematurely lost, the FAA and the CAA should commission a study to investigate the feasibility of fitting limited duration independent power supplies to solid-state CVRs.
- 2.4.2 Cockpit voice recorder duration
- Aircraft with a maximum weight of over 5,700 kg and with an individual certification date after April 1998 are required to be fitted with a CVR with a recording duration of 2 hours. This aircraft, certificated in 1993, had a CVR with only a 30 minute duration. Under JAR-Ops 1.700 regulations, implemented in April 1998, there is no requirement to retrofit aircraft with CVRs capable of the 2 hour duration of recording.
- A normal descent, approach and landing would require at least 30 minutes recording duration. Abnormal situations which require the aircraft to go-around, enter a holding pattern, or to substantially extend its normal flight time will invariably result in the loss of the recording of the initiating event. In the case of this accident, a 2 hour CVR recording would have provided the investigation team with a complete record of crew communications during the events leading up to the emergency landing. As a result of these considerations, the following safety recommendation is made:
- The JAA should extend the existing JAA-Ops 1.700 requirement, for aircraft above 5,700 kg and certificated after April 1998 to have a 2 hour duration CVR recording capability, to include a requirement to retrofit the same weight category of aircraft certificated on, or before, April 1998 with similar recording duration CVRs.

- **3 Conclusions**

- **(a) Findings**

- 1 The crew were properly licensed, adequately rested and medically fit to conduct the flight. The flight crew operated the aircraft within the company's normal Flight Time Limitations scheme limits.
- 2 The aircraft was fully serviceable before the flight and was loaded within normal operating limits.
- 3 The flight crew carried out all possible procedures recommended by the aircraft manufacturer in their attempts to fully deploy the left main landing gear and could not have fully deployed the left landing gear by any other means whilst in flight.
- 4 The commander's decision not to divert to an alternate airport at that stage of the flight was entirely prudent.
- 5 The manufacturer's Quick Reference Handbook procedure for 'Landing with Abnormal Landing Gear' did not afford flight crews the best information available prior to carrying out such an emergency landing.
- 6 The commander's decision to amend the QRH procedure before landing was prudent and provided an improved prospect of a successful landing with only partial main

landing gear.

- 7 The assistance provided to the commander by ATC on a discrete frequency was invaluable at a time of high crew procedural and communication workload.
- 8 The decision by Heathrow Airport Ltd and Air Traffic Control to offer the commander Runway 27L for landing was prudent in view of the associated judgement that the aircraft would tend to veer to the left during landing.
- 9 The Airport Emergency Services at Heathrow were properly alerted and fully prepared for the aircraft's emergency landing; their duties were performed effectively and efficiently.
- 10 The post-evacuation handling of the passengers and crew was efficient and effective. Only minor evacuation injuries were sustained by the evacuees.
- 11 The possible diversion of the aircraft to Manston Airport had been considered and the emergency services there were rapidly brought to the maximum available state of preparedness to accept the aircraft. However, the Rescue and Fire Fighting Category available was below the level required by the airline's Operations Manual.
- 12 The left landing gear had jammed due to the No 6 wheel brake torque rod having disconnected from the brake pack assembly and having become trapped within the keel beam structure of the gear bay.
- 13 The torque pin which had connected the brake torque rod to the No 6 wheel brake had disengaged during landing gear retraction as the aircraft had taken off from Runway 24L at Los Angeles International Airport and was later found in the area beyond that runway.
- 14 Deformation of the torque pin bore in the No 6 brake piston housing had occurred at some earlier time in the life of the brake unit before it had been fitted to this aircraft, and indicated that the braking loads transmitted through the torque rod in service had been greater than that anticipated during the design of the attachment assembly.
- 15 The bush displacement and bore deformation could have reduced or eliminated the required axial clearance of the torque pin assembly which would have generated axial and torsional loads in the torque pin and its retaining assembly; the torque pin had been designed to withstand shear loading.
- 16 Testing by the manufacturer confirmed that during braking the tensile loads in the torque pin were higher than predicted due to elastic deformation of the wheel axle, brake and torque rod. Load cell measurements showed that the average tensile loads in the torque pin retaining assembly bolt increased only slightly with steering angles up to 80 degrees, but the recorded values varied from some 10 kN to 18 kN, with the higher loads occurring around the 40 to 50 degree steering angles. The bolt had a minimum UTS of 18.15 kN,
- 17 The increased tensile loading on the torque pin retaining assembly could have overstressed or fatigued the associated bolt, or possible additional torsional loads due to brake rod rotation during bogie articulation could have sheared the cotter pin and permitted the unsecured nut to disengage from the bolt.
- 18 The cotter pins examined during the fleet inspections were of a range of sizes and

lengths, but in the absence of the torque pin retaining assembly parts there was no evidence to indicate that the cotter pin fitted had been incorrect.

- 19 Following the accident, the torque pin assembly was redesigned by the brake manufacturer using an analysis of a theoretical model incorporating a significantly larger axial load, with large fatigue and ultimate reserve factors.
- 20 Although this design of wheel brake assembly had satisfactorily passed the related certification wheel brake structural torque test to the requirements of TSO C26c paragraph 4.2(b), the latter did not require use of a representative axle or other means to reproduce the axle deflections which occur during aircraft braking in service, and did not require post-torque test strip assessment of brake assemblies for resultant evidence of overstressing deformation which did not produce component failure.
- 21 The reported problems in the opening of door 4R were due to a combination of aircraft attitude and crosswind, and the characteristics of the gas cylinder assist system which, after initial opening and slide deployment, suffers a transient lag in output during opening. Although the door opening time was within certification limits, the lag becomes apparent when rapid manual opening is being attempted by a cabin crew member during an evacuation.
- 22 The door on the training simulator operated differently from the real doors and did not exhibit the associated non-linearity in operation; all door slides functioned satisfactorily during test.

- **(b) Causal factors**

- The investigation identified the following causal factors:

- 1 Full deployment of the left main landing gear was prevented by the unrestrained end of the No 6 brake torque rod having become trapped in the keel beam structure within the gear bay, jamming the landing gear in a partially deployed position.
- 2 The torque pin which had connected No 6 brake torque rod to that wheel brake assembly had disengaged during landing gear retraction after take off from Los Angeles, allowing the unrestrained rod to pivot freely about the retained end.
- 3 The torque pin and its retaining assembly had been subject to higher axial and torsional loads than predicted during aircraft braking in service. These loads were the result of elastic deformation of the wheel axle, brake and torque rod, and due to assembly without the correct axial clearance as a result of prior undetected displacement of the associated bushes. The precise mode of failure of the retaining assembly bolt, nut and cotter pin could not be ascertained in the absence of these parts.
- 4 This design of wheel brake assembly had satisfactorily passed the related certification wheel brake structural torque test to the requirements of TSO C26c paragraph 4.2(b). However the latter contained no requirement to use a representative axle or other means to reproduce the axle deflections which occur during aircraft braking in service, and did not require post-torque test strip assessment of brake assemblies for resultant evidence of overstressing deformation which did not produce component failure.

- **4 Safety recommendations**

- The following safety recommendations were made during the course of this investigation:

- 4.1 Airbus Industrie should consider providing a revision to the QRH 'Landing with Abnormal Landing Gear' procedure to include reference to the considerations of crosswind and choice of landing runway.

Recommendation 2000-32

- 4.2 The CAA, FAA and JAA should review the requirements for public transport aircraft cabin door simulators used for crew training to require that they accurately simulate any non-linear characteristics of the associated aircraft doors and to require that full instruction is given to cabin crews regarding the door operating characteristics to be expected when operating the doors in an emergency.

Recommendation 2000-33

- 4.3 The CAA, FAA and JAA in consultation should amend the aircraft wheel brake certification structural torque test requirements in TSO C26c, paragraph 4.2(b), to require the use of representative wheel axles or other means to reproduce the expected axle deflections and associated brake assembly loads arising in service, and a post-certification torque test strip examination of such assemblies to check for yielding deformation to verify loading behaviour.

Recommendation 2000-34

- 4.4 The CAA, FAA and the JAA in consultation should amend the requirements for the integration of the Failure Mode Analysis (FMA) of new design wheel brake assemblies by the aircraft manufacturer to take into account the potential secondary affects of torque rod disconnection upon landing gear operation, in order to assess the related risk of gear jamming due to torque rod fouling on adjacent parts. Where a potential for such torque rod fouling is identified, appropriate design action should be required to eliminate this possibility so that landing gear operation is protected.

Recommendation 2000-35

- 4.5 In order that the maximum air safety benefit may be obtained from Cockpit Voice Recorders (CVRs) during incident and accident situations where associated aircraft electrical power supplies may be prematurely lost, the FAA and the CAA should commission a study to investigate the feasibility of fitting limited duration independent power supplies to solid-state CVRs.

Recommendation 2000-36

- 4.6 The JAA should extend the existing JAA-Ops 1.700 requirement, for aircraft above 5,700 kg and certificated after April 1998 to have a 2 hour duration CVR recording capability, to include a requirement to retrofit the same weight category of aircraft certificated on, or before, April 1998 with similar recording duration CVRs.

Recommendation 2000-37

- Inspector of Air Accidents

- Air Accidents Investigation Branch
- Department of the Environment, Transport and the Regions
- May 2000
- *All safety recommendations are required to be taken into consideration and where appropriate, acted upon without delay. Regulation 14 of the Civil Aviation (Investigation of Air Accidents and Incidents) Regulations 1996 sets out the statutory responsibilities of any undertaking or authority to which a safety recommendation is communicated.*
- Return to Inspector's Investigations (Formal Reports) IndexReturn to Air Accidents Investigation Branch IndexReturn to [DETR Aviation Index](#)Return to [Home Page](#)Web Site Terms



**L/G GRAVITY EXTENSION**

- MAX SPEED ..... 200 KT
- L / G GRVTY EXTN ..... DOWN

**CAUTION**

Both selector guards have to be open before selecting DOWN.

- L / G LEVER ..... DOWN
- GEAR DOWN indications ..... CHECK

*CTR GEAR remains retracted in case of GRAMTY extension.*

**CAUTION**

N/W STRG is lost.

**■ If successfull :**

The free fall system should not be reset to avoid undesirable effect such as further fluid loss in the event of a leak possible L/G unlocking in the event of a gear selector valve jammed in UP position.

NOTE : The free fall system may be reset in flight after use for training.

*Provided the green hydraulic system is available resetting the free fall system may permit to restore L / G doors closure and nose wheel steering operation.*

**■ If unsuccessful :**

- Refer to "LDG WITH ABNORMAL L/G" procedure.

NOTE : In all cases the free fall system should not be reset by flight crew on the ground following free fall extension.

## LDG WITH ABNORMAL L/G

## PREPARATION

- CABIN CREW ..... NOTIFY
- ATC ..... NOTIFY
- JETTISON ..... ON
- OXYGEN CREW SUPPLY ..... OFF
- GPWS SYS ..... OFF
- SEAT BELTS/NO SMOKING ..... ON
- COMMERCIAL ..... OFF
- CABIN and COCKPIT ..... PREPARE
  - . loose equipment secured
  - . survival equipment prepared
  - . belts and shoulder harness locked
- **if NOSE L/G abnormal**
  - CG location (if possible) ..... AFT
    - . 10 PAK from front to rear = + 2 %
  - T TANK FEED ..... ISOL
- **if one MAIN L/G abnormal**
  - FUEL IMBALANCE ..... CONSIDER
    - . Open all the X FEED and switch off the PUMPS on the side with L/G normally extended.
  - GROUND SPOILERS ..... DO NOT ARM

## APPROACH

- L / G LEVER ..... CHECK DOWN
- L / G GRVTY EXTN ..... CHECK DOWN
- CABIN REPORT ..... OBTAIN
- JETTISON ..... OFF

## BEFORE LANDING

- RAM AIR ..... ON
- BRACE FOR IMPACT ..... ORDER

## JUST BEFORE TOUCH DOWN

- ENG MASTER (all) ..... OFF
- **if NOSE L/G abnormal**
  - NOSE ..... MAINTAIN UP
    - . After touch down keep the nose off the runway by use of elevator.
  - BRAKES (compatible with elevator efficiency) ..... APPLY
- **if one MAIN L/G abnormal**
  - FAILURE SIDE WING ..... MAINTAIN UP
    - . Use roll control as necessary to maintain the unsupported wing up as long as possible.
  - DIRECTIONAL CONTROL ..... MAINTAIN
    - . Use rudder and brakes to maintain runway axis as long as possible.



Cont'd

**LDG WITH ABNORMAL L/G (Cont'd)**

 ● **if both MAIN L/G abnormal**

- PITCH ATTITUDE (at touch down) ..... NOT LESS THAN 6°

**AFTER TOUCH DOWN**

- ENG (all) and APU FIRE pb ..... PUSH

 ● **when A/C stopped**

- ENG (all) and APU AGENT ..... DISCH
- EVACUATION ..... INITIATE

*IF NOSE L/G abnormal, aft passengers doors should preferably not be used for evacuation.*

## LDG WITH ABNORMAL L/G

The procedure is intended for use when nose or main L/G fail to extend or/and lockdown following the application of L/G GRVTY EXTN procedure.

It is considered preferable to use all available gears locked down rather than carry out a belly landing.

Under these circumstances, a hard surface runway landing is recommended.

Full advantage should be taken of any foam spread on the runway

### PREPARATION

- CABIN CREW ..... NOTIFY  
*Notify the cabin crew of the nature of emergency encountered and state intention.*
- ⇒ Specify the available time.
- ATC ..... NOTIFY  
*Notify ATC of the nature of emergency encountered and state intention.*
- JETTISON ..... ON  
*Consider fuel reduction to safe minimum. This reduces VREF and as a consequence the load factor at impact and the energy to be dissipated.*
- OXYGEN CREW SUPPLY ..... OFF
- GPWS SYS ..... OFF  
*to avoid nuisance warning.*
- SEAT BELTS/NO SMOKING ..... ON
- COMMERCIAL ..... OFF
- CABIN and COCKPIT ..... PREPARE
  - loose equipment secured
  - survival equipment prepared
  - belts and shoulder harness locked
- if NOSE L/G abnormal
  - CG location (if possible) ..... AFT  
*• 10 PAUX from front to rear ~ + 2 %*
  - ⇒ T TANK FEED ..... ISOL
- if one MAIN L/G abnormal
  - FUEL IMBALANCE ..... CONSIDER  
*Reduce fuel on side of failed L/G by opening all X-FEED and by switching off the pumps on the non affected side.*
  - GROUND SPOILERS ..... DO NOT ARM  
*Spoilers must not be armed to keep full roll control.*



## LDG WITH ABNORMAL L/G (CONT'D)

### APPROACH

- L/G LEVER ..... CHECK DOWN
- L/G GRVTY EXTN ..... CHECK DOWN  
*Resetting of the free fall system with the L/G lever selected DOWN and one gear not locked down would result in extension of centre gear. This L/G configuration is not acceptable for landing.*
- CABIN REPORT ..... OBTAIN
- JETTISON ..... OFF  
*Note: Depress the EMER CANCEL pb when the L/G GEAR NOT DOWN warning occurs.*

### BEFORE LANDING

- RAM AIR ..... ON  
*to ensure full depressurisation of A/C before impact.*
- BRACE FOR IMPACT ..... ORDER

### JUST BEFORE TOUCH DOWN

- ENG MASTER (all) ..... OFF
- if NOSE L/G abnormal
  - NOSE ..... MAINTAIN UP  
*After touch down keep the nose off the runway by use of elevator.*
  - BRAKES (compatible with elevator efficiency) ... APPLY
- if one MAIN L/G abnormal
  - FAILURE SIDE WING ..... MAINTAIN UP  
*Use roll control as necessary to maintain the unsupported wing up as long as possible.*
  - DIRECTIONAL CONTROL ..... MAINTAIN  
*Use rudder and brakes to maintain runway axis as long as possible.*
- if both MAIN L/G abnormal
  - PITCH ATTITUDE (at touch down) . . NOT LESS THAN 6°  
*Pitch attitude at touch down must not be less than 6° to ensure that the tail section impacts first.*



## LDG WITH ABNORMAL L/G (CONT'D)

### AFTER TOUCH DOWN

- ENG (all) and APU FIRE pb ..... PUSH
- **when A/C stopped**
  - ALL ENG and APU AGENT ..... DISCH
  - EVACUATION ..... INITIATE
    - Announce through PA "PASSENGER EVACUATION EVACUATE THROUGH L or R DOORS" and press EVAC COMMAND pb.
    - Be aware that forward passengers door evacuation rates (if abnormal NOSE L/G) or aft passengers door evacuation rates (if abnormal MAIN L/G) are considerably reduced due to abnormal slide inclination.
    - Aft passengers doors should preferably not be used for evacuation if NOSE L/G abnormal.

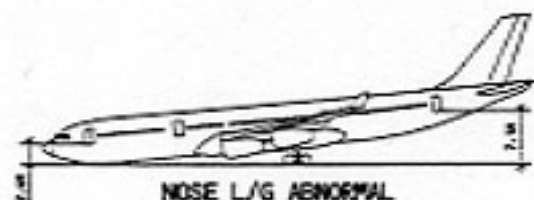

77CS-03-0232-006-A601AB



This photograph, taken the following morning, shows the aircraft after jacking and prior to moving. Note the runway centreline markings and aircraft heading. The runway had been repaired by the time this photograph was taken



LEFT MAIN GEAR JAMMED IN PARTLY EXTENDED POSITION



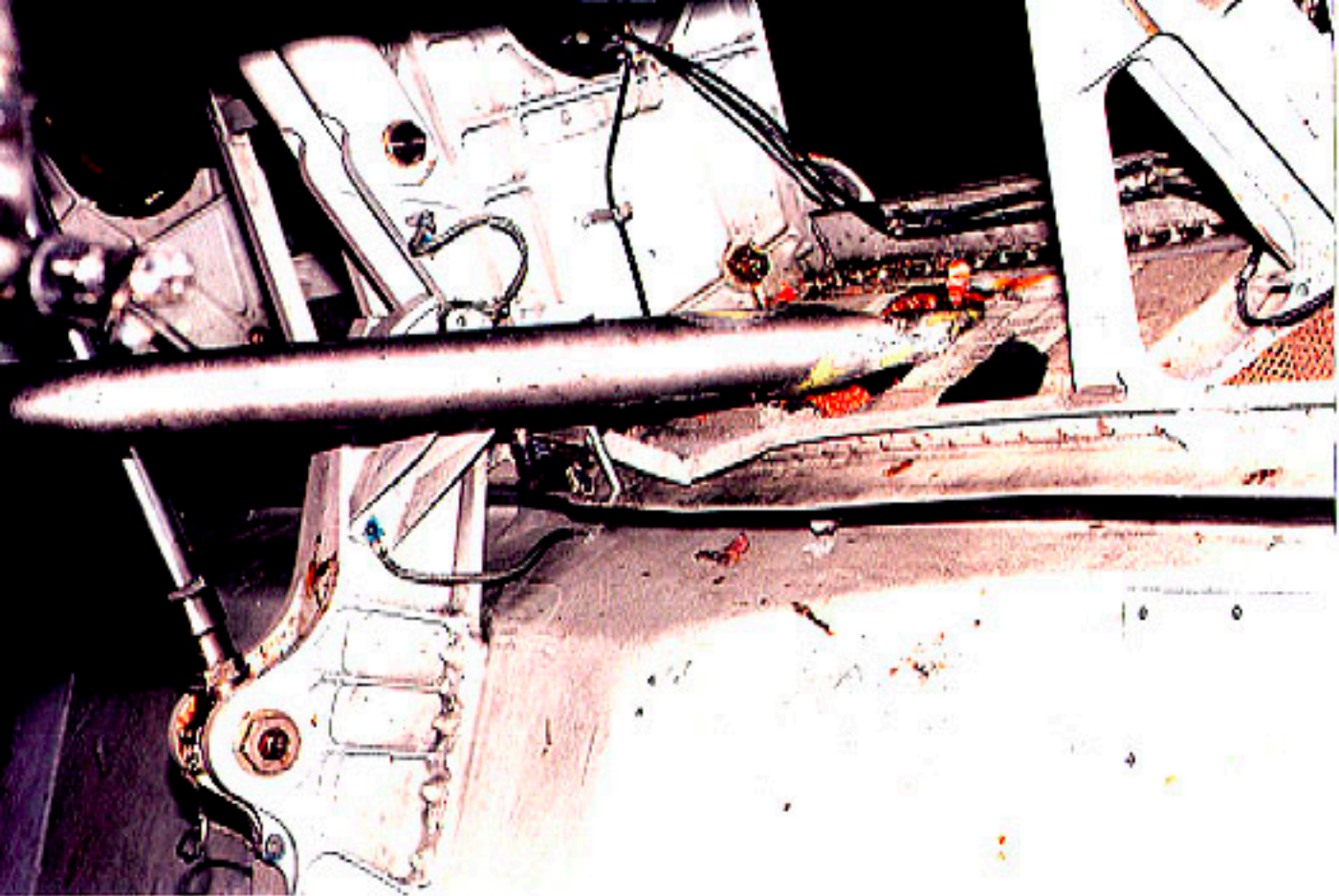

No. 6 BRAKE TORQUE ROD JAMMED IN KEEL BEAM STRUCTURE



The No. 6 torque pin recovered from the departure end of runway 24L at Los Angeles Airport

**Illustration not Available**

Fss.aero was unable to obtain permission from Jeppesen-Sanderson, Inc. to reproduce this copyrighted chart.

Please see the FAQ for easy work-arounds.

Jeppesen-Sanderson can be reached at:

[www.jeppesen.com](http://www.jeppesen.com)

55 Inverness Drive East  
Englewood, CO 80112-5498

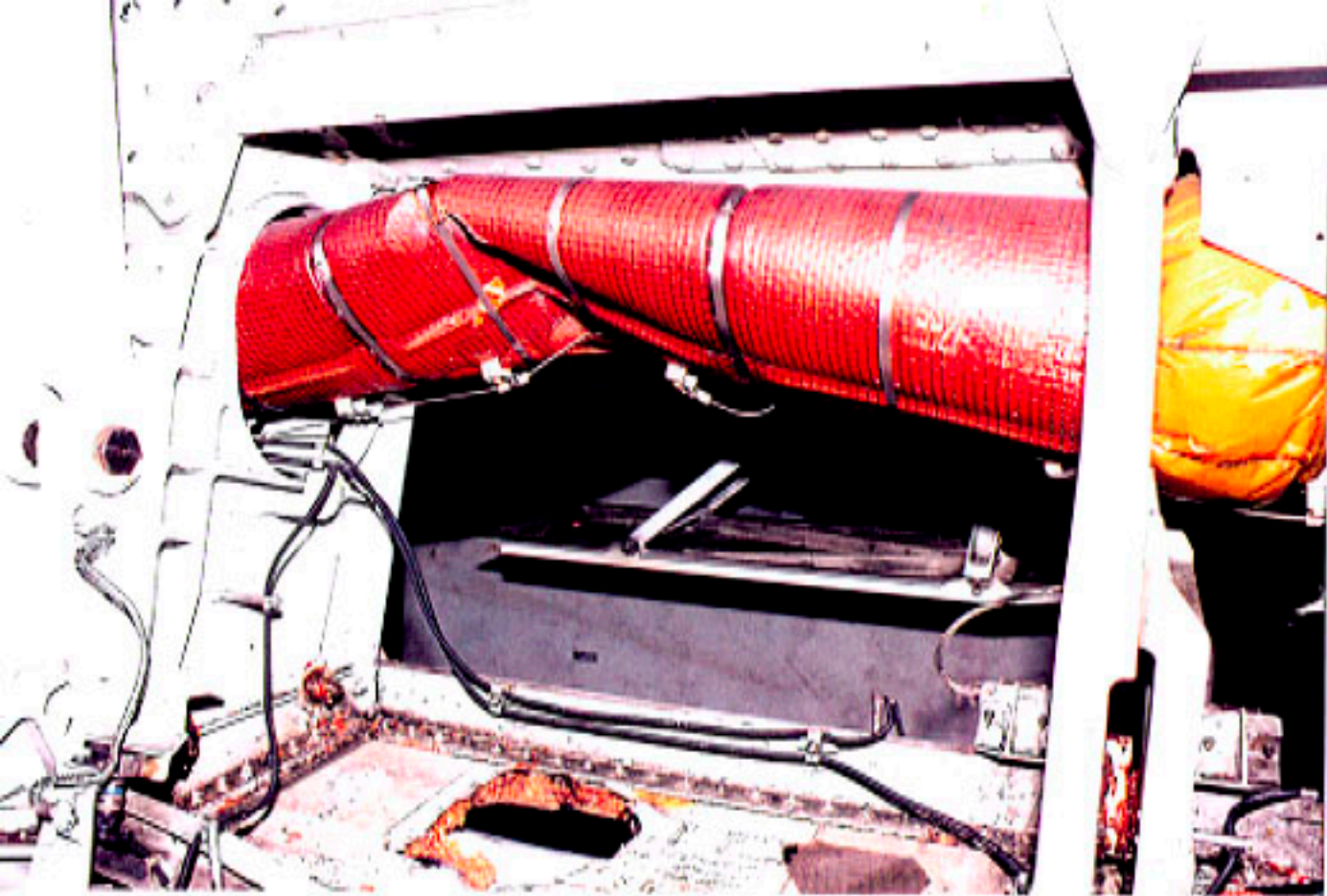

View of the damage to the keel beam area. Note the damage to the honeycomb panel and distortion of the nearer edge member at the bottom of the picture

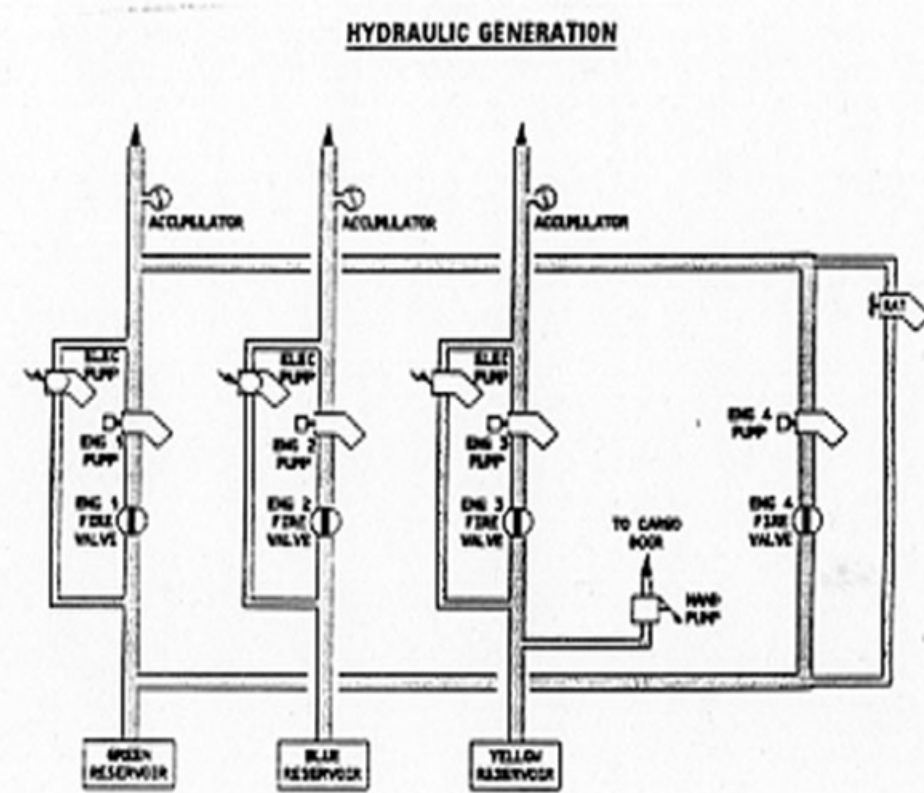
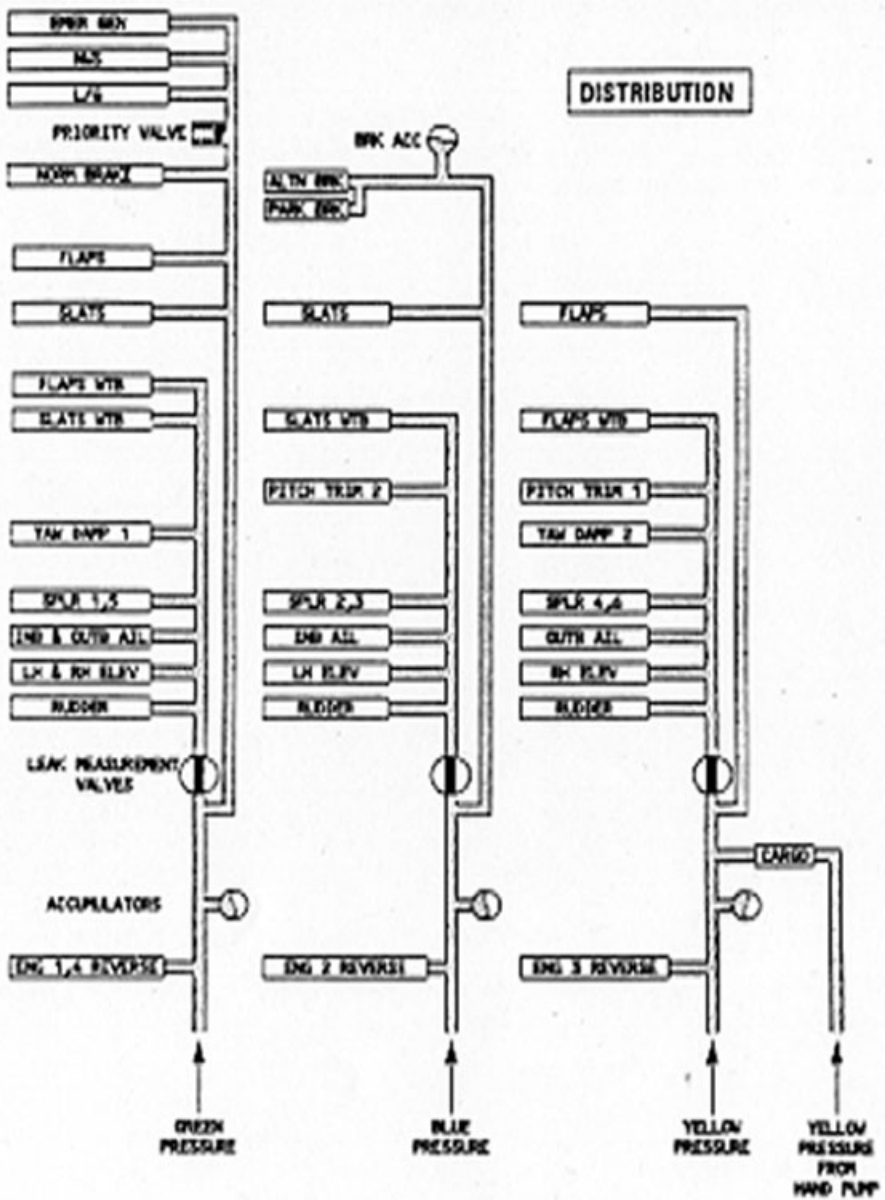

SCHEMATIC DIAGRAM OF THE  
A340 HYDRAULIC SYSTEM



# VIR – A340 G-VSKY landing incident

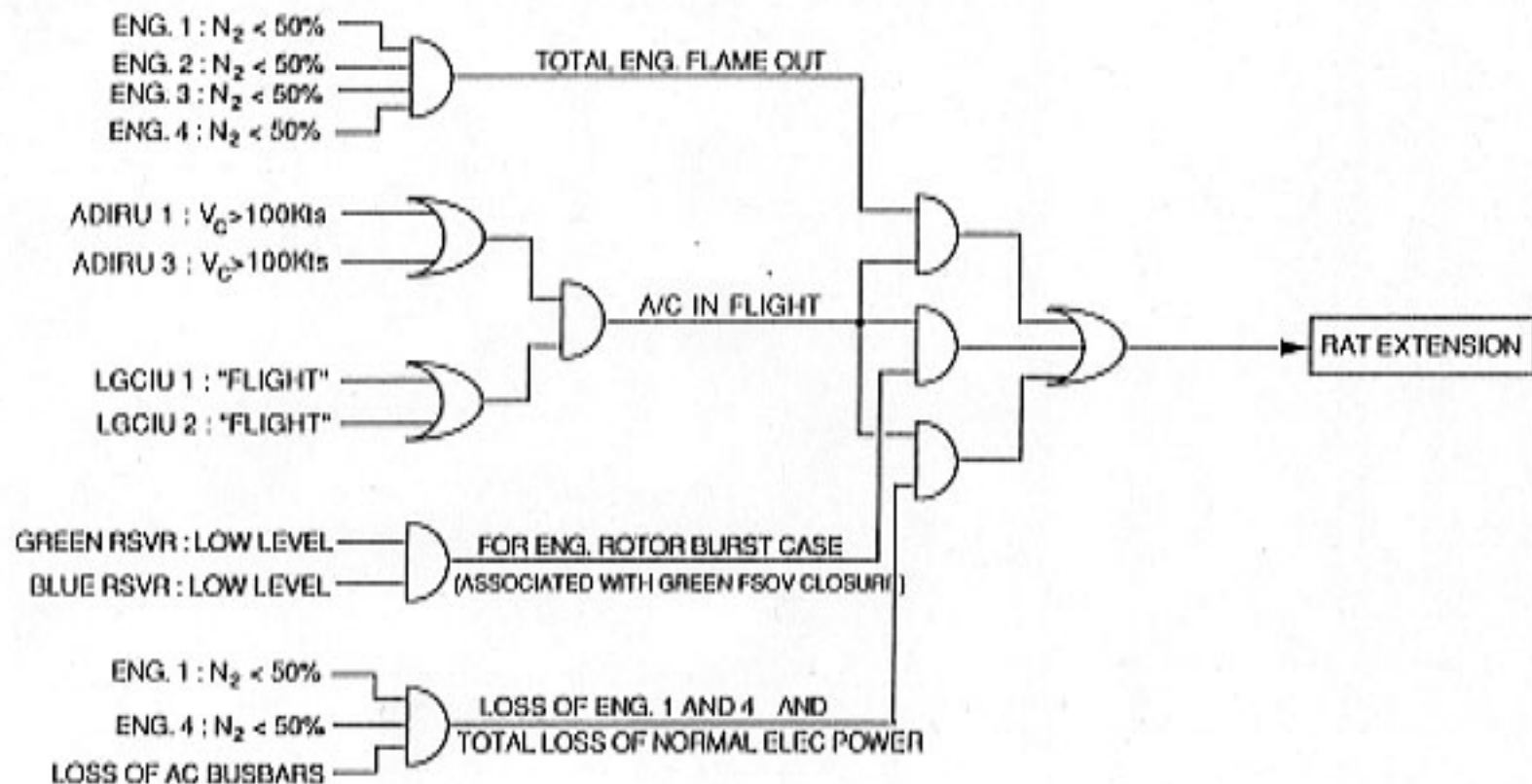

A340 RAT - AUTOMATIC DEPLOYMENT CONTROL (PRINCIPLE)

### Rate limitation on GREEN hydraulic surfaces

- The objective is to keep the GREEN hydraulic flow demand consistent with the RAT performance
- It is activated when:
  - RAT deployed and BLUE hydraulic low pressure
  - RAT deployed and YELLOW hydraulic low pressure
  - RAT deployed and ENG 1 and ENG 4 out

# VIR – A340 G-VSKY landing incident

---

## Rat Performance

*A/C slats extended*

VC	F/CTL limitations			Hyd. flow with internal leakage (l/mn)	Available RAT flow
	Pitch	Roll	Yaw (°/s)		
250 kts	20	17	10	79.4	97 l/mn (180 bar)
175 kts	20	17	10	79.4	80 l/mn (180 bar)
150 kts	20	15	10	75.3	76 l/mn (110 bar) 47 l/mn (180 bar)
140 kts	20	10	10	65.0	65 l/mn (110 bar) 40 l/mn (180 bar)
130 kts	14	7	7	48.7	49 l/mn (110 bar) 30 l/mn (180 bar)
125 kts	11	6	6	42.0	42 l/mn (110 bar) 26 l/mn (180 bar)



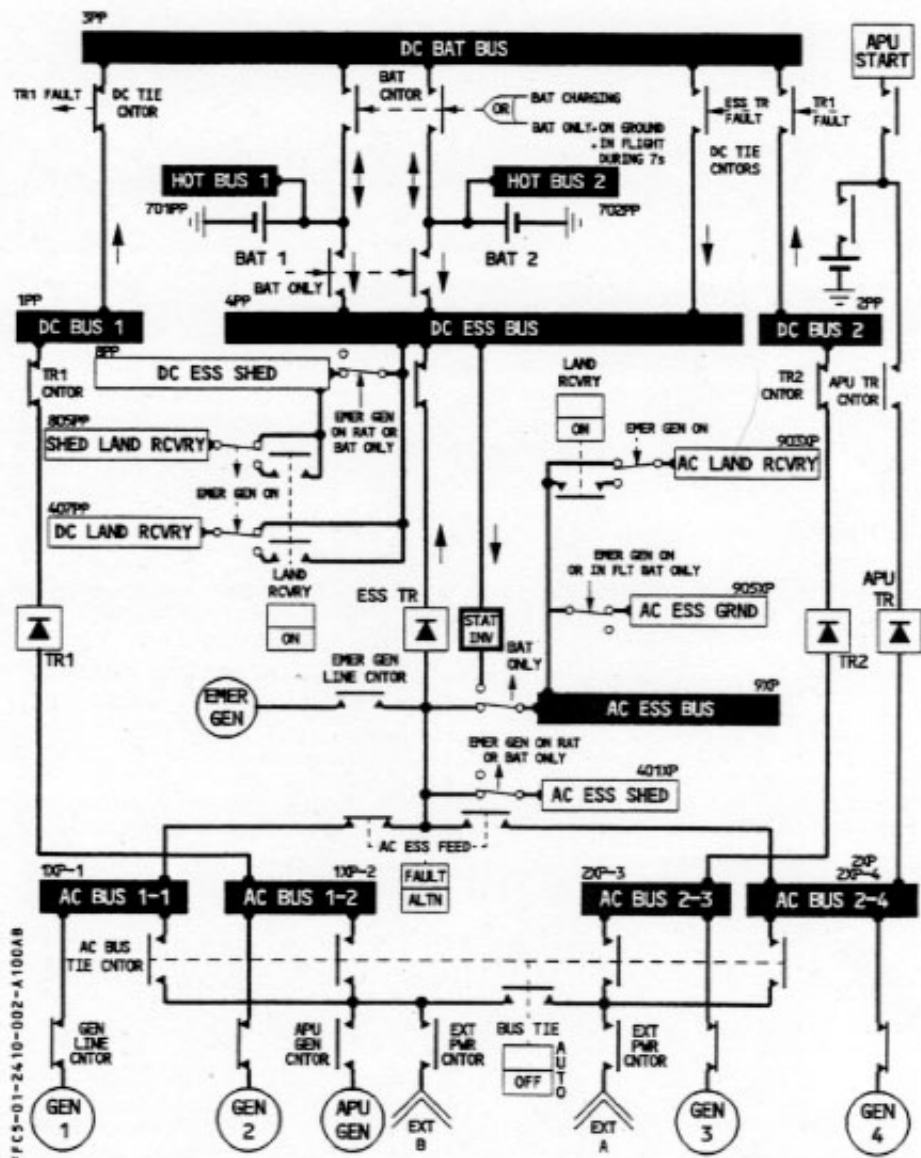

ELECTRICAL POWER SCHEMATIC DIAGRAM

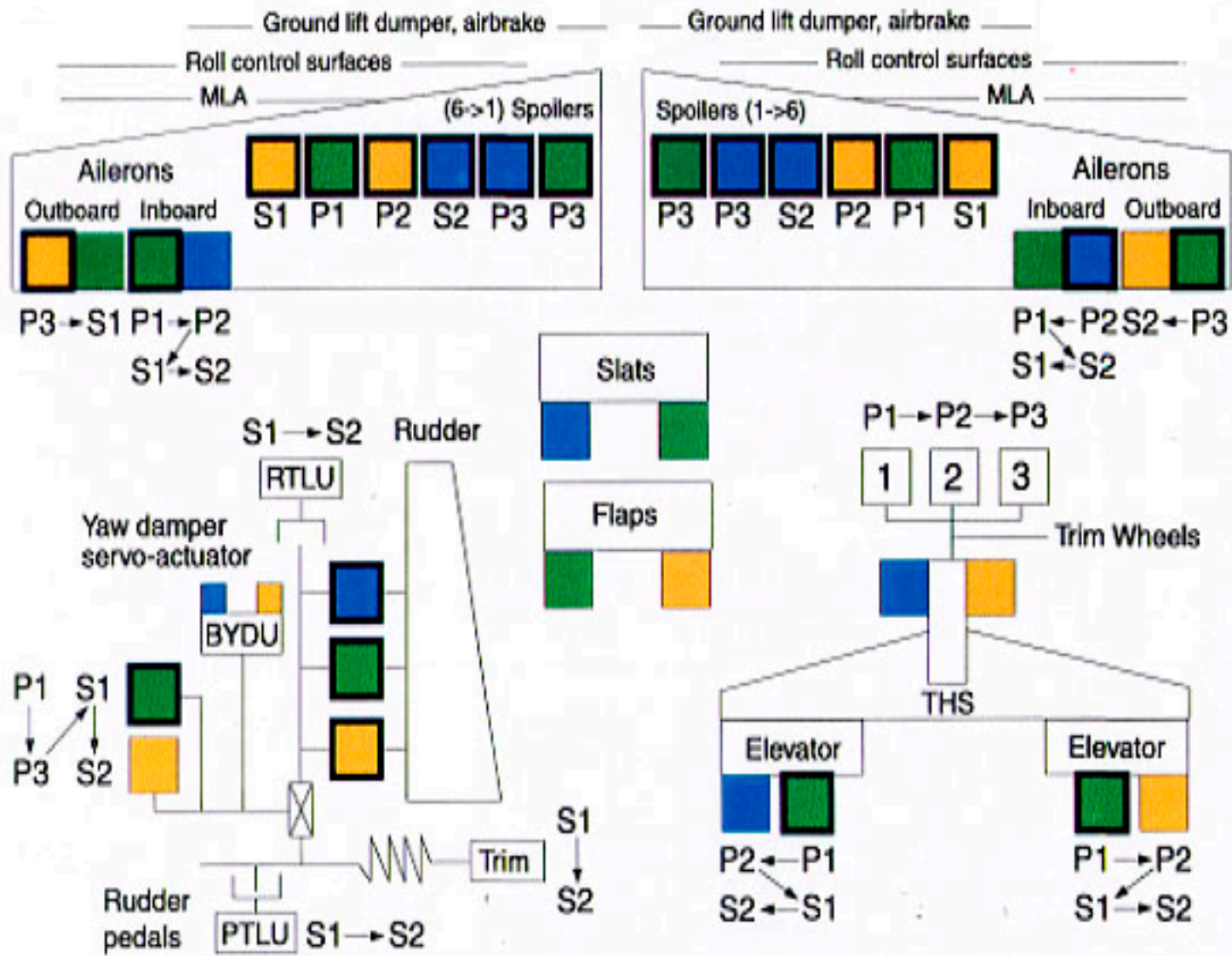

- Blue, Green, Yellow Hydraulic circuits
- P Primary computer
- S Secondary computer
- shaded area indicates priority of servo controls
- RTLU Rudder Travel Limitation Unit
- PTLU Pedal Travel Limitation Unit
- BYDU Back up Yaw Damper Unit
- MLA Manoeuvre Load Alleviation

PRIM & SEC COMPUTER COMMAND PATHS AND FLYING CONTROL HYDRAULIC SUPPLIES

The brake is mounted on a splined axle sleeve that extends the length of the axle.

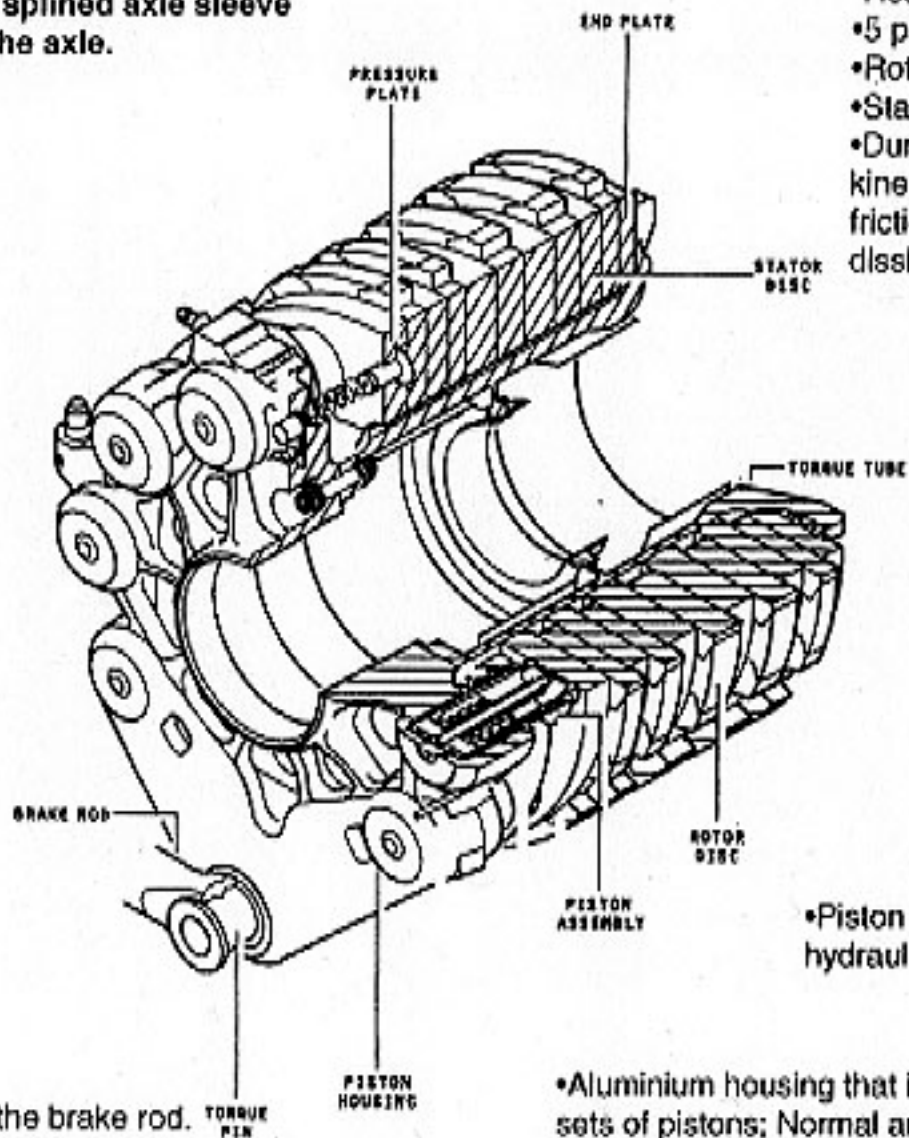

**Heat Pack:-**

- 5 pair carbon heat pack
- Rotors are engaged to the wheel
- Stators are engaged to the torque tube.
- During braking the heat pack transfers kinetic energy to heat energy due to the friction at each interface and subsequently dissipates the heat energy to the surrounding structure

- Steel torque tube that holds the stator discs stable in the heat pack.
- Transmits the brake torque from the stator discs to the piston housing.
- Leg supports tube on axle sleeve.

- Piston assemblies compress heat pack when hydraulic pressure is supplied.

- Connects the piston housing to the brake rod.
- Transmits all torque generated brake loads.

- Aluminium housing that incorporates two independent sets of pistons; Normal and Alternate.
- A bore in the torque pin lug is bushed to house the torque pin.

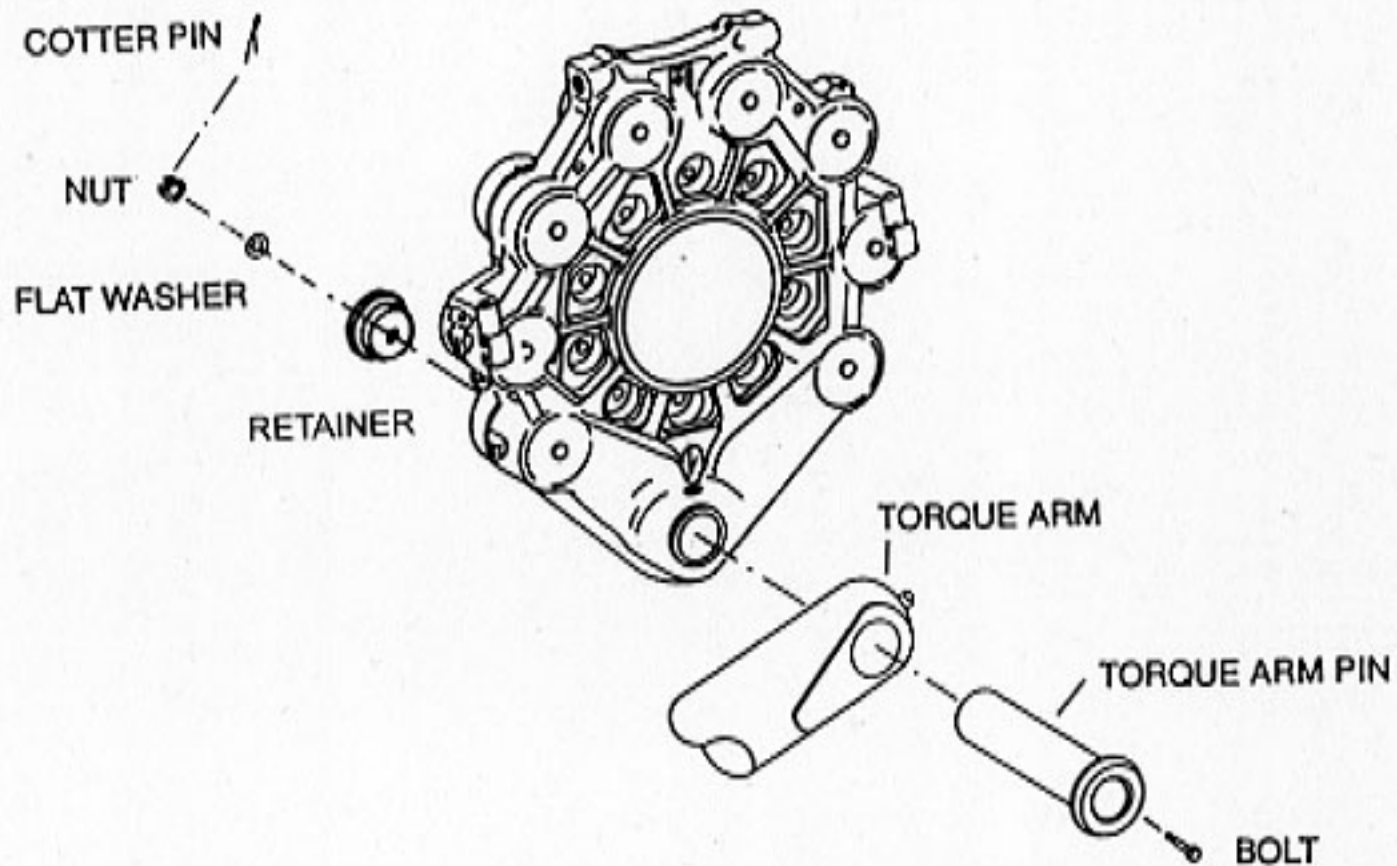

PISTON HOUSING AND TORQUE PIN ASSEMBLY FITTED TO G-VSKY

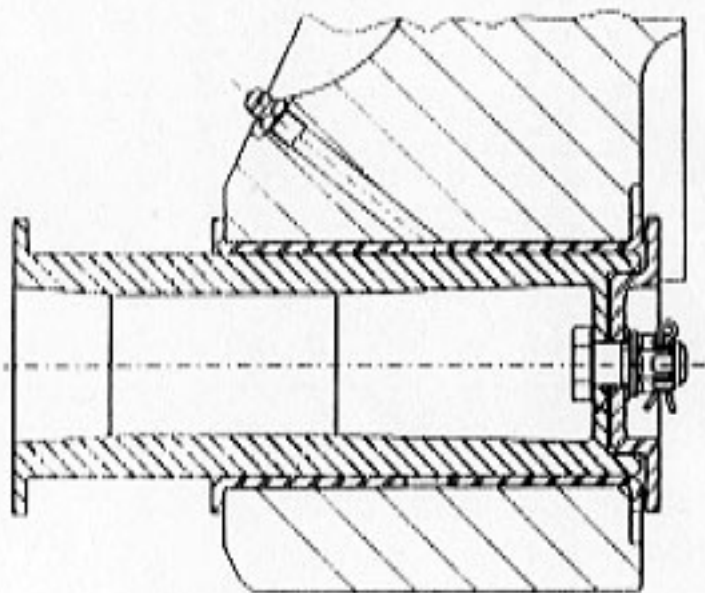

IGW pin assembly drawn. EIS standard as fitted to G-VSKY was similar except for a reduced wall thickness within the pin, and the use of smaller 1/4 inch diameter fasteners.

EIS (ENTRY INTO SERVICE) AND IGW  
(INCREASED GROSS WEIGHT) TORQUE PINS

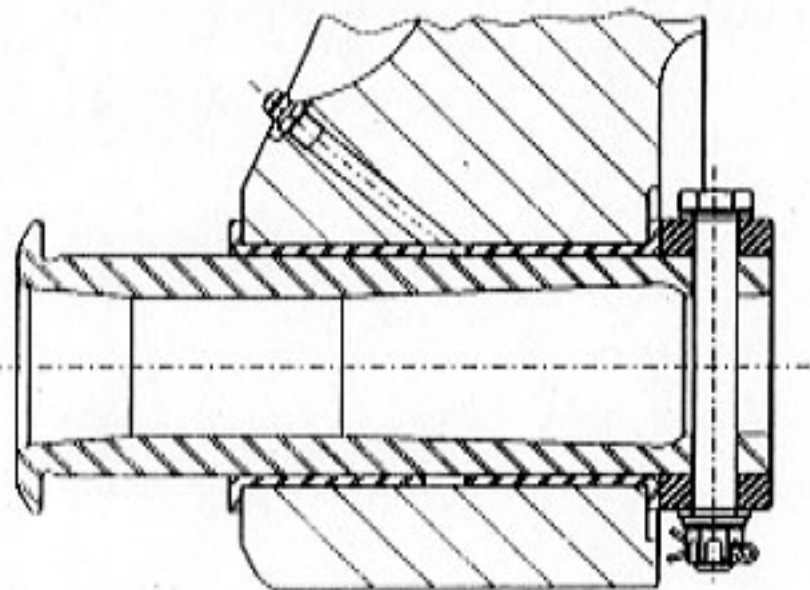

REDESIGNED PIN ASSEMBLY EMPLOYING STRONGER PIN  
AND COLLAR TYPE RETENTION DEVICE

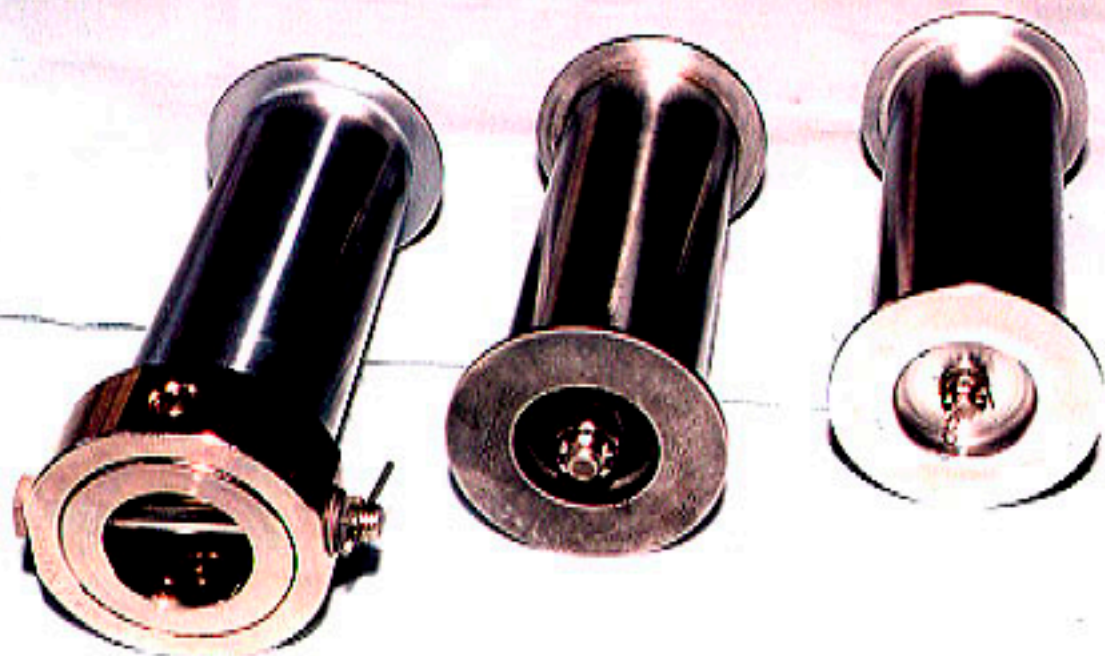

### TORQUE PIN ASSEMBLIES

LEFT  
CENTRE  
RIGHT

THE REDESIGNED PIN, COLLAR AND RETAINING PARTS,  
THE INCREASED GROSS WEIGHT STANDARD  
THE ENTRY INTO SERVICE STANDARD

APPENDIX 14  
PAGE 3

# FDR Data - Take off from Los Angeles

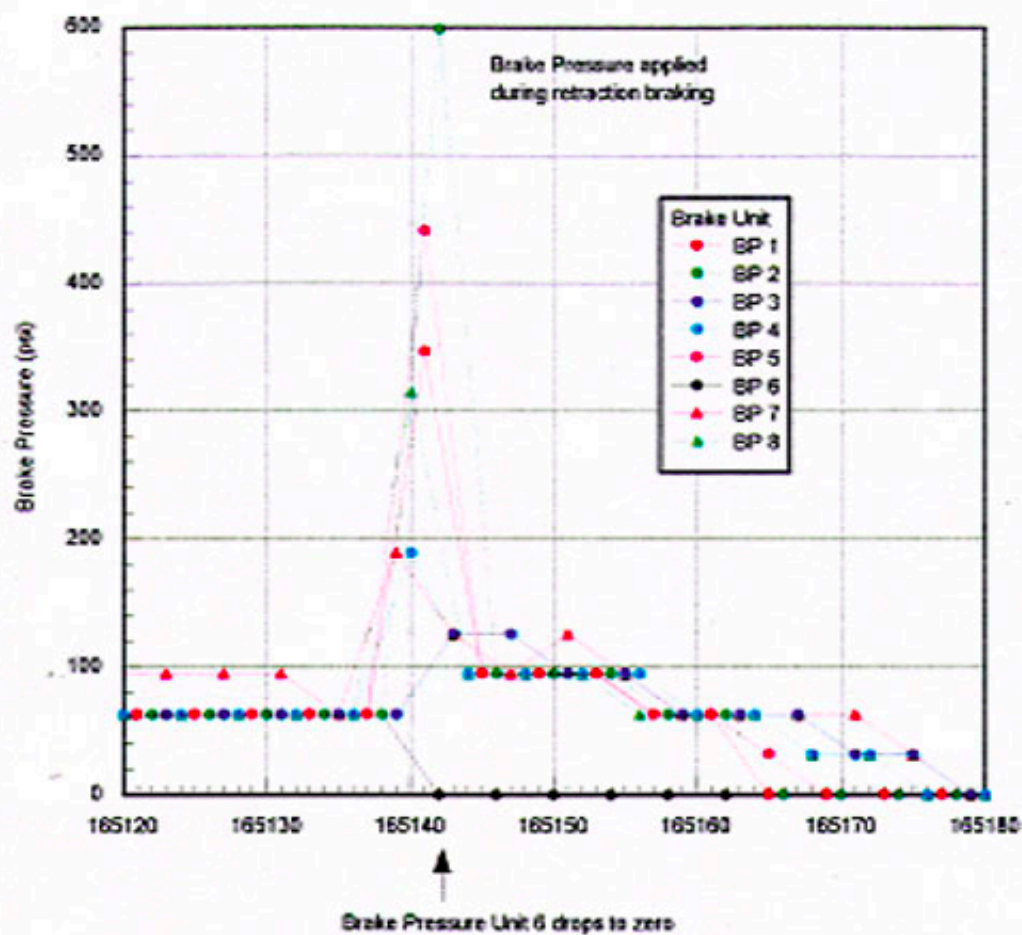
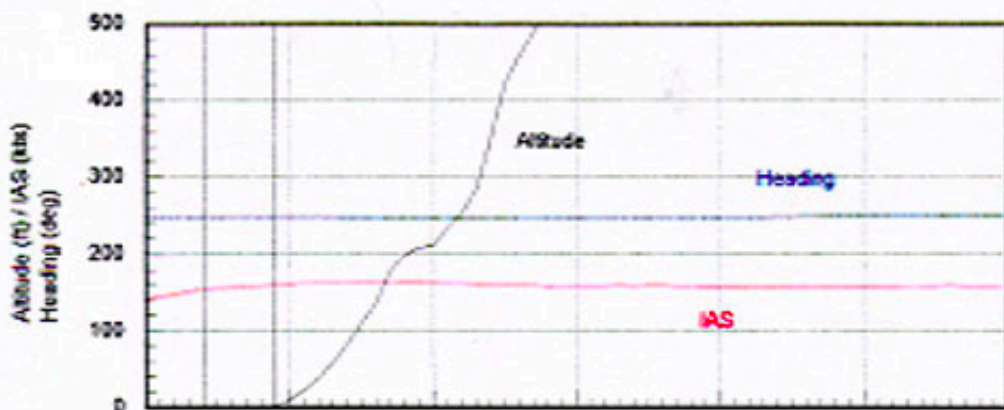

Landing Gear Selected Up

Landing Gear Up and Locked

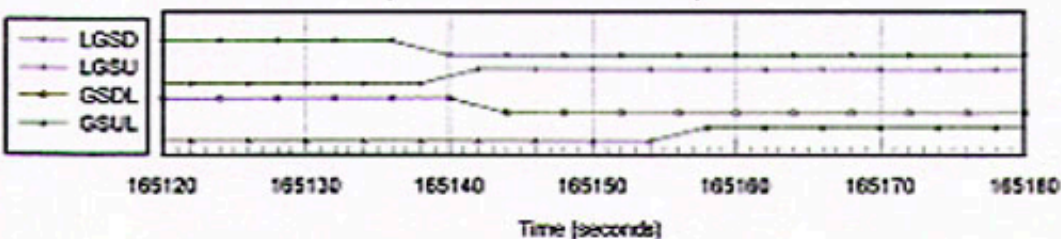



# FDR Data - Initial Approach at Heathrow

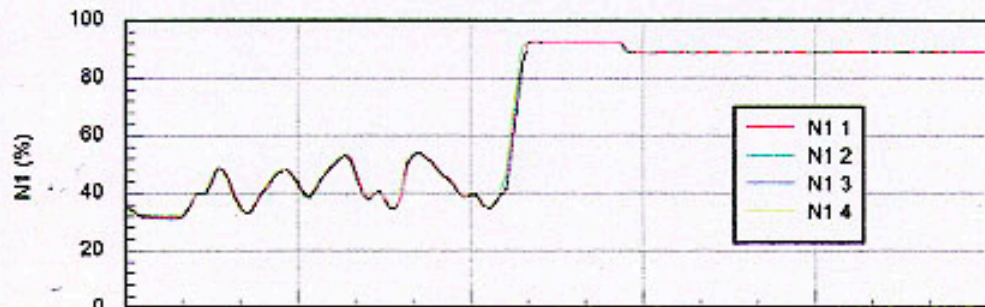
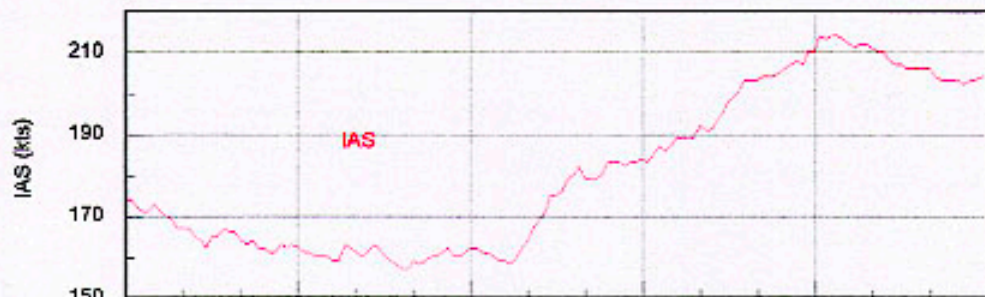
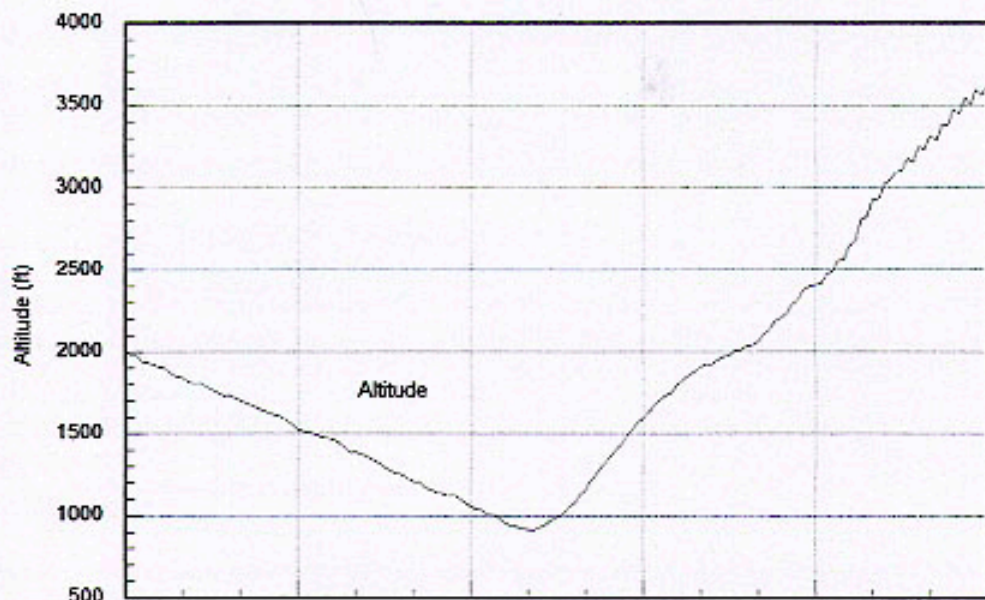

Landing Gear Selected Down      Landing Gear Selected Up      LGCIU reset      Emergency free-fall Gear Selection

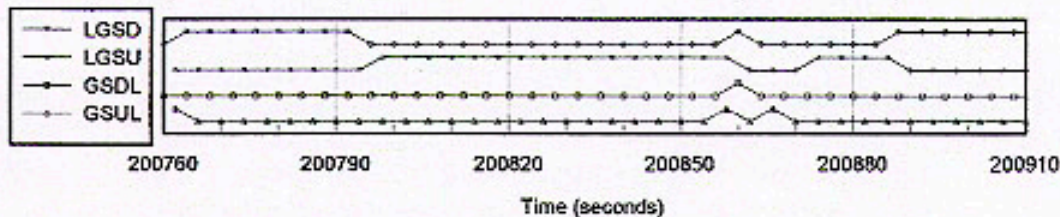
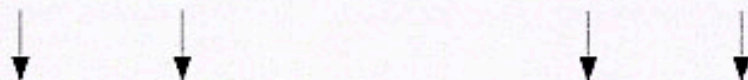

# FDR data - Approach and Landing at Heathrow

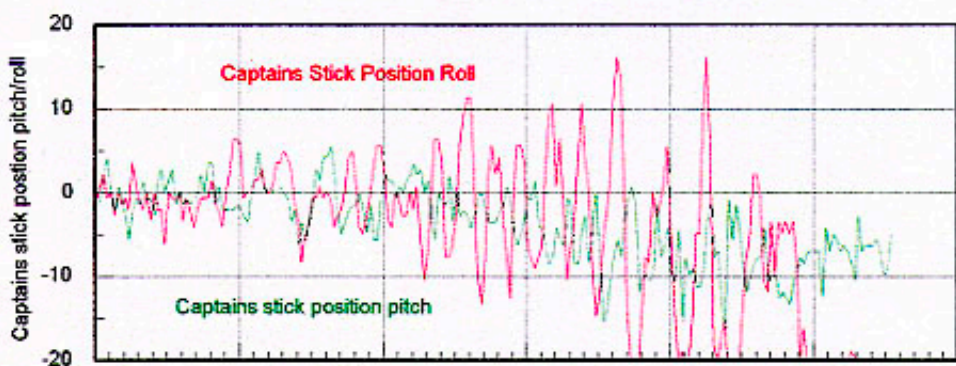
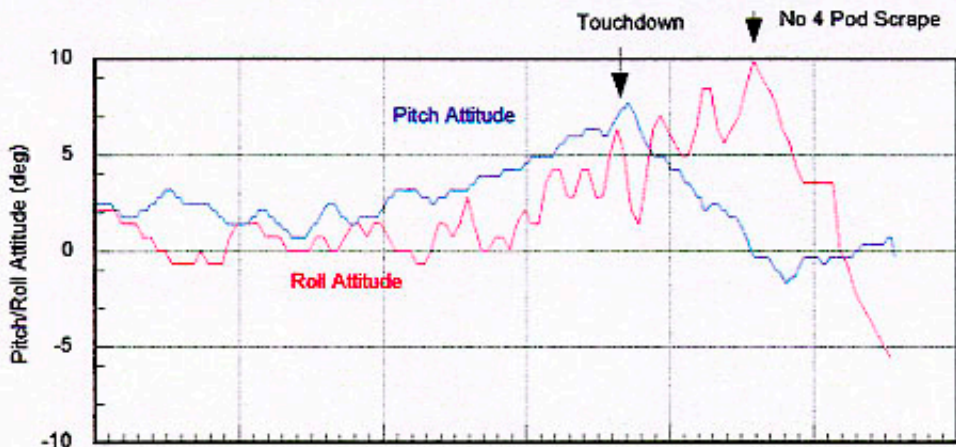
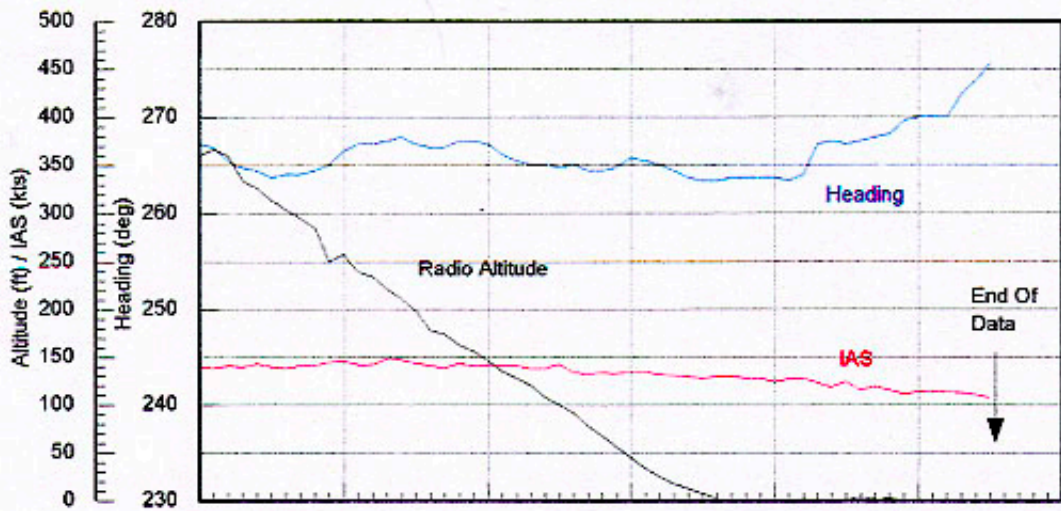

Nose Squat Switch ■ ■

Right Main Squat Switch ■

- Control Law**
- DIRECT LAW
  - ALT LAW
  - NORM LAW
  - FCSC1CL
  - FCSC1CL
  - FCPC3CL
  - FCPC2CL
  - FCPC1CL

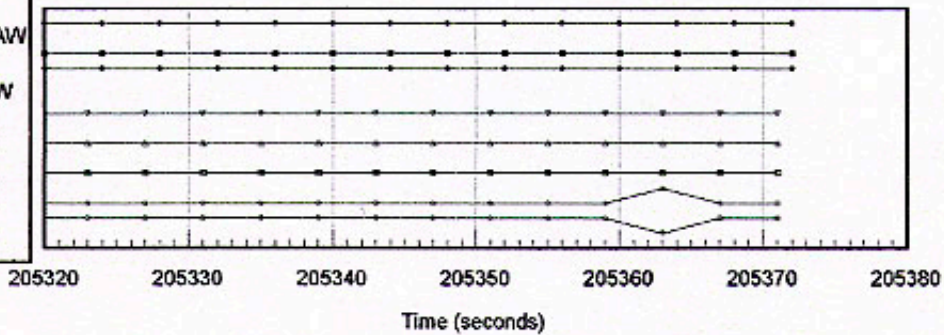

# FDR data - Approach and Landing at Heathrow

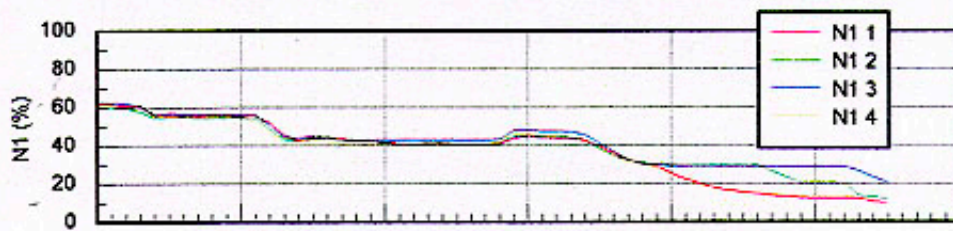
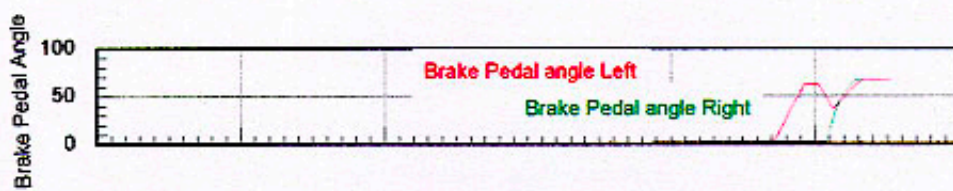
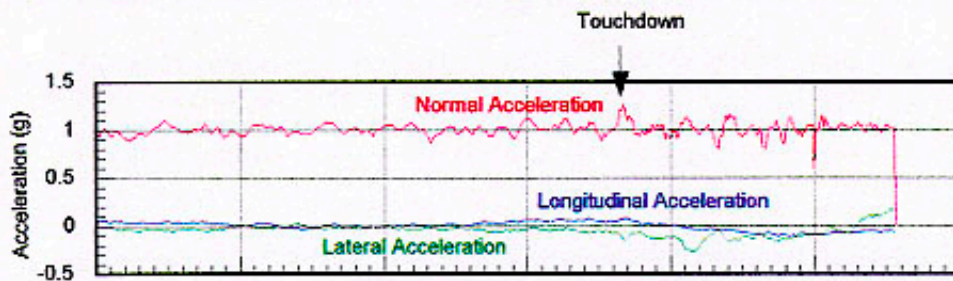
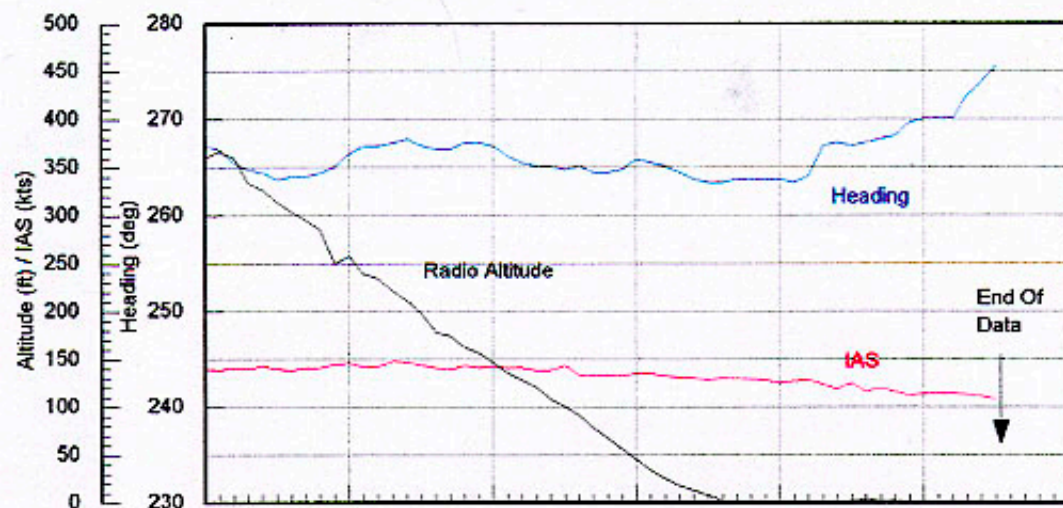

Nose Squat Switch

Right Main Squat Switch

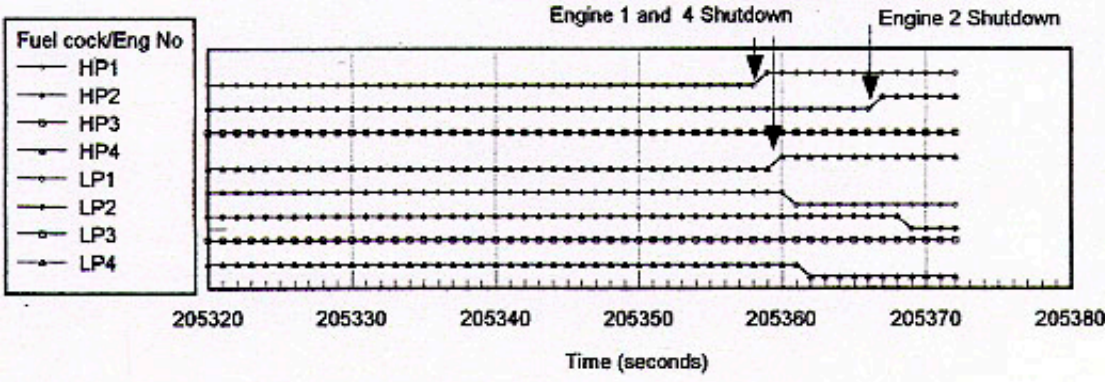

## Airbus A340-311, G-VSKY: Appendix 16

**Aircraft Accident Report No: 4/2000 (EW/C97/11/1)**

**Report on the accident to Airbus A340-311, G-VSKY at London Heathrow Airport on 5 November 1997**

### APPENDIX 16

UTC	FDR Time to End	FDR Indications	PFR CMC System Fault/Operation  (Only relevant warnings included)
0502		<b>Recorded Aircraft Weight 233540 Kg</b>	ENGINE START
0509	11:10:40	Gear selected 14 seconds after take off from LAX  No brake pressure recorded on Brake 6 on retraction braking	L/G DOORS NOT CLOSED  Warning triggered if landing gear doors are not closed within 30 seconds  SNSR BRK TEMP (6GW2)  Fault from the brake temp sensor on Brake 6
0510			L/G SYS DISAGREE  Centre Landing Gear uplock sensors disagreement for more than 2s but less than 5s
1504	1:16:54	Initial Approach  Gear Selected Down  Height 1973 ft, CAS 172 kts	LANDING GEAR NOT DOWN LOCKED triggered when all landing gear not locked down  SERVOVALVE-NORM BRK (12GG1) no pressure seen at Brake

			6 during pre-land test  LANDING GEAR NOT UNLOCKED triggered after gear up selection - brake rod jam prevented gear from unlocking or downlocking
	1:16:18	Gear Selected Up  Height 1400 ft, CAS 163 kts	
	1:15:46	Go-around min altitude 900 ft  <b>Recorded Aircraft Weight 166886 Kg</b>	
1505	1:15:18	LGCIU system reset by crew	L/G LGCIU 1+2 FAULT
1506		Alt 2600 ft, CAS 190 kts	L/G LGCIU 2 FAULT  generated by system resets
<b>UTC</b>	<b>FDR Time to End</b>	<b>FDR Indications</b>	<b>PFR CMC System Fault/Operation</b>  (Only relevant warnings included)
1507	1:14:46	Alt 4000 ft, CAS 212 kts  Gear selected down - emergency system lowering	LGCIU 1 FAULT  SELCTOR VALVE - NWS  L/G FREE FALL  BSCU fault - loss of Nose Wheel Steering as no hydraulic pressure available. Hydraulic pressure is supplied by Nose Landing Gear doors closed Hydraulic line. Doors not closed after gear free fall
	1:08:46	Gear Selected up  Aircraft entered holding pattern at Alt 8000 ft, 190-200 kts	
1510			PROX SNSRS  LGCIU detects disagreement between status of LH gear doors

1517	1:03:26	LGCIU system reset by crew	LGCIU 2 (05GA2) BUS 2/ LGCIU 1 (05GA1)
1520	59:49	LGCIU system reset by crew	
	59:03	Gear selected down	
	56:50	Gear selected up	
	54:17	LGCIU system reset by crew	
1528			PROX SNSRS LGCIU detects disagreement between status of RH gear doors
	51:31	LGCIU system reset by crew	
	45:54	Gear selected down	
1535		<b>Recorded Aircraft Weight 162727 Kg</b>	
1538			BSCU CH 1 FAULT - no relevance to brake rod disconnect. Power interrupt with steering inactive suspected
	42:20	Gear selected up	
<b>UTC</b>	<b>FDR Time to End</b>	<b>FDR Indications</b>	<b>PFR CMC System Fault/Operation</b>  (Only relevant warnings included)
	26:18	Gear selected down	
	20:03  19:38	Fly past of Tower  Minimum Height 220ft, 155 kts  <b>Recorded Aircraft Weight 162052 Kg</b>  Power increased to Go-around	
1601			FUEL L WING TK LO LVL  FUEL L+ R WING TK LO LVL

			Fuel Low Level Warnings
	15:20	Aircraft performed steep turn to right up to 50° Roll right/ 1.46 Normal G  Alt 2000ft, 160 kts	
1605		<b>Recorded Aircraft Weight 158946 Kg</b>	FUEL L+ R CTR TK LO PR  Fuel Low Pressure Warning
1607			FUEL R CTR PUMP LO PR  Fuel Pump Low Pressure Warning
	10:10	Gear selected up  Level at Alt 3500ft, 160 kts  Aircraft orbit to right	
	9:02	Alt 3500 ft 156 kts  Gear selected down - emergency system lowering	
1615			FUEL PUMPS 2+STBY LO PR  FUEL PUMPS 3+STBY LO PR  Fuel Pumps Low Pressure Warning
<b>UTC</b>	<b>FDR Time to End</b>	<b>FDR Indications</b>	<b>PFR CMC System Fault/Operation</b>  (Only relevant warnings included)
	3:30	Final approach	
	19s	Touchdown G 1.262  Pitch Attitude 7.4°, Roll Attitude +4.9° RWD  129 kts CAS, Heading 264°  RH Squat compressed	
1620	18s  17s	Engine 1 shutdown (from HP fuel Valve Indication)  Engine 4 shutdown	ENG 1 SHUT DOWN  ENG 4 SHUT DOWN

	10s	<p>Pitch 1.1°, Roll 9.8° RWD</p> <p>120 kts CAS, Heading 268°</p> <p>Engine 4 pod scrape</p> <p>Engine 2 shutdown (from HP Cock Indication)</p>	
	8s	<p>Indication of Nose Squat Switch Compressed for one second</p> <p>Pitch -1.76°, Roll 6.32° RWD,</p> <p>115 kts CAS, Heading 268°</p>	
	4s	<p>Engine 3 shutdown (from HP Cock Indication)</p>	
	3s	<p>Pitch 0.35°, Roll -2.81° LWD</p> <p>110kts CAS, Heading 272°</p> <p>Nose Landing gear compressed</p> <p>Indication of brake pedal angle deflection.</p>	
	0s	<p>End of recording</p> <p>Pitch 0.35°, Roll -4.21° LWD</p> <p>107kts CAS, Heading 276°</p> <p>No hydraulic low pressure discretes showing hydraulic systems still pressurised.</p> <p>Flight Control Computer 1 discrete switched to FCC2 (PRIM 1 not operative)</p> <p><b>Recorded Aircraft Weight 157992 Kg</b></p>	



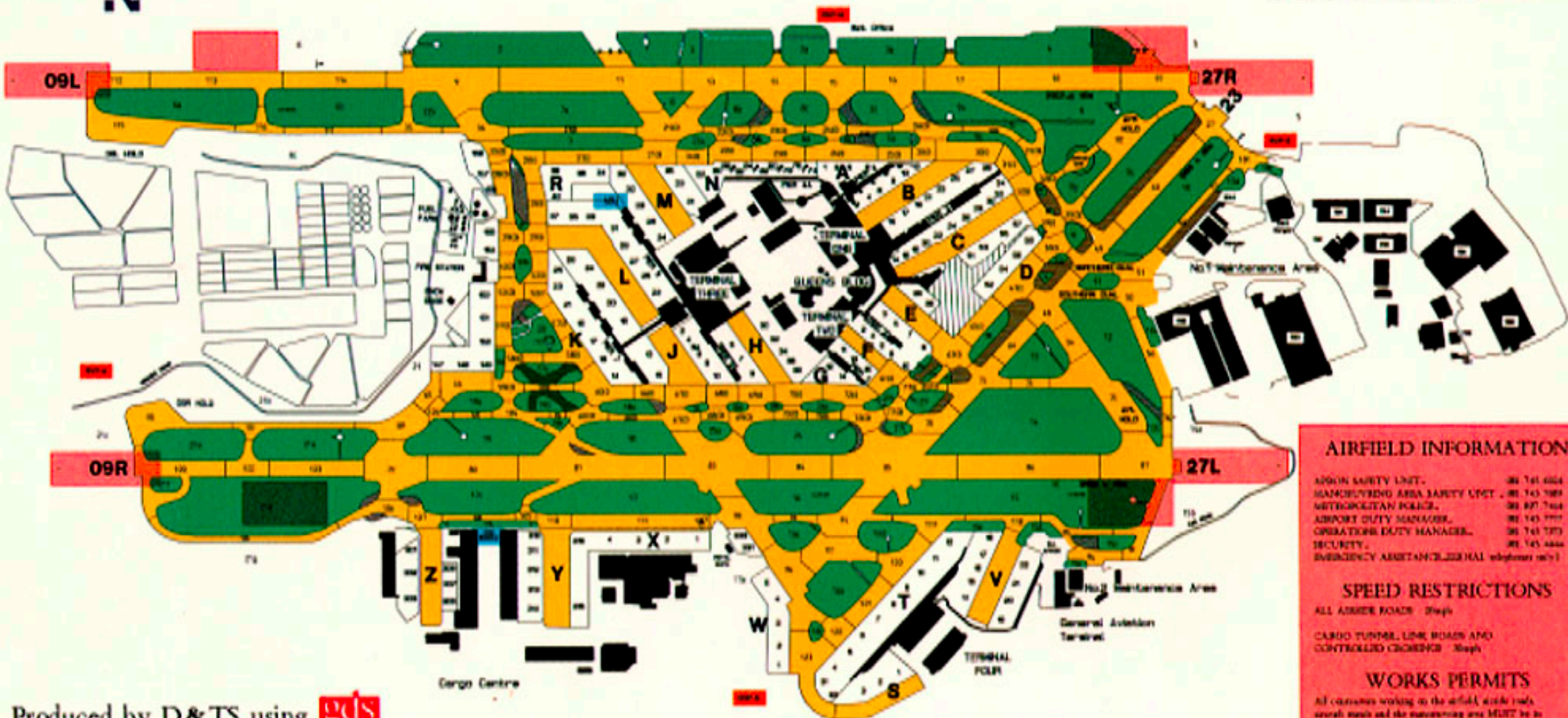

#### AIRFIELD INFORMATION

ADCON SAFETY UNIT	00 741 4024 7300
MANCHESTER AREA SAFETY UNIT	00 743 7089 3429
METROPOLITAN POLICE	00 897 7004
AIRPORT DUTY MANAGER	00 743 7777
OPERATIONS DUTY MANAGER	00 743 7370
SECURITY	00 743 4444
EMERGENCY ASSISTANCE/CELLAR	whenever on/1

#### SPEED RESTRICTIONS

ALL AIRSIDE ROADS 30mph

CARGO TUNNEL, LOW ROADS AND  
CONTROLLED CROSSINGS 20mph

#### WORKS PERMITS

All contractors working on the airfield, inside roads,  
sewerage mains and the manufacturing area MUST be in  
possession of a valid works permit.

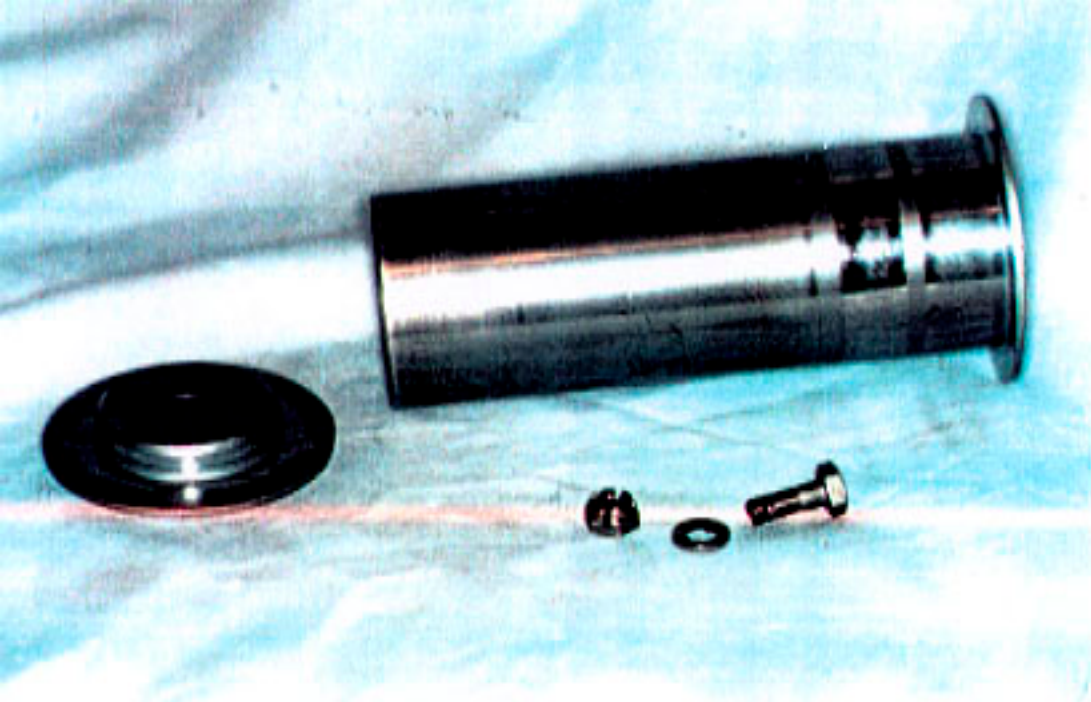

Pin, retainer and fasteners removed from No. 5 position,  
adjacent to missing parts at No 6 brake position.

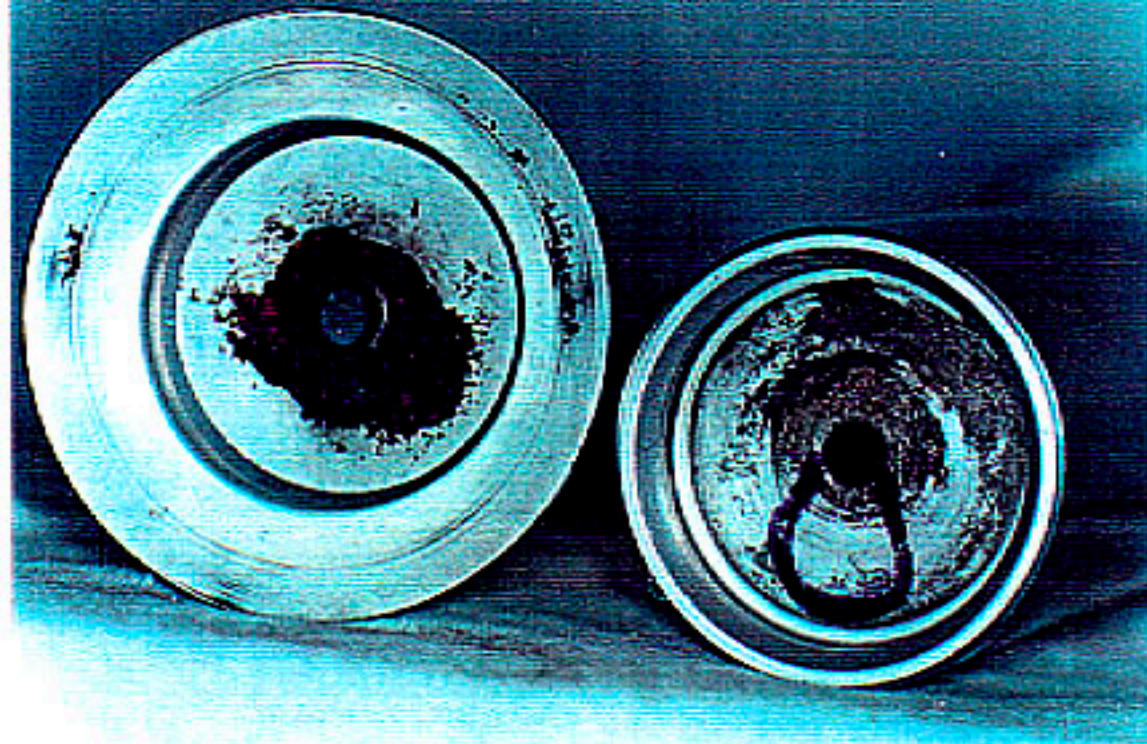

Plate A1

X1.24

View on the outer end of the pin and the inner end of the end cap from the No. 5 position on Virgin A340 Airbus registration G-VAEL showing extensive interface corrosion. The position of the radial crack is marked in black ink.

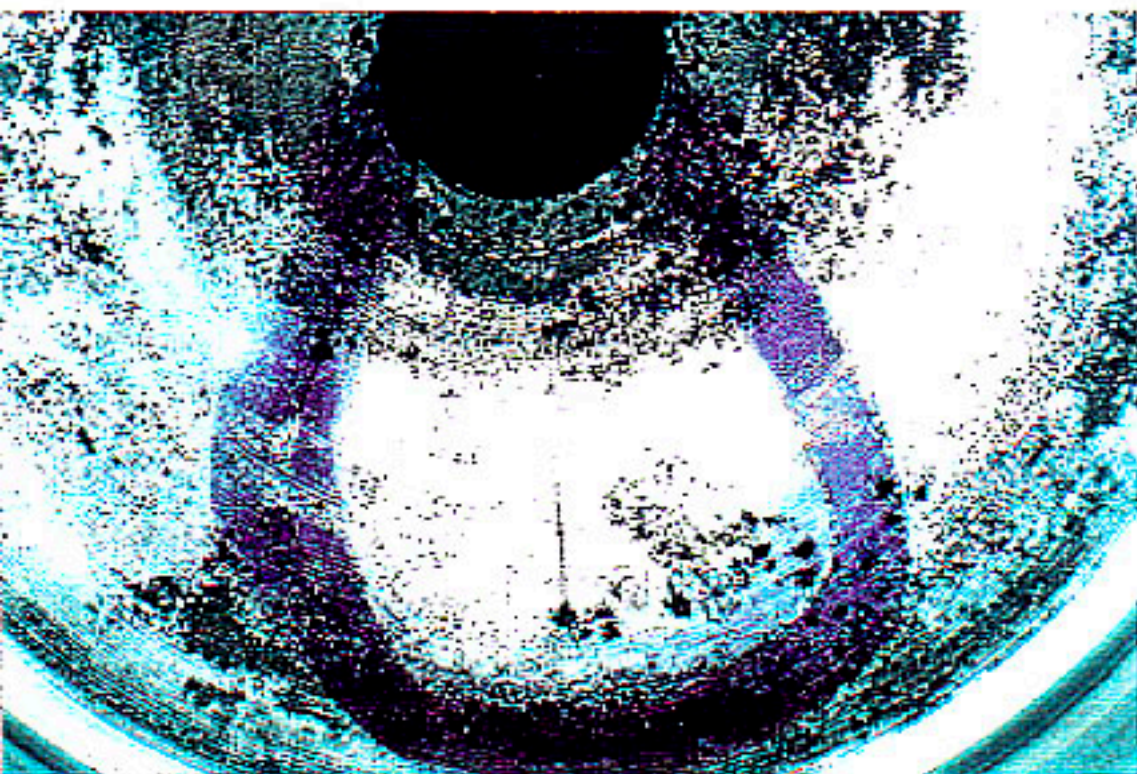

Plate A2

X6.43

Close up of the radial crack marked on Plate 1.

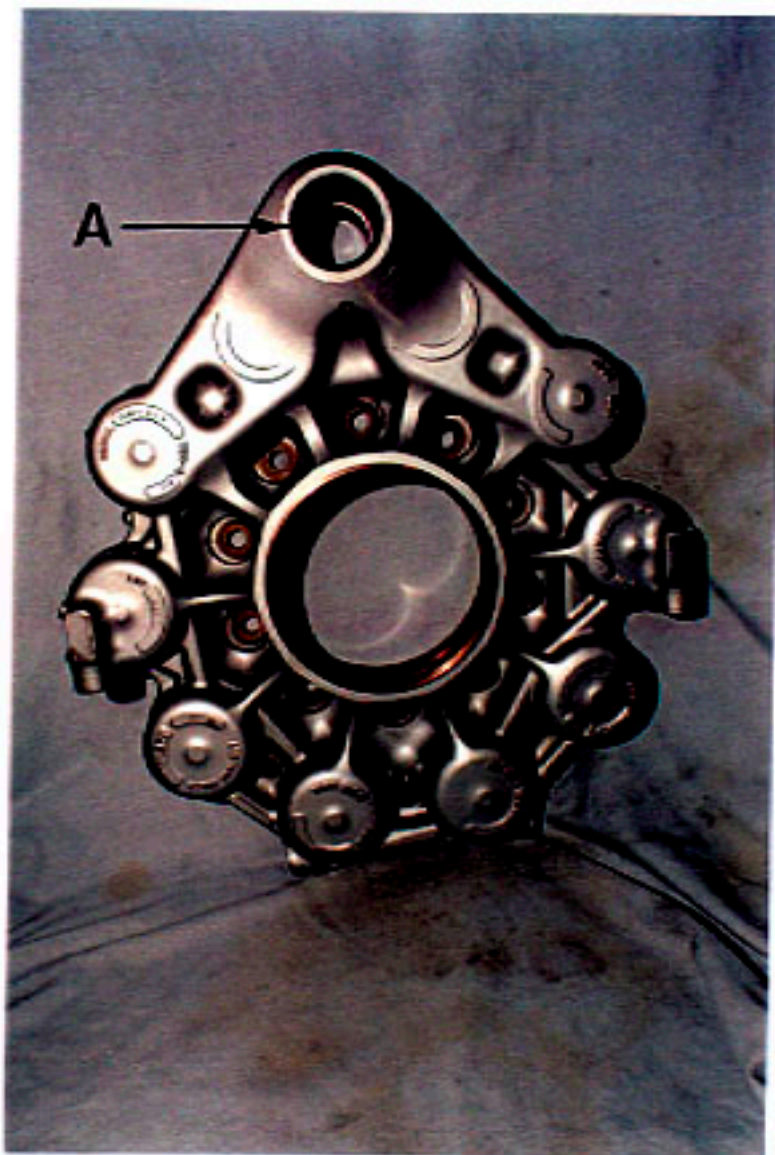

Plate 1

X0.17

Brake plate reported to be from the position on the left hand main undercarriage on Virgin Airbus G-VSKY from which the brake reaction rod became detached. The Plate was identified Part 5010218-1 ILM, SUBASSY 5010219-1, Serial No. SEP91-0039, TSO-0 26c, AB80-USA, TYPE IVBQ FORG 5010169.



Plate 2

X1.48



Plate 3

X1.48

Two views on the bush from position A on Plate 1. The pattern of the debris and marking conforms to the general pattern of the marking within the hole shown on Plates 4 & 5. The marking in the hole is positioned where arrowed on Plate 1.

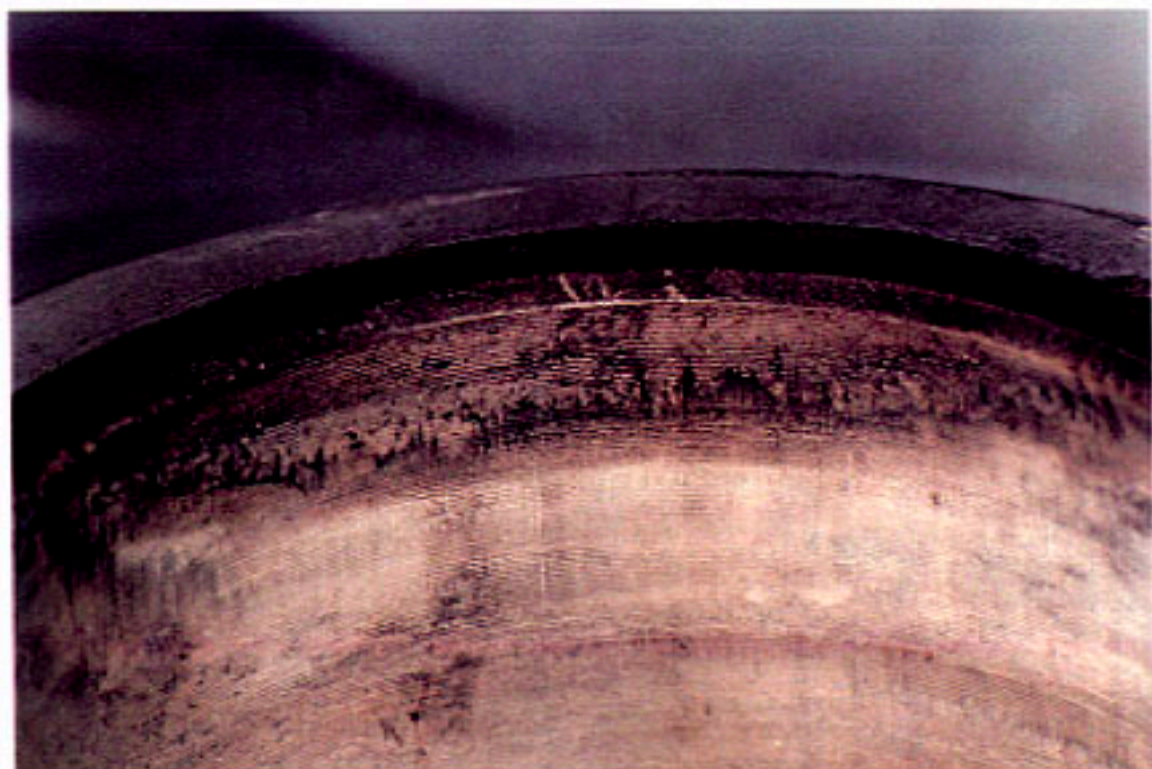

Plate 4

X2.63

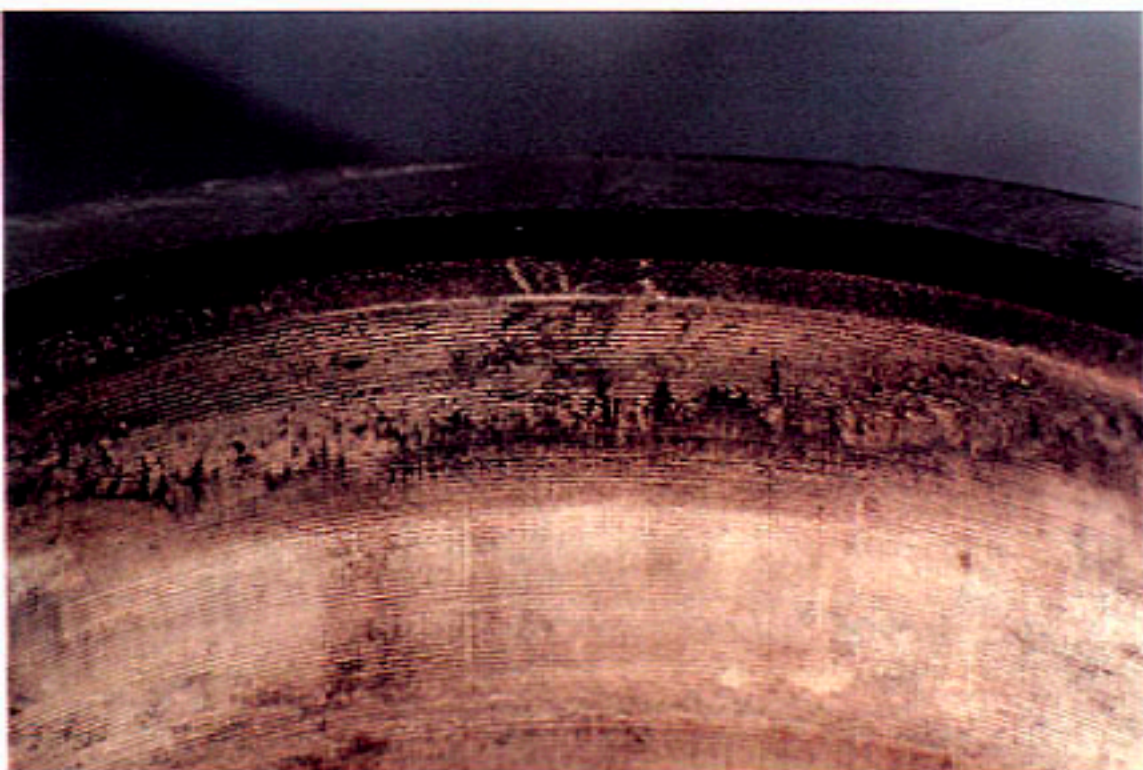

Plate 5

X3.5

The marking within the hole where arrowed on Plate 1 shown at two different magnifications. It can be seen that the original machining marks have not been removed even though the hole was 0.009 ins oval. The maximum diameter was at this position.

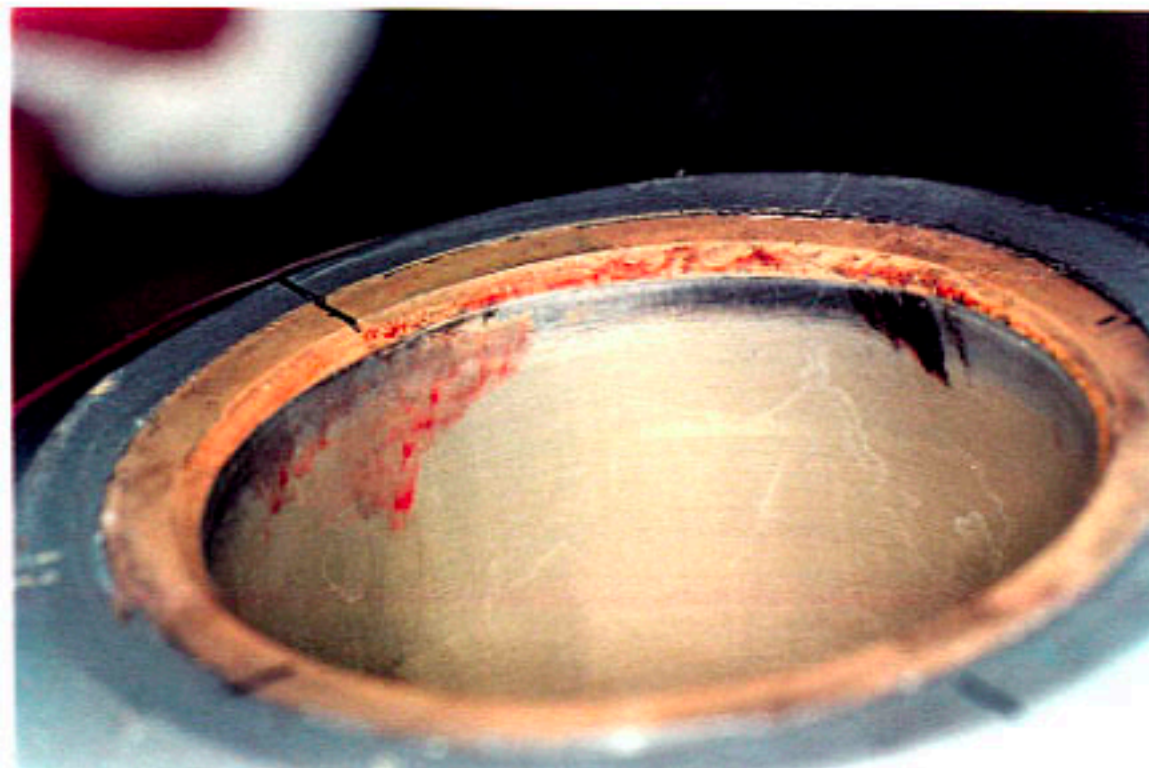

Plate 6

X2.21

Brake Plate Serial No. 0111 - April ,94 - Hong Kong incident - end of hole remote from brake pack - start of 'compression' mark around rim. Photograph taken at ABS, Slough immediately after removal of bush

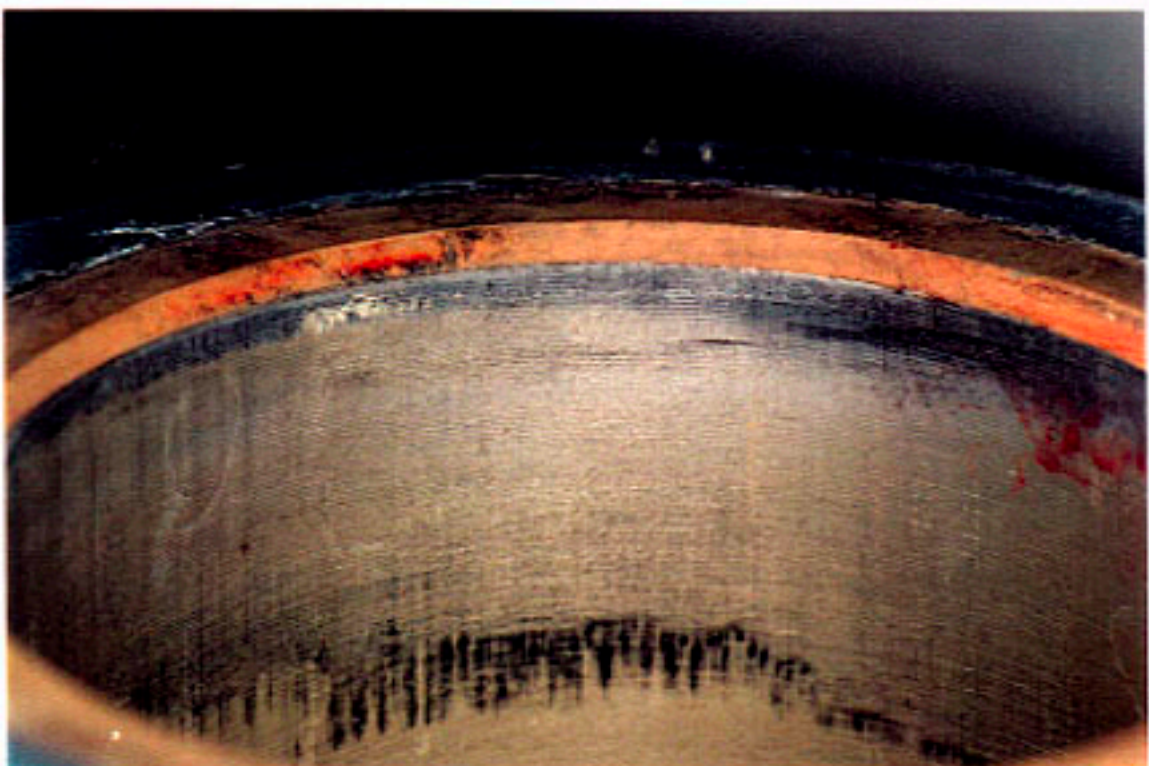
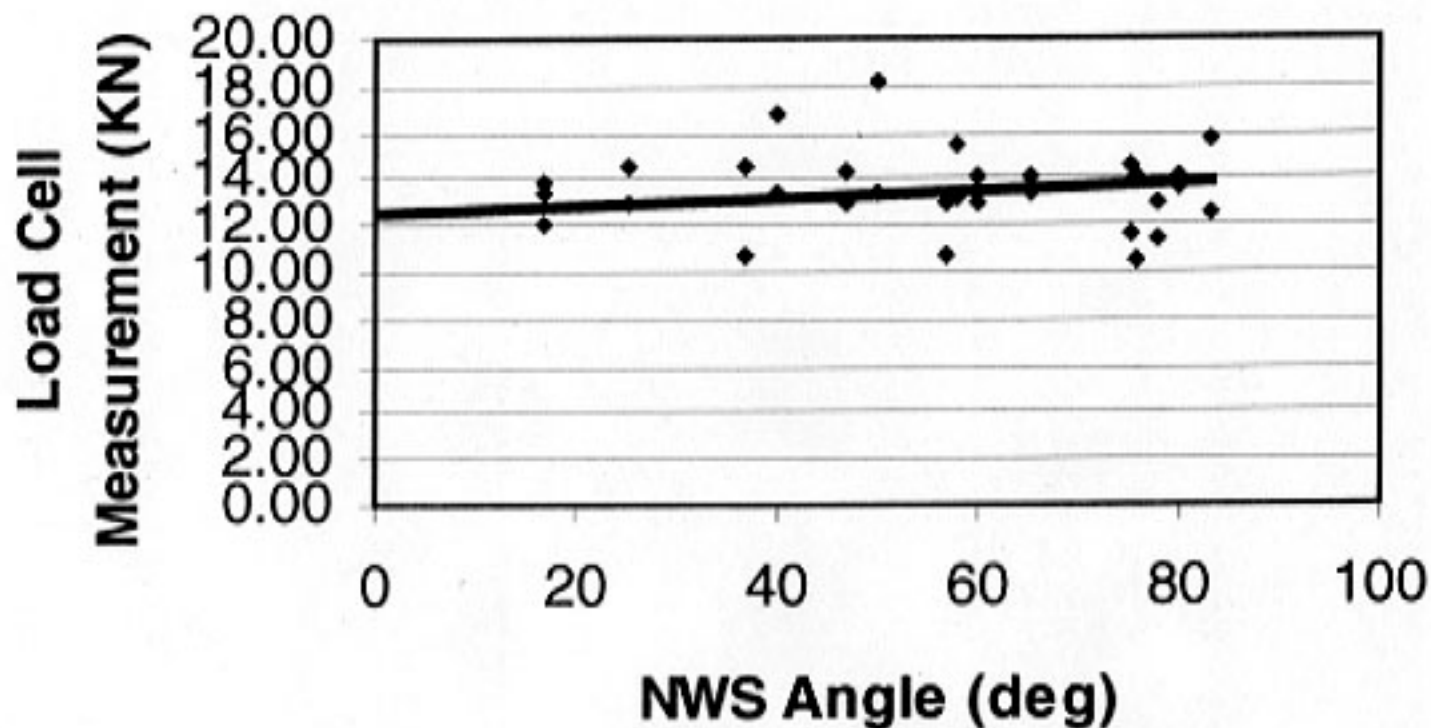

Plate 7

X2.82

As Plate 6 but further round hole.

# Load Cell Measurement Vs Steer Angle





### Estimate of Axial Component due to Brake Drag

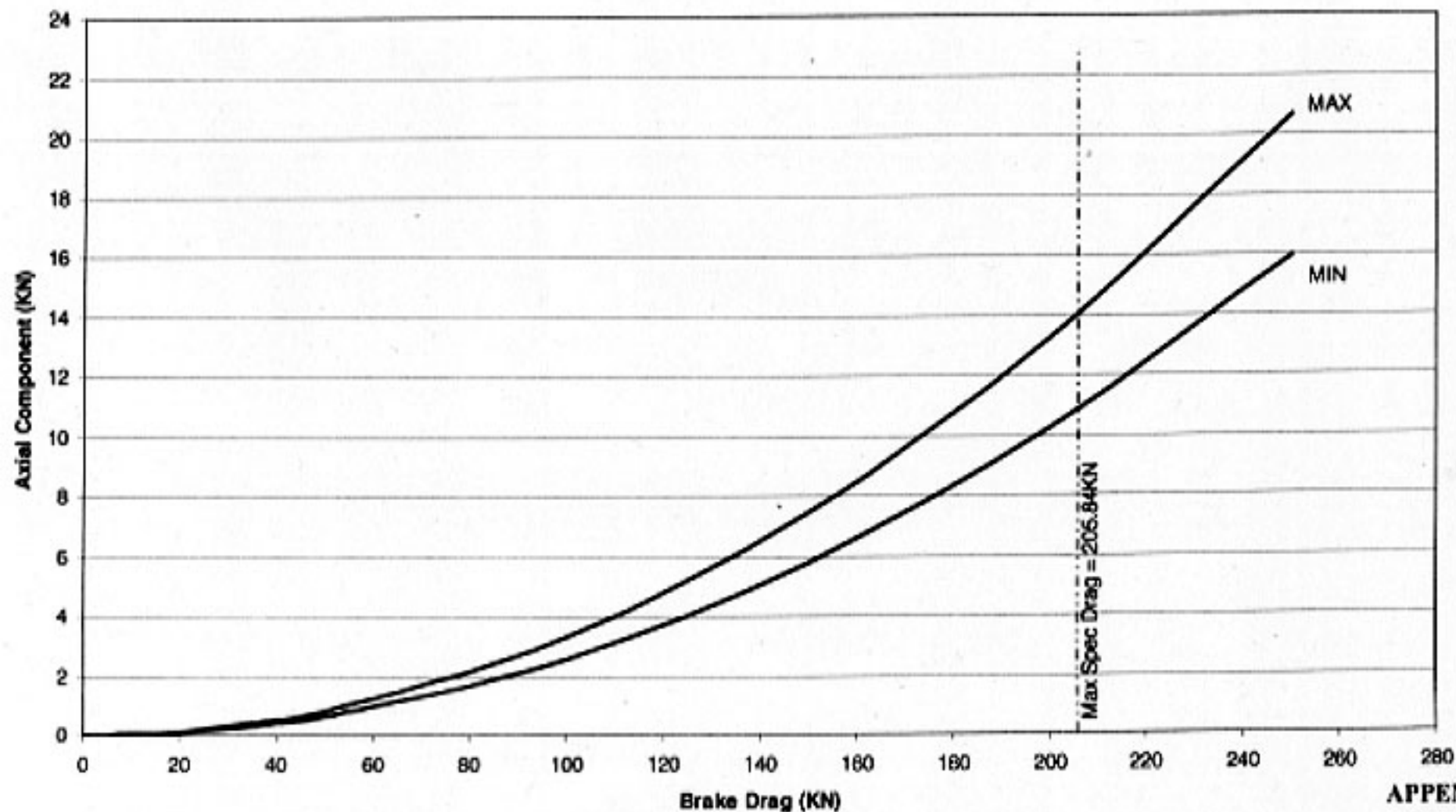

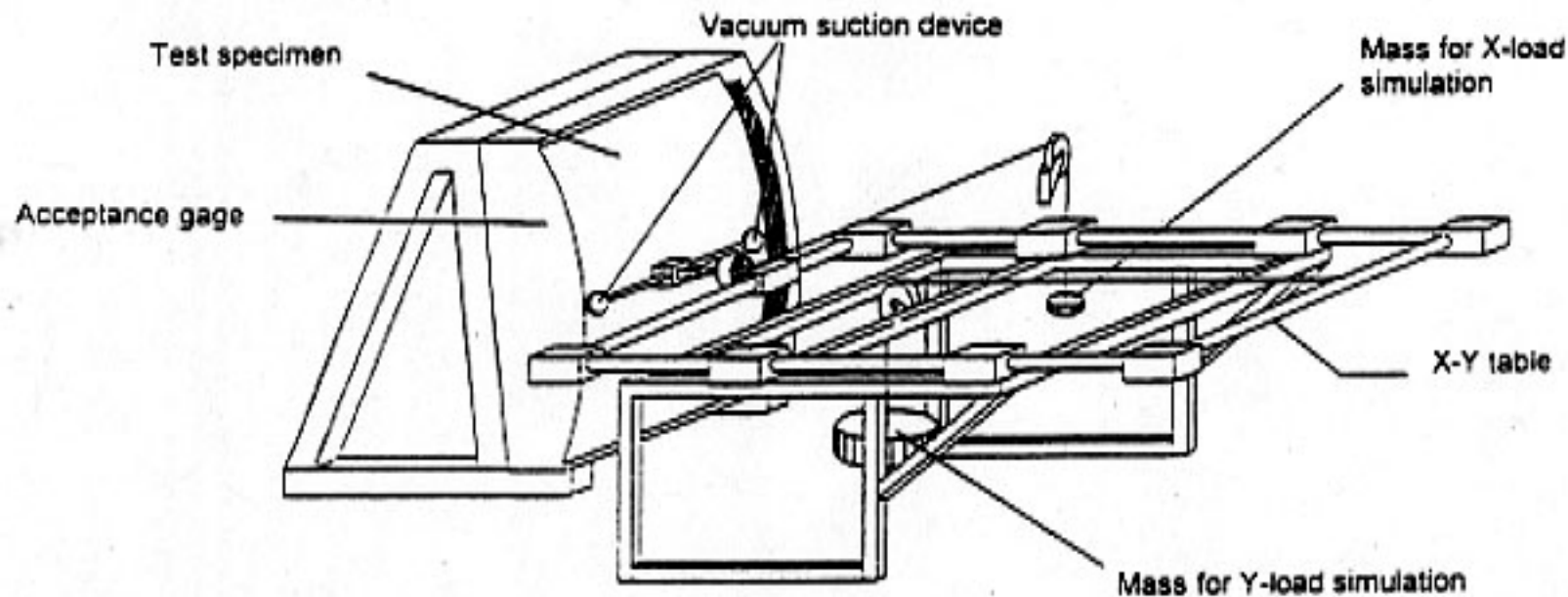

DOOR TEST RIG

Test No.	Y-Load [daN]	X-Load [daN]	Opening Time [s]	Load Case	Diagram No.	Door locked?	Remarks
02	0	0	2.4	Zero Load	1	Yes	„Virgin-Atlantic“ Cylinder SN 181
05	60.5	24.2	7.8		2	Yes	„Virgin-Atlantic“ Cylinder SN 181
07	60.5	27.2	8.2	Ultimate Load	3	Yes	„Virgin-Atlantic“ Cylinder SN 181
08	60.5	27.2	8.2	Ultimate Load	4	Yes	„Virgin-Atlantic“ Cylinder SN 181
09	60.5	27.2	8.1	Ultimate Load	5	Yes	„Virgin-Atlantic“ Cylinder SN 181
10	60.5	27.2	8.6	Ultimate Load	6	Yes	„Virgin-Atlantic“ Cylinder SN 181
12	22.1	2.3	4.0	„Virgin Load“	7	Yes	„Virgin-Atlantic“ Cylinder SN 181
13	22.1	2.3	4.1	„Virgin Load“	8	Yes	„Virgin-Atlantic“ Cylinder SN 181
14	22.1	2.3	4.1	„Virgin Load“	9	Yes	„Virgin-Atlantic“ Cylinder SN 181
15	22.1	2.3	4.2	„Virgin Load“	10	Yes	„Virgin-Atlantic“ Cylinder SN 181
16	22.1	2.3	4.4	„Virgin Load“	11	Yes	„Virgin-Atlantic“ Cylinder SN 181
17	60.5	27.2	6.7	Ultimate Load	12	Yes	Raber Cylinder FE 256 S/N 589
18	60.5	27.2	6.3	Ultimate Load	13	Yes	Raber Cylinder FE 256 S/N 589
19	60.5	27.2	8.0	Ultimate Load	14	Yes	Raber Cylinder FE 127.900.N1 (A300)
20	60.5	27.2	7.9	Ultimate Load	15	Yes	Raber Cylinder FE 127.900.N1 (A300)
21	60.5	27.2	8.6	Ultimate Load	16	Yes	Raber Cylinder FE 256.000 Prototype1
22	60.5	27.2	8.3	Ultimate Load	17	Yes	Raber Cylinder FE 256.000 Prototype1

# Emergency Opening Functional Test AIRBUS A330/340 PAX Door IV AC258 Ultimate Load Case

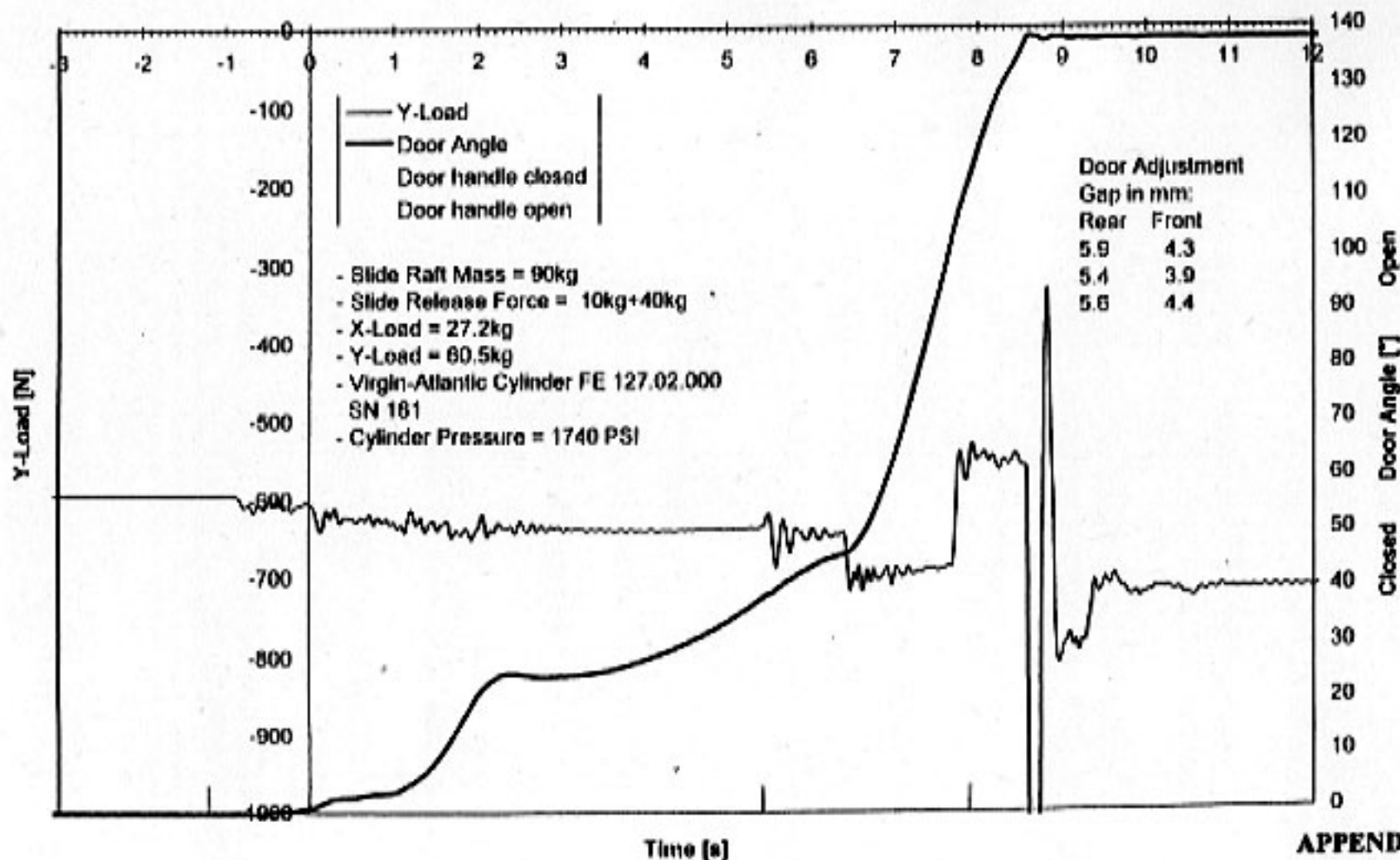

TEST No. 10 - Typical plot, worst case test conditions i.e. maximum adverse wind force and roll angle, using pneumatic cylinder taken from G-VSKY door 4R

**Emergency Opening Functional Test AIRBUS A330/340 PAX Door IV AC258  
"VIRGIN ATLANTIC A/C SN016" Load Case**

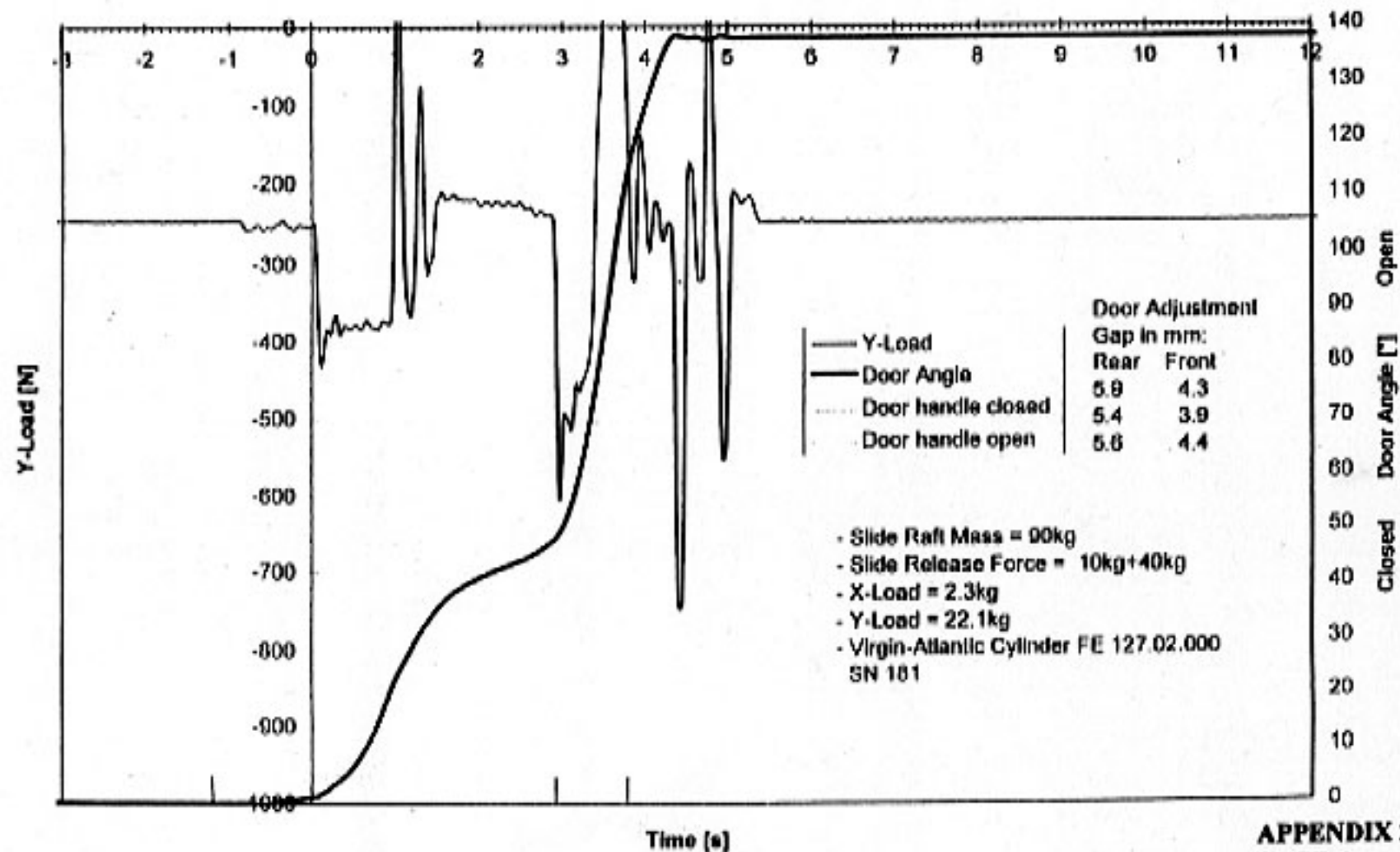

**APPENDIX 21  
PAGE 4**

TEST No. 16 - Typical plot, accident test conditions, using pneumatic cylinder taken from G-VSKY door 4R

## AD 1.2 - RESCUE AND FIRE FIGHTING SERVICES AND GROUND POWER

## AD 1.2.1 - RESCUE AND FIRE FIGHTING SERVICES

1 The categories of fire and rescue equipment given at AD 2.6, their relevance to individual aircraft, and the minimum scales of equipment required to meet the respective categories are contained in Civil Aviation Publication - 'Licensing of Aerodromes' - CAP 168. They approximate closely to those contained in the relevant ICAO publications.

2 For the convenience of aircraft operators the relationship of the fire and rescue equipment categories to individual aircraft is summarised as follows:

Aerodrome Fire and Rescue Category	Aircraft Overall Length (m)	Maximum Fuselage Width (m)
‡Special	0 up to but not including 9	2
1	0 up to but not including 9	2
2	9 up to but not including 12	2
3	12 up to but not including 18	3
4	18 up to but not including 24	4
5	24 up to but not including 28	4
6	28 up to but not including 39	5
7	39 up to but not including 49	5
8	49 up to but not including 61	7
9	61 up to but not including 76	7

‡Aerodromes which are generally licensed solely in order that flying instruction may take place.

3 Category of land based helicopter landing sites for Rescue and Fire Fighting purposes is as follows:

Site Category	†Aircraft Overall Length (m)
‡Special	0 up to but not including 15
H1	0 up to but not including 15
H2	15 up to but not including 24
H3	24 up to but not including 35

†Overall length includes rotors and tail boom

‡Aerodromes which are licensed solely in order that flying instruction may take place.

4 It should be noted that aircraft requiring ONE Category of fire and rescue equipment higher than that given at AD 2.6 are not automatically precluded from using the aerodrome. Operators of such aircraft should first consult with the aerodrome management.

5 Two tables have been produced to assist with determination of adequacy when comparing military and civil RFF categories. Each table uses different criteria in forming a comparison and commanders should only use the table appropriate to their flight details.

6 The following table compares ICAO minimum standards with those likely to be available at Government aerodromes. It is to be used by civil pilots wishing to use Government facilities

CAA Category	RAF Equivalent
1	2
2	4
3	4
4	4
5	6
6	7
7	No Equivalent
8	No Equivalent
9	No Equivalent

6.1 The above table compares minimum standards recommended by ICAO with those valid at Government aerodromes. Whilst compliance with these minimum standards is desirable, the Authority accepts that the slight shortfall in the facilities provided at RAF Category Two and Three aerodromes has been compensated for by significant over provision of facilities in some other areas. Therefore, operators may undertake, as a minimum, operation of Civil Category Two and Three aircraft from RAF Category Two and Three aerodromes respectively.

## AD 1-2-2 - CRASH/FIRE PROTECTION SERVICES

7 The following table compares crash/fire requirements for Government aircraft with those facilities likely to be available at Civil aerodromes. It is to be used by pilots of Government aircraft wishing to use civil facilities.

RAF Category	Civil/CAO Equivalent
Nil	1
1	2
2	3
3	5
4	5
5	6
6	7
7	8
-	8
-	9

7.1 Although no direct comparison can be made between RAF and the other fire categories, the above table is an approximation of the relationship between the categories.

AIP EXTRACT  
COMPARISON OF RFF CATEGORIES

MACELLES on GROUND CONTROL SPEED

No CrossWind

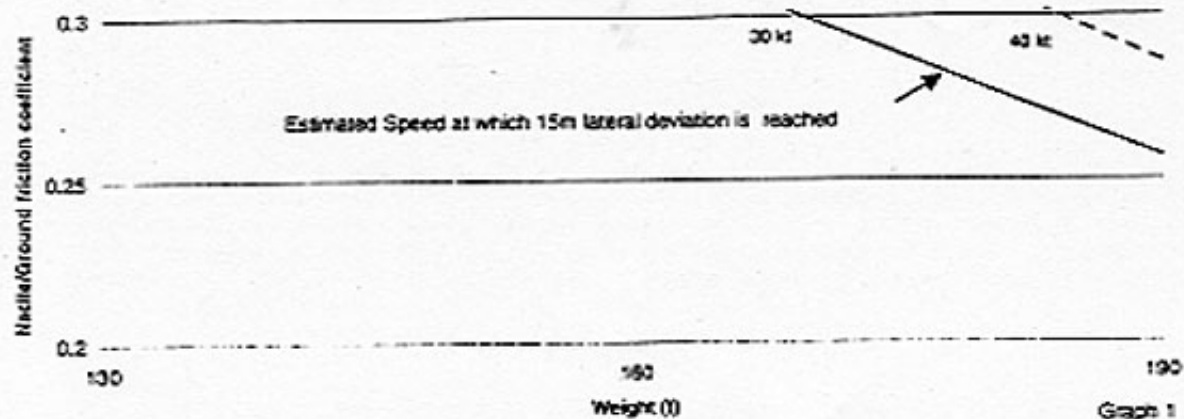

MACELLES on GROUND CONTROL SPEED

CrossWind -25 kt

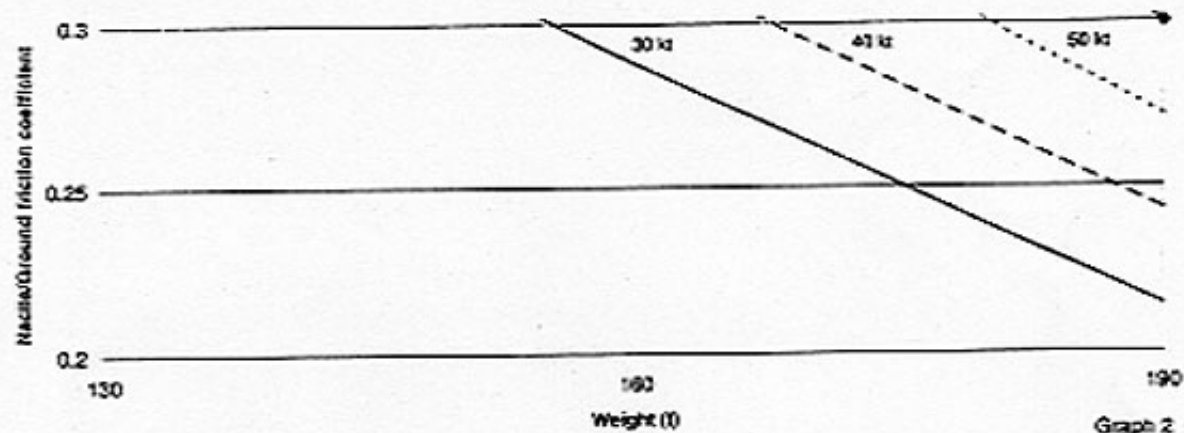

MACELLES on GROUND CONTROL SPEED

CrossWind + 25 kt

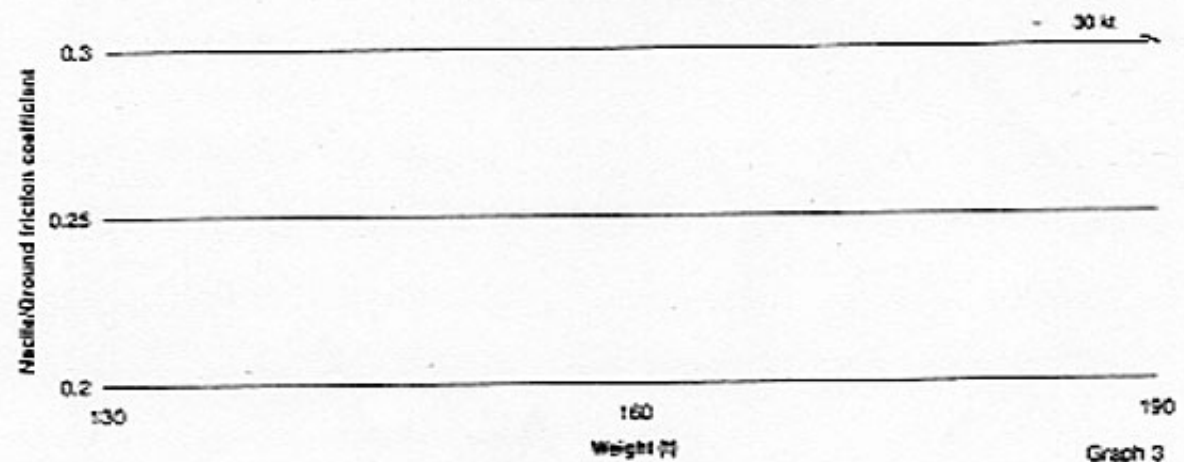



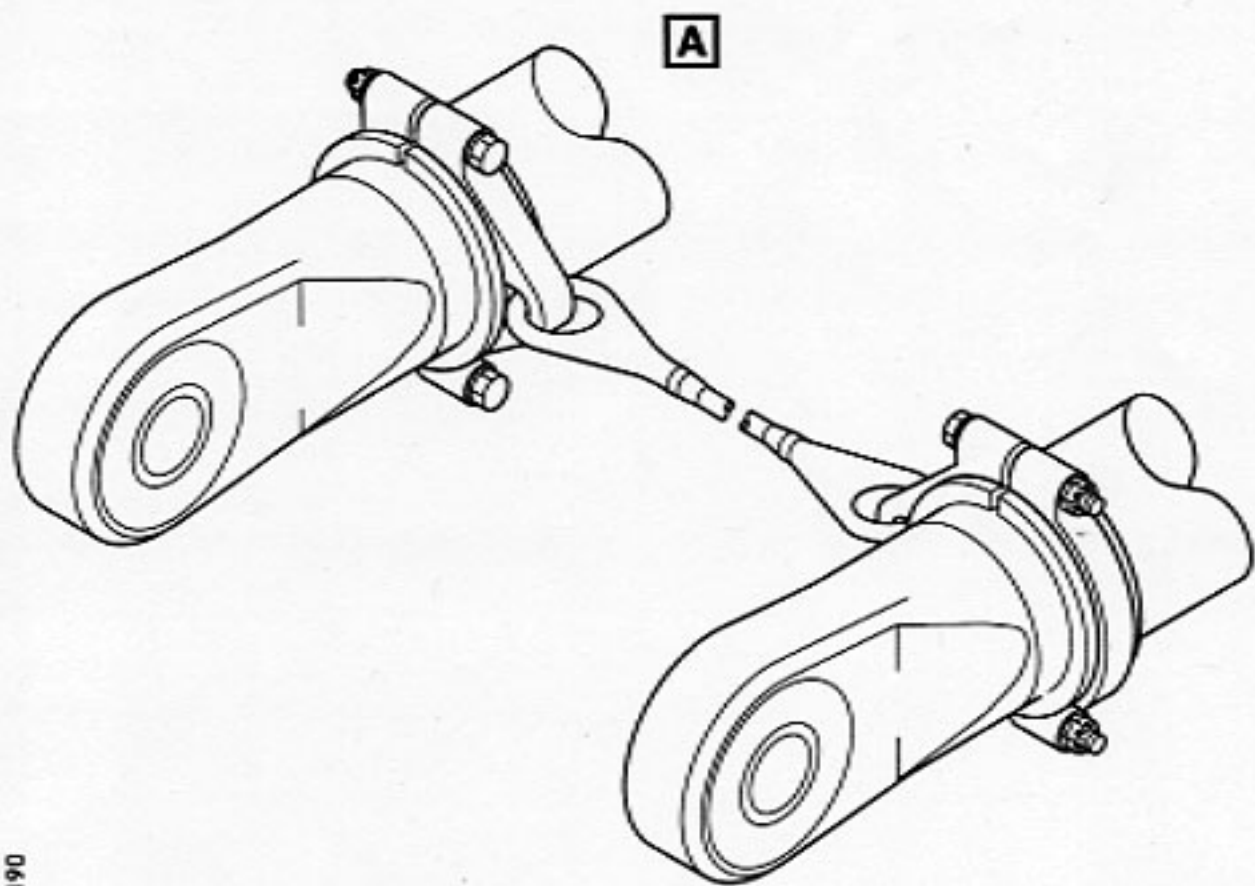
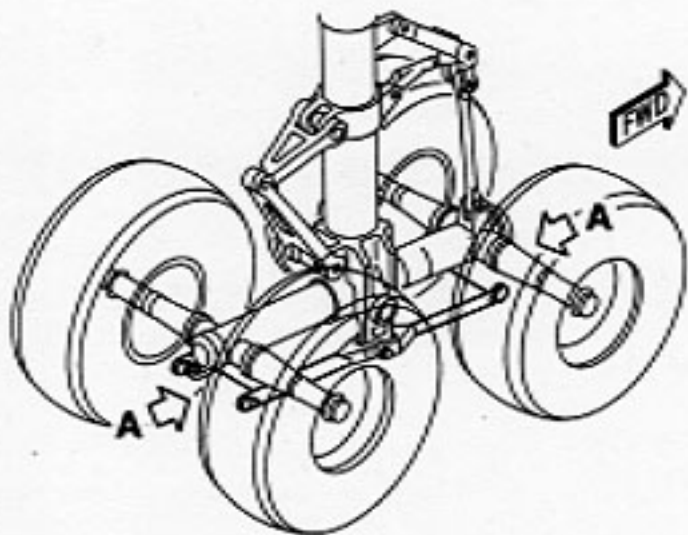

STUART 3190

**GROUND CLEARANCE DIAGRAM**

FFCS-03-0372-003-A900AA

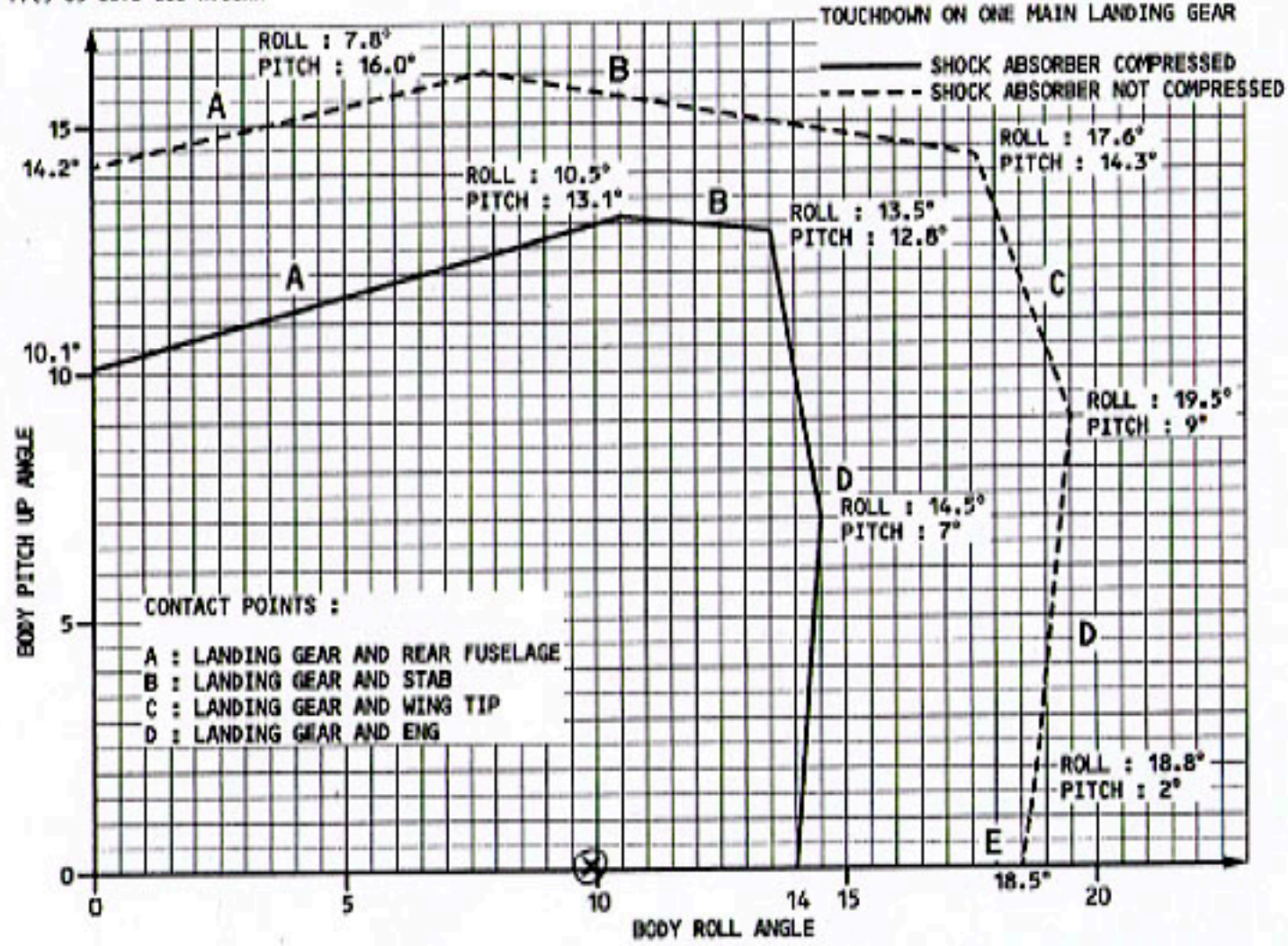

ALL

GROUND CLEARANCE DIAGRAM

APPENDIX 25

Aircraft Movements 1997	Total	Air Transport	Landing Dist Available (ft)	Runway Orientation	ILS 1/2	RFF
HEATHROW	440631	430708	11801	09/27	2	9
GATWICK	238836	229665	9075	08/26	2	9
MANCHESTER	168314	147404	8599	06/24	2	9
ABERDEEN	112540	86741	6001	16/34	2	7
STANSTED	104704	84333	10000	05/23	2	7
GLASGOW	98204	81609	7720	05/23	2	8
BIRMINGHAM	100721	79880	7477	15/33	2	8
EDINBURGH	99352	71884	7700	07/25	2	8
JERSEY	84975	49776	5098	09/27	2	6
NEWCASTLE	81279	42376	6972	07/25	2	8
EAST MIDLANDS	69958	40968	7480	09/27	2	7
LUTON	63686	40287	6808	08/26	2	7
BELFAST INTERNATIONAL	95009	35070	9111	07/25	1+1	8
BRISTOL	59547	31546	6155	09/27	2	6
LIVERPOOL	83354	28521	7300	09/27	2	6
LEEDS BRADFORD	57927	26123	5912	14/32	2	6
SOUTHAMPTON	55169	25703	5268	02/20	1	6
CARDIFF WALES	60724	18171	7001	12/30	2	7
TEESSIDE	66073	10970	7516	06/23	2	6
PRESTWICK	63166	10230	9800	13/31	2	6

UK AIRPORT MOVEMENT STATISTICS 1997 WITH DETAILS OF RUNWAY, PRECISION APPROACH AID AND NORMAL RFF CATEGORY