Uncontained engine failure, Air France, Boeing 747-128, F-BPVD, St. Jean, P.Q., Canada, August 17, 1970

Micro-summary: This Boeing 747-128 experienced an uncontained engine failure during climb, resulting in a diversion.

Event Date: 1970-08-17 at 2235 EDT

Investigative Body: National Transportation Safety Board (NTSB), USA

Investigative Body's Web Site: <http://www.nts.gov/>

Cautions:

1. Accident reports can be and sometimes are revised. Be sure to consult the investigative agency for the latest version before basing anything significant on content (e.g., thesis, research, etc).
 2. Readers are advised that each report is a glimpse of events at specific points in time. While broad themes permeate the causal events leading up to crashes, and we can learn from those, the specific regulatory and technological environments can and do change. ***Your company's flight operations manual is the final authority as to the safe operation of your aircraft!***
 3. Reports may or may not represent reality. Many many non-scientific factors go into an investigation, including the magnitude of the event, the experience of the investigator, the political climate, relationship with the regulatory authority, technological and recovery capabilities, etc. It is recommended that the reader review all reports analytically. Even a "bad" report can be a very useful launching point for learning.
 4. Contact us before reproducing or redistributing a report from this anthology. Individual countries have very differing views on copyright! We can advise you on the steps to follow.
-

SA-None

File No. C-0001

AIRCRAFT INCIDENT REPORT

**AIR FRANCE
BOEING 747-128, F-BPVD
ST. JEAN, P.Q., CANADA
AUGUST 17, 1970**

Adopted: October 7, 1970

**NATIONAL TRANSPORTATION SAFETY BOARD
Bureau of Aviation Safety
Washington, D. C. 20591**

In the interest of releasing reports at the earliest possible date, the National Transportation Safety Board has adopted this abbreviated accident/incident report format for cases where the issues and circumstances permit.

Air France
Boeing 747-128, F-BPVD
St. Jean, P.Q., Canada
August 17, 1970

<u>TABLE OF CONTENTS</u>	<u>PAGE</u>
Synopsis	1
Probable Cause	1
Investigation.	3
Analysis and Conclusions	5
Probable Cause	6
Recommendations	6
Supplemental Data	
Attachment 1	

NATIONAL TRANSPORTATION SAFETY BOARD
DEPARTMENT OF TRANSPORTATION
AIRCRAFT INCIDENT REPORT

Adopted: October 7, 1970

Air France
Boeing 747-128, F-BPVD
St. Jean, P.Q., Canada
August 17, 1970

SYNOPSIS

Air France Flight 030, a Boeing 747-128, F-BPVD, was a scheduled passenger flight which originated at Chicago's O'Hare International Airport at 1820 1/ e.d.t., on August 17, 1970. Its destination was Orly Airport, Paris, France, with an intermediate scheduled stop at Montreal, P.Q., Canada. At departure from Montreal, 174 revenue passengers, two infants, and a crew of 17 were aboard the flight.

The flight from Chicago to Montreal was normal in every respect. The takeoff from Montreal at 2226 was routine; however, approximately 9 minutes after takeoff, at 2235 at an altitude of 5,600 feet m.s.l., a separation of the second-stage turbine disk rim of the No. 3 engine occurred, and pieces penetrated and ruptured the high-pressure turbine case and associated engine cowling. The separation of the turbine disk rim resulted in a localized fire in the upper forward portions of No. 3 engine.

A fire warning, which came on simultaneously with the turbine failure, terminated after both containers of fire extinguishing agent were discharged. The No. 3 engine was shut down and the flight diverted to John F. Kennedy International Airport, New York, where it landed safely at 0004 (August 18). There were no injuries to passengers, crew, or persons on the ground.

The Board determines that the probable cause of this incident was the in-flight separation of the second-stage turbine disk rim of the

1/ All times used herein are eastern daylight based on the 24-hour clock.

No. 3 engine. The separation of the disk rim was the result of incorrect assembly of the high-pressure turbine module.

The Safety Board sent a letter to the Administrator of the Federal Aviation Administration (FAA) on August 21, 1970. This letter made recommendations relating to detection of dimensional discrepancies in the turbine module of the JT9D engine and immediate removal from service of any JT9D engines disclosing any dimensional discrepancies. The FAA took corrective actions essentially as recommended by the Board.

INVESTIGATION

Air France Flight 030 of August 17, 1970, was a regularly scheduled passenger flight between Chicago, Illinois, and Paris, France, with an intermediate stop at Montreal, P.Q., Canada. Flight 030 progressed normally until 2235, which was 9 minutes after takeoff from Montreal's Dorval Airport, while it was climbing through 5,600 feet m.s.l. over the St. Jean, Quebec VOR. 2/ At this time, an explosive sound was heard by the flightcrew, which was followed by the activation of the fire warning system of No. 3 engine. A cabin attendant reported seeing fire in the area of No. 3 pylon. Engine emergency fire procedures were initiated and No. 3 engine was shut down. Both of the available fire extinguishing agent bottles were discharged, and no further fire warning indication was noted on the engine fire control panel.

In an effort to identify the cause of the explosion and fire, the flight engineer went to the passenger cabin to view and assess damage to No. 3 engine through adjacent cabin windows. Because of darkness and insufficient illumination of the engine nacelle area, combined with the fact that the major damage was on the outboard side of the engine, a valid in-flight assessment of the damage was precluded.

Although there was no perceptible physical evidence of further fire on the inboard side of the engine, there was some apprehension about jettisoning fuel to attain the specified landing weight. Because of this, as an alternate means for reducing the airplane's weight to the maximum allowable for landing, the flight was diverted to John F. Kennedy International Airport at New York. Flight 030 proceeded to John F. Kennedy International Airport at an assigned cruising altitude of 18,000 feet m.s.l., at 280 knots indicated airspeed. At 0004, the aircraft was landed safely and the passengers were deplaned at the terminal.

Port of New York Authority initiated a 3-3 3/ alert indicating a potential hazard, and emergency equipment was on a standby basis during the approach and landing of Flight 030; however, it was not needed.

2/ VOR - Very High Frequency Omnidirectional Range

3/ The Port of New York Authority lists this alarm classification of an aircraft emergency to incorporate a potential additional hazard, with the equipment requested at standby position.

The No. 3 engine, serial No. P662498, had accumulated a total computed operating time of 267 hours and 58 operating cycles. ^{4/} Examination of it revealed a total separation of the second-stage turbine disk outer rim, which ruptured the engine high-pressure turbine case, and caused massive deformation of the adjacent engine structure.

The outer 2 inches (measured radially) of the rim, and the turbine blades, separated around the full circumference of the second-stage high-pressure turbine disk assembly. The separated fragments penetrated areas of the high-pressure turbine case. Examination of the No. 3 engine high-pressure turbine module disclosed that the second-stage turbine outer shroud assembly, part No. 661572, in the upper outboard quadrant was not engaged properly over the lip in the high-pressure turbine outer case inside diameter. ^{5/} It was found that the improper engagement of these two units caused the second-stage stator inner shroud to move rearward in this quadrant and contact the second-stage turbine disk web. Inspection of the quadrant where the inner shroud had moved rearward to contact the disk, disclosed protrusion of only one thread or less of the vane retaining bolts. Three threads of these bolts were observed in the other quadrants where there was proper engagement of the outer shroud to the case. Protrusion of three threads is considered normal by the Pratt & Whitney Division of United Aircraft, the manufacturer of the engine.

Examination of the manufacturer's records disclosed that the high-pressure turbine (HPT) module had been reworked at Pratt & Whitney to incorporate flared rivets in the first-stage turbine disk, and to modify the second-stage turbine disk.

Review of assembly and inspection procedures disclosed that there were written and pictorial instructions for torquing the 90 bolts securing the 30 vane segments. These instructions, however, did not provide for any specific sequence for accomplishing this operation. Also at the time the HPT module underwent final assembly, there were no provisions for making dimensional checks which could have detected improper positioning of mating parts.

^{4/} A cycle is defined as any flight consisting of one takeoff and one landing, regardless of the length of the flight or whether or not thrust reverser was used during landing.

^{5/} See Attachment 1 for illustration of proper and improper engagement.

Significant other aircraft structural damage resulting from the No. 3 engine failure was confined to the areas adjacent to and outboard of the engine. Structural damage to the No. 3 strut assembly was localized between nacelle stations 180 and 222. The exterior skin had several large tears, holes, and numerous punctures and dents. Most of this damage was on the outboard side of the strut. The inboard chord of the strut lower spar and the spar web were fractured, and the center spar web was fractured near nacelle station 200. The main generator cables (No. 3) routed above the center spar web were severed 8 inches aft of the splice area at nacelle station 193; however, the hydraulic, fuel, and pneumatic tubing routed through this same area was not punctured.

Fragments of the separated turbine disk rim caused minor damage to the wing leading edge high-lift devices and flap track fairings adjacent to the No. 3 strut assembly, and to the No. 4 engine nose cowl, and nose cowl inner inlet doors.

Other areas adjacent to No. 3 engine which received damage were the right-hand No. 1 leading edge flap and a pneumatic duct located above this flap. The damage consisted of small punctures and abrasions. The flap track fairings at wing buttock line (WBL) 353 and WBL 743 received minor abrasions and scratches. The inboard side of the WBL 743 fairing exhibited a 2-inch cut located 30 inches aft of the leading edge at its vertical centerline.

The No. 4 engine strut and cowling received minor damage and the No. 4 engine ingested fragments from No. 3 engine HP turbine. Varying degrees of foreign object damage were sustained by 23 of the 46 fan blades. The low-pressure compressor was also damaged. The overall damage necessitated replacement of this engine.

The fire warning system for the No. 3 engine was activated by fire in the upper portion of the engine. Also, the outboard side of the engine adjacent to the rear of the HPT case exhibited molten aluminum spray. Sooting and metal spray was also found on the remaining section of the right-hand side cowl panel and on the area surrounding nacelle station 196.

ANALYSIS AND CONCLUSIONS

The circumstances of this incident were such that the analysis can be devoted entirely to the condition leading up to the separation of the second-stage turbine disk rim of the No. 3 engine.

The engine was assembled and tested at the facilities of Pratt & Whitney, Division of United Aircraft, at Hartford and Middletown, Connecticut. The high-pressure turbine module, which was subsequently

installed in this engine, was not correctly assembled. The result was a transient condition of second-stage turbine disk rub against the second-stage turbine vanes, causing grooving of the disk in the rim area. This occurred during application of takeoff thrust when maximum gas velocities in a rearward direction existed. Progressive weakening of the disk around its periphery resulted in separation of the disk rim, and fragments of the rim penetrated the high-pressure turbine case and caused varied degrees of secondary damage and localized fire.

From the investigation of this incident, the Safety Board concludes the following:

1. The written and pictorial assembly procedures, which were available to production personnel involved in the assembly of the high-pressure turbine module, were not depicted in sufficient detail to preclude the type of assembly error which occurred.
2. Procedures related to the final inspection of the high-pressure turbine module were not effective in detecting the assembly error.
3. Existing inspection procedures required no final check of axial dimensions in the affected area.

Probable Cause

The Board determines that the probable cause of this incident was the in-flight separation of the second-stage turbine disk rim of the No. 3 engine. The separation of the disk rim was the result of incorrect assembly of the high-pressure turbine module.

Recommendations

On August 21, 1970, the National Transportation Safety Board forwarded the following letter to the Administrator, Federal Aviation Administration:

"The Board's preliminary investigation of the August 17th failure of the Air France Boeing 747, F-BPVD, No. 3 position JT9D-3A engine, 2nd-stage turbine assembly and associated fire disclosed a turbine rim separation.

"While the investigation is presently still in progress, no conclusive findings have at this time been made to pinpoint the exact source of the problem. We are aware and are appreciative of the deep involvement of your Flight Standards Propulsion Systems Staff in efforts to resolve this most serious matter.

"It is, however, known that the engine had been retrofitted with a late configuration turbine module approximately 250 flight hours prior to the incident.

"In view of the known potential results of a turbine failure, such as was experienced in this case, and the incomplete findings of the investigation, the Board feels the need for immediate steps toward eliminating some of the possible factors that may have been instrumental in precipitating the subject failure.

"Since rebuilding and reinstallation of the turbine module was involved in the subject engine, as well as approximately 250 other JT9D engines, the Board recommends that the Administrator initiate the following immediate action:

1. Review all assembly records and written procedures as they relate to critical fits, clearances, and dimensional checks covering the assembly of affected turbine module assemblies reworked to the latest configuration.
2. Review all installation records covering installation of reworked turbine module assemblies relative to fits, clearances, dimensional checks, and written installation procedures.
3. Effect immediate inspection of all JT9D engines whose records indicate questionable fits, clearances, installation procedures or material specifications, and effect immediate removal from service of any engine which discloses such discrepancies."

The Administrator's reply of September 4, 1970, outlining actions taken, is quoted, in part, below:

"1. A meeting was held in New York on 19 August 1970 between FAA, Pratt & Whitney Aircraft, and U.S. operators of B-747 aircraft to initiate prompt corrective action. It was established that this occurrence was not associated with any earlier known difficulties and had not occurred previously. As the result of this meeting, round-the-clock effort was established to uncover the problem area.

"2. A meeting was held at FAA Washington Headquarters on 24 August 1970 with Pratt & Whitney Aircraft and the Air Transport Association of America. At this meeting the National Transportation Safety Board was represented by your

Mr. Frank Taylor. The cause of the disc failure was reported by P&WA at this meeting. It was established that incorrect installation of the second-stage turbine stator vane outer support permitted the stator ring and seal to deflect and contact the second-stage turbine disc at takeoff power output, causing eventual failure of the disc. This engine had been operated 267 hours and had 58 operating cycles. P&WA was directed to review assembly tolerances, fits, and procedures with the FAA for adequacy for both production and field use. P&WA will revise assembly procedures and instructions as found necessary by this review.

"3. At the 24 August 1970 meeting, another meeting was scheduled for 26 August 1970, between P&WA, the airlines, Boeing, NTSB, and FAA for the purpose of developing inspection techniques and to establish the inspection program."

Following the last of these meetings, the FAA directed that a special inspection using a new X-ray technique be conducted to determine that the turbine stator is installed correctly. The FAA directed the inspection be conducted with the assistance of X-ray in accordance with instructions issued by Pratt & Whitney Aircraft. Engines were to be inspected under the following conditions, effective midnight, G.m.t., 26 August 1970:

"All engines now at Pratt & Whitney prior to shipment and all engines at Boeing prior to use in revenue service. A 10-percent sampling of the remaining engines which have 100 or less operating cycles will be made within the next 100 hours' time in service and will include engines which have had high-turbine module disassembly within the last 100 cycles. A copy of our alert wire of 27 August 1970 covering these inspections is enclosed.

Although there are good reasons to believe this is an isolated instance, the inspection program was undertaken to provide further reassurance. Should other instances of stator misalignment be found, additional steps will be taken immediately.

We believe the foregoing precautionary action is adequate and consistent with the intent of your recommendations."

In addition to the foregoing, the Administrator has initiated an inspection program to assure that adequate engine build-up procedures are established and followed. Also, an engineering design review of the engine is being made.

As a result of this incident and identification of the failure mechanism, the manufacturer's assembly and inspection procedures were revised to provide for sequence torquing of the 90 bolts securing the second-stage nozzle guide vanes and a measurement of critical axial dimension to ascertain correct assembly and fits.

On September 2, all inspections called for in the FAA engineering alert were completed, and the Safety Board was advised by the FAA that no assembly defects were found in the mating of the second-stage turbine outer shroud assembly of any other JT9D engine.

BY THE NATIONAL TRANSPORTATION SAFETY BOARD:

/s/ JOHN H. REED
Chairman

/s/ OSCAR M. LAUREL
Member

/s/ FRANCIS H. McADAMS
Member

/s/ LOUIS M. THAYER
Member

/s/ ISABEL A. BURGESS
Member

October 7, 1970

SUPPLEMENTAL DATA

Crew Information

Captain Jacques Mims was in command of Flight 030, with Louis Chauveau, the first officer, and Rene Cobut, flight engineer.

The crew held appropriate aeronautical certificates for the equipment operated and routes flown.

Aircraft Information

The aircraft, French Registry F-BPVD, a Boeing 747-128, had undergone final manufacturing processes and was certificated on July 14, 1970. The aircraft was delivered to and accepted by Air France on July 15, 1970.

The Boeing 747-128 was equipped with four Pratt & Whitney JT9D-3A turbofan engines, rated at 45,000 pounds of thrust at takeoff with water injection.

The No. 3 engine, serial No. P662498, had been installed on F-BPVD during the final production phases and had accumulated 267 operating hours.

NORMAL POSITION
OF INNER SUPPORT

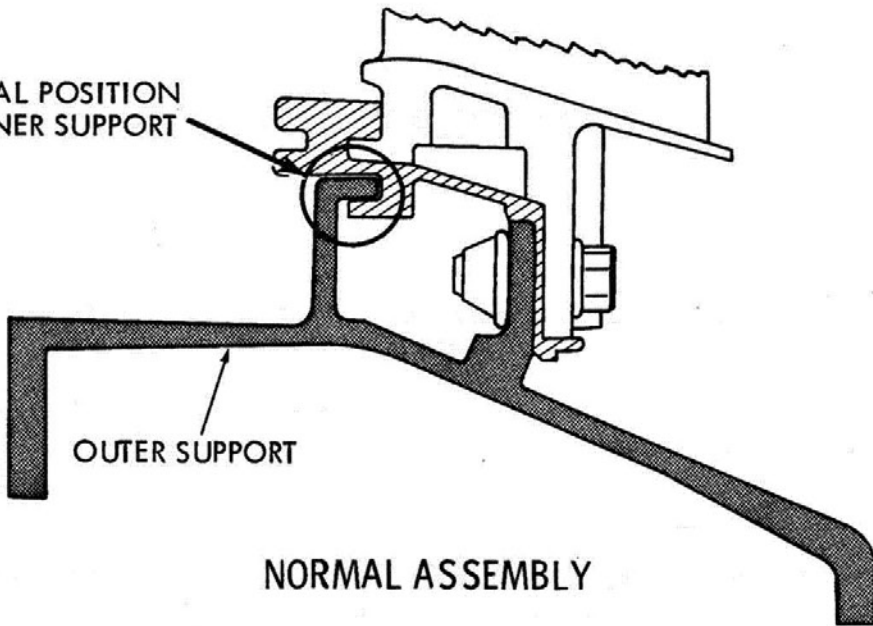

NORMAL ASSEMBLY

POSITION OF INNER
SUPPORT DUE TO
IMPROPER ASSEMBLY

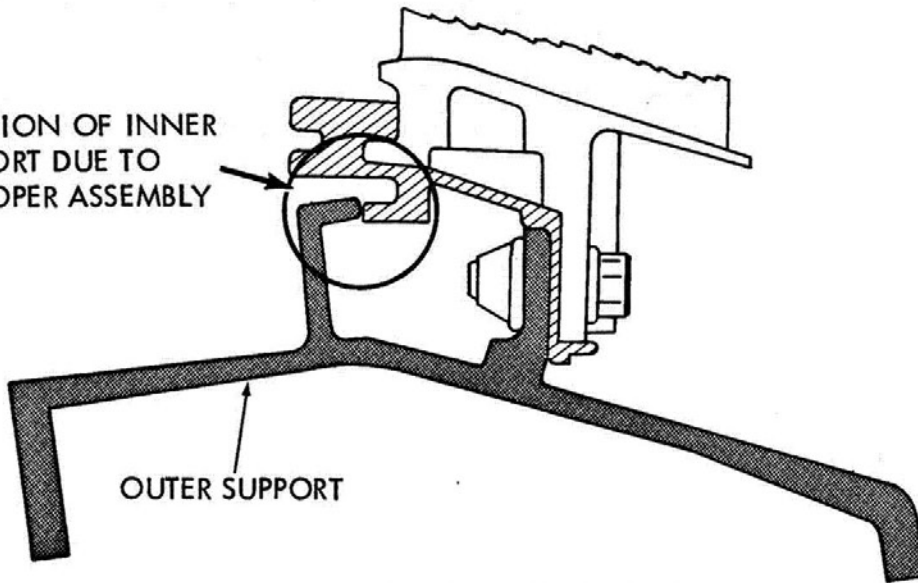

INCORRECT ASSEMBLY

NATIONAL TRANSPORTATION SAFETY BOARD
DEPARTMENT OF TRANSPORTATION
WASHINGTON, D.C.
JT9D-3A, S/N P662498
AIR FRANCE - BOEING 747-128 F-BPVD

**Intentionally Left Blank
in Original Document**