Incorrect airspeed indications, UPS 747-200 at Dublin Airport, May 12, 2000

Micro-summary: Static drain ports yielded very low airspeed readings in an engineering test flight of this 747-200.

Event Date: 2000-05-12 at 1325 UTC

Investigative Body: Air Accident Investigation Unit (AAIU), Ireland

Investigative Body's Web Site: <http://www.aaiu.ie/>

Cautions:

1. Accident reports can be and sometimes are revised. Be sure to consult the investigative agency for the latest version before basing anything significant on content (e.g., thesis, research, etc).
 2. Readers are advised that each report is a glimpse of events at specific points in time. While broad themes permeate the causal events leading up to crashes, and we can learn from those, the specific regulatory and technological environments can and do change. ***Your company's flight operations manual is the final authority as to the safe operation of your aircraft!***
 3. Reports may or may not represent reality. Many many non-scientific factors go into an investigation, including the magnitude of the event, the experience of the investigator, the political climate, relationship with the regulatory authority, technological and recovery capabilities, etc. It is recommended that the reader review all reports analytically. Even a "bad" report can be a very useful launching point for learning.
 4. Contact us before reproducing or redistributing a report from this anthology. Individual countries have very differing views on copyright! We can advise you on the steps to follow.
-

FINAL REPORT

AAIU Report No: 2004-004

AAIU File No: 2000/0032

Published: 6/2/2004

Operator:	UPS
Manufacturer:	Boeing
Model:	B747-200
Nationality:	U.S.A.
Registration:	N520UP
Location:	Dublin Airport
Date/Time (UTC):	12 May 2000 @ 13.25 hrs

SYNOPSIS

The aircraft took off from Dublin Airport for a check flight following the completion of "C" check maintenance at Team FLS. After take-off, significant airframe vibration was encountered. The crew then deduced that both airspeed indicators were under-reading significantly. Following declaration of an emergency, and trouble-shooting by the crew off the east coast of Ireland, the aircraft returned safely to Dublin. After landing it was discovered that the flap system had suffered damage. It was found that the static drain ports in the Avionics and Electrical (A&E) bay, connected to both the Captain's and the First Officer's instruments, were left open after maintenance. This resulted in both airspeed indicators under-reading by a significant amount.

NOTIFICATION

Dublin ATC notified this incident to the AAIU immediately after the occurrence, on Friday 12 May 2000. The initial report indicated vibrations in flight controls and problems with instruments. The full seriousness of the occurrence was not realised until Monday 15 May 2000. The Chief Inspector of Accidents, Mr. Kevin Humphreys, then directed that a full AAIU investigation be initiated. The Inspector-in-Charge was Mr. Graham Liddy, assisted by Mr. Frank Russell.

1. FACTUAL INFORMATION

1.1 History of the Flight

The crew arrived at the aircraft about two hours before take-off. The purpose of the flight was to perform a post "C" check test flight. In the terminology of the aircraft operator, this is known as a "Conditional Test Flight".

FINAL REPORT

During the pre-flight tests no problems were experienced until a point during the flight control checks, when the spoiler panels were deployed, while moving the control wheel fully left. As a control wheel passed through 1/3 to 2/3 of full roll travel, a noticeable airframe vibration was detected. At this point the control checks were suspended and trouble-shooting of the vibration problem commenced. The Second Officer observed flutter at the No. 8 spoiler panel, which is located on the right wing, as it was extended, following left roll control input. The operation of the B747 spoiler system is described in paragraph 1.6.5 below.

The Second Officer reported the vibration and spoiler flutter to the maintenance provider's Inspector who was on board the aircraft. The Inspector did a visual inspection of the spoiler during operation. He noted the vibration and spoiler flutter, but believed it was not a cause of concern. The Inspector, who was experienced on the B747 airframe systems, believed that the flutter was caused by a low flow rate, or air, in the hydraulic system and he informed the Commander that it should disappear following engine start. No further problems were encountered during the remainder of the pre-flight checks. The aircraft was then towed to Stand 7B.

On Stand 7B the following took place.

- All engines were started.
- The flight controls check was repeated.
- Flaps were extended.
- Spoilers were deployed.
- Personnel on the ground, who communicated with the flight crew by radio, verified correct operation of the flight controls.
- The left roll control input was repeated and the vibration was still noticeable.

Further discussion between the flight crew and the maintenance inspector on the matter of the vibration followed. The maintenance Inspector stated that it was not a significant problem. Furthermore, the flight crew were comforted by the fact that the spoilers would not normally be deployed in flight, in the speed brake mode, and that they would not be deployed in flight in the ground spoiler mode. It was therefore deduced that any minor defect in the spoiler system could not pose a danger to flight. Thus it was decided that the aircraft was safe for flight. There was a total of eight persons on board; the three-member flight crew and five technical personnel from the maintenance provider organisation.

The aircraft then prepared for the test flight. As a contingency, the Commander did brief the crew on the actions to be taken in the event of flight control problems. On the take-off roll, at 13.15 hrs on Runway (RWY) 10, the pilots compared airspeed indicators (ASI) at 80 kts, and found no disparity. Take-off appeared normal, but slightly longer than expected. At 131 kts, the Commander rotated the aircraft and put the aircraft into the normal pitch attitude for take-off. V_2 was 151 kts. The crew did verify that maximum rated thrust was achieved on take-off, and after take-off the engines thrust was reduced. When the gear was retracted, an abnormal airframe vibration was noted.

FINAL REPORT

The Commander suspected that it was a recurrence of the spoiler problem, while the First Officer believed that an undercarriage door might have remained open. The undercarriage lights indicated that the undercarriage was retracted and that all doors were closed. However the crew decided to leave the undercarriage lever in the “up” position, to ensure that the door retraction mechanism was pressurised.

At 800 feet, as per normal procedure, a pressurisation pack was brought on-line. Simultaneously the wind shear alarm activated. The Commander noted that there was a small weather cell south of the airfield and initially believed that this may have triggered the wind shear alarm. The Commander called for more thrust in response to this warning. At this point the speed was reducing towards V_2 , but aircraft climb rate was only an indicated 400 to 500 ft per minute. Approximately 10 seconds later the second pressurisation pack came on and another loss of airspeed was noted. Again the Commander called for more power. Shortly afterwards the aircraft broke out on top of the cloud layer, at about 1,500 ft. The Commander realised that the weather conditions were benign and could not be the cause of the wind-shear warning. It was also noted that the vibration level was increasing.

During the climb, with normal engine power settings and aircraft pitch attitude, the airspeed indication was significantly lower than expected. The Captain attempted to maintain 200 kts but determined that the airspeed and altitude indicators on both sides of the cockpit were under-reading by a significant amount. This was verified by comparing the ASI indications with the ground speed indicated by the aircraft navigation system. At about this point, at an indicated speed of 180 kts, the Commander initiated the standard turn to the right as required for the Standard Instrument Departure (SID) for RWY 10. During this turn the indicated airspeed reduced towards 160 kts and the aircraft started to descend at about 500 ft per minute. The Commander rolled the aircraft level, and then re-attempted the turn, but more gently, with similar results – reducing airspeed and reduced rate of climb, coupled with increased vibration.

At this point the Commander decided to abort the flight and to return to Dublin, and so instructed the crew. He initiated a left turn to commence the return to Dublin Airport, but was concerned as this resulted in a track towards poor weather and cloud. At the same time his altimeter was going from electric to barometric mode. He repeatedly tried to reset it into electric mode, but it kept reverting into barometric mode, as the aircraft was now above the maximum altitude that the radio altimeter can display (2,500 ft). He also observed that when it changed mode the needle did not move and neither did the Instantaneous Vertical Speed Indicator (IVSI). He noted that the pitch attitude indicator was pointing down. He crossed checked this with the stand-by pitch indicator and determined that his pitch information was good. At this point the speed indication had risen towards 225 kts. He brought the nose above the horizon and reduced power. He then turned the aircraft back to the right to avoid the weather, and to bring the aircraft into a clearer area, having briefed the crew that he was determined to stay clear of cloud, because of the problems with the aircraft. As they were no longer able to comply with the ATC clearances they declared an emergency to ATC, and headed towards clearer weather to the east of Dublin Airport.

FINAL REPORT

The Commander cycled the spoilers in the speed brake mode, expecting some change in vibration levels or in the flight controls if the problem was in the speed brake system. However there was no such change. The aircraft Inspector, located in the rear of the aircraft, observed slight float on some spoiler panels (partial opening) and heavy vibration in the flaps. At this point the Commander had no faith in his airspeed indications, which were reading 190 – 200 kts. He had no idea of his true altitude except that he was staying on top of the clouds. ATC passed the aircraft's altitude, as shown on their radar to the aircraft. However these corresponded to the altimeter readout, which the Commander believed to be unreliable.

ATC gave vectors to guide the aircraft into clearer airspace to the east, and the flight crew set about evaluating the situation for landing. At 190 – 200 kts, they selected Flaps 25, the normal approach configuration. This caused the flap overload light to illuminate, and the flaps failed to fully deploy, indicating that the true airspeed was too high for that flap setting, even though the indicated airspeed was within the permissible range. They then raised the flaps to Flap 10. The aircraft was more controllable at this setting. The Commander then gave control of the aircraft, for a brief period, to the First Officer, so as to obtain his evaluation of the situation. At this stage the Forward and Aft Cargo door warning lights came on for a brief period. The crew obtained a weather check for Dublin and for Shannon. Shannon was a considered option, due to its longer runway. However the weather there was significantly poorer than in Dublin. At this point the First Officer observed a break in the cloud cover, approx 25 miles east of Dublin. They decided to descend through this break, maintaining visual contact with the sea/ground and make an approach with Flap 10, while using radar vectors to get them back to Dublin. The descent was safely accomplished and the runway lights of Dublin were picked up (the Dublin ILS was inoperative at this time). When the visual glide path was intercepted, the speed was reduced from 190 kts towards 160 kts, which is the manoeuvring speed for Flaps 10 at the aircraft's landing weight. As the speed was reduced, the vibration level decreased.

On the approach, at about 170 kts indicated airspeed, the on-board Inertial Navigation System (INS) was indicating about 250 kts groundspeed, and ATC reported that their system showed that the groundspeed was about 300 kts. The Commander did not know which system, if any, was accurate, He was aware, as he approached the ground, that the speed was higher than normal. The technical personnel on board were briefed for a possible evacuation. The engine power setting was unusually low, due to the small amount of flap (Flap 10) used. The aircraft crossed the airport fence at 170 kts indicated and touched smoothly about 1,000 ft past the runway threshold. The landing was performed with automatic spoiler deployment disarmed (in case their deployment should cause control problems), and the auto-brake was set at medium.

After touchdown, the Commander used aerodynamic braking, manual deployment of the spoilers and engine thrust reversing to slow the aircraft. This was accomplished without any problem. During the landing the brake temperature indications did not exceed the amber range.

FINAL REPORT

However, being aware that he had landed faster than normal, the Commander advised ground personnel not to approach the main landing gear, for fear of an explosive deflation of hot tyres, and to chock only the nose wheel. The emergency services at Dublin Airport were in attendance throughout the landing, and subsequent taxiing and parking of the aircraft. The flight had lasted 39 minutes.

1.2 Injuries To Persons

There were a total of eight persons on the aircraft during the check flight. No injuries were reported to the investigation.

Injuries	Crew	Passengers	Others
Fatal	0	0	0
Serious	0	0	0
Minor	0	0	0
None	8	0	

1.3 Damage To Aircraft

The seals at the fixed trailing edge flap fairings at No.1 and No.8 position were blown out and the trailing edge boat fairings were also damaged. A crack was found in the left hand outboard leading edge flaps. A significant inspection was made of the aircraft, particularly relating to possible damage relating to an exceedance of maximum flap speed. No other damage was found. During the course of this inspection the No.8 spoiler actuator was changed.

1.4 Other Damage

There was no other damage

1.5 Personnel Information

The flight crew were all very experienced personnel. The Commander (aged 55) had 22,900 hours flight experience. The First Officer (also aged 55) had similar experience, and was also a fully rated Captain. Both the Commander and the First Officer were FAA-authorized Check Airmen. The Second Officer (aged 45) had 12,000 hours experience and was an FAA-authorized Check Airman (Flight Engineer). The main function of the members of the crew, in their company, was to perform pilot checks and to perform post-maintenance check flights. They had performed over 100 such post-maintenance check flights.

1.6 Aircraft Information

1.6.1 Leading Particulars

Aircraft type: B747-212B (Freighter)
Manufacturer: Boeing
Constructor's number: 21943

FINAL REPORT

Year of manufacture:	1980
Total airframe hours:	66,582
Engines:	P&W JT 9D-7Q (four)
Take-off weight:	490,000 lbs

1.6.2 Pitot-Static System

1.6.2.1 System Information

Aircraft are equipped with sensing ports that detect static and dynamic air pressure. The location of the static ports is designed to ensure that they accurately measure the ambient static air pressure. Static air pressure is affected by altitude and atmospheric pressure. The dynamic pressure is measured on a forward facing sensor, and is proportional to aircraft airspeed.

The static pressure is used to measure aircraft altitude. Comparison of the differential between dynamic and static pressure gives a measurement of indicated airspeed.

1.6.2.2 The B747-200 is equipped with 4 pitot-static probes. These are located in pairs, one pair on each side of the cockpit, located just below the cockpit side windows. Each pair of probes consists of an upper (main) and lower (auxiliary or aux) probe. **Appendix A** is a simplified schematic of the static system, showing only the static system that is connected to the flight instruments and the drains in the A&E Bay.

Each of these probes features a forward facing hole, which is the dynamic pressure indicator. Further back along the probe, on the side of the probe, are 2 sets of lateral holes. These are the points where static pressure is measured. It should be noted that each probe provides 2 separate static pressure inputs. It should be further noted that static ports on either side of the aircraft are interconnected to minimise any error due to sideslip.

The upper left (main) probe forward static port (S1) is connected to the lower right (aux) probe rear static port (S2) and this is the Captain's instrumentation main static source. This provides static pressure inputs to his ASI, altimeter and IVSI. The lines coming from the static probes are routed through a selector valve and then into a manifold that in turn distributes the static pressure to his instruments. The selector valve allows the Captain to select static pressure from the standard probes, as noted above (NORMAL position) or from the common alternative static source (see below). Between the selector valve and the manifold, a tee piece junction is located. From this junction the static line is connected to the No.1 Air Data Computer and the static line drain (Captain's side).

Similarly the upper right (main) probe forward static port (S1) is connected to the lower left (aux) probe rear static port (S2) and this is the First Officer's (F/O) instrumentation main static source.

FINAL REPORT

The rest of the layout is similar to the Captain's side, routing through the F/O's selector valve, which again allows the F/O to select the standard probes (NORMAL position) source, or common alternative (ALT) static source. In the case of the tee piece in the F/O's line, the connection is to the No.2 Air Data Computer and the static line drain (F/O's side).

Both Air Data Computers and their associated drains are located in the forward A&E Bay. The drains are to drain moisture from the system. Normally these drains are sealed by means of blanking caps. However, it is possible to connect instrumentation onto these drains for the purpose of performing leak checks on the static system. This requires removal of the blanking caps.

The other static ports on the main and aux probes are not connected to flight instruments (nor to the drains in the A&E bay that are connected to the flight instrument static system) but are used to supply static air pressure to a variety of other systems, including flight control modules. The connections of these other static ports are not shown in the diagram of **Appendix A**, for reasons of clarity.

There are two further ALT static ports, again one on each side of the fuselage, located near the forward cargo area. These two ports are interconnected and provide a common ALT static source to both the Captain's and F/O's instruments, via their respective selector valves.

The A&E Bay is located within the pressure hull of the aircraft. Therefore the ambient air pressure within the bay is that which is produced by the aircraft's pressurisation system. This pressure is higher than the outside ambient air pressure and the differential increases with altitude.

1.6.2.3 Checking the Static System

It is essential to ensure that there are no leaks in the pitot-static system. In particular, a leak in the static system, within the aircraft, will result in higher pressure air coming from the pressurised environment inside the aircraft, entering the static system, and causing a higher than normal pressure within the static system. This causes the airspeed indicator and the altimeter to under-read.

Therefore it is laid down in all major check procedures, such as a "C" check, that the pitot-static system will be checked for leaks. It is also normal to conduct leak checks following any maintenance on the static system, or when connected instruments are changed.

On the B747 there are two methods of checking the static system for leaks, as laid down in the Boeing Maintenance Manual:-

- The first method is to fit an adaptor (Part No. T856-660) onto the probe. The corresponding static port on the other side of the aircraft is blocked off, using tape. A vacuum is applied to the probe adaptor using a test rig, and the leakage rate is checked. There is a problem with this procedure, in that it can be difficult to get a good seal between the adaptor and the probe.

FINAL REPORT

This is particularly difficult where the surface of the probe has become pitted and corroded. The anti-icing heating element in the probe accelerates the onset of such corrosion and pitting, in normal use.

- The second method lays down that the static system can alternatively be tested for leaks by blocking the ports on both probes and by connecting the vacuum test rig to the static drain connection in the forward A&E Bays, which is located underneath the cockpit area. This involves the removal of the blanking caps that normally cover these drains, followed by the connection of the test rig to the open drains. As this procedure does not use the adaptor, the sealing problem on the probe does not arise.

1.6.3 Maintenance Manuals

The Boeing Company produced an Aircraft Maintenance Manual (AMM) for the B747 and provides a service for the updating of the AMM. Boeing also provides an AMM revision service that is customised to a given serial number aircraft. This aircraft was originally delivered to Singapore Airlines (SIA) in 1980 and was subsequently purchased by UPS in 1986. According to Boeing records, UPS does not have a Boeing provided AMM revision service for this particular aircraft serial number, and Boeing continues to provide AMM revisions to SIA.

UPS produces its own AMM and revisions for their B747 fleet.

1.6.4 Approved Procedures

The UPS-produced Boeing B747 Maintenance Manual Reference UPS 52081, Revision 79 issued 25 April 1991 lays down the methods for checking the static system, using either of the procedures noted above. However this version of the Manual was superseded by Consolidated Maintenance Manual, Reference UPS 52001, Revision 13, issued in May 1999. This revised AMM covers N520UP. The revised version makes no reference to using the drains in the A&E Bay for the purpose of performing leak tests in the static system. It does state that connection of the test rig to the pitot-static system is by means of an adaptor connected to the pitot-static probes (i.e. the first procedure given above in 1.6.2.3).

The Boeing Company has confirmed to the Investigation that their AMM for the B747 permits the two methods of checking the static system as per the Boeing-provided AMM D6-30033 Rev 87 dated 25 April 2000.

1.6.5 Spoiler System

The Boeing B747 –200 is equipped with 12 spoiler panels, 6 on each wing. They are numbered 1 to 12, starting on the left outer panel. The spoiler panels are located in 2 groups on each wing. On the right wing the inner group consists of panels 7 and 8, and the outboard group consist of panels 9 to 12. In flight, the flight spoiler panels are opened when the speed brake lever is operated. This mode of operation is used to reduce airspeed in flight. After the aircraft lands, all the spoiler panels are also deployed as lift-dump devices.

FINAL REPORT

Panels 8 to 12 are designated as flight spoilers (and the corresponding panels 1 to 5 on the left wing) and they also deploy differentially in conjunction with aircraft roll commands. The innermost panel, No 7 (and the corresponding No 6 on the left wing) are not connected to the roll control system and are designated as ground spoilers.

1.7 Meteorological Information

1.7.1 There was broken to overcast cloud in the Dublin Airport area with a cloud base of 1500 ft. Visibility was greater than 10 miles. Wind was easterly at 10 kts. At take-off, the Commander estimated the weather to be scattered to broken at 1200 ft and visibility to be 10 miles and the wind to be easterly at 10 kts. Immediately prior to take-off, the flight crew observed a weather cell south of the departure runway.

1.8 Aids to Navigation

Dublin Airport is a fully equipped international airport. However, at the time of this occurrence the ILS to Runway 28 was inoperative, due to maintenance operations.

1.9 Communications

Not a factor in this investigation

1.10 Aerodrome Information

The main runway at Dublin is 28/10, which is 2,637 metres long.

1.11 Flight Recorders

1.11.1 Cockpit Voice Recorder

The aircraft was equipped with a Fairchild A100. This recorder records the last 30 minutes of information. As the recorder was left on for some time after landing, the data relating to the pertinent section of the flight was taped-over and the relevant data was lost.

1.11.2 Flight Data Recorder

The aircraft was equipped with a Fairchild Flight Data Recorder (FDR). The FDR uses the same sensing air units as the pilots' instruments for recording airspeed and altitude information. Therefore the information recorded on the FDR was identical to that displayed on the pilots' instruments. Knowing the configuration of the aircraft and other data such as altitude and weight, the aircraft manufacturer estimated that when the aircraft was at the maximum displayed airspeed, 270 kts, the true airspeed was in fact 335 kts, giving an under-reading of 65 kts.

FINAL REPORT

1.12 **Wreckage and Impact Information**

Not Applicable.

1.13 **Medical Information**

Not Applicable.

1.14 **Fire**

There was no fire.

1.15 **Survival Aspects**

Not Applicable.

1.16 **Tests and Research**

Post flight inspection of the aircraft showed that the A&E Bay drains in both static pressure sensor lines were open, i.e. the normal blanking caps were not fitted.

Further investigation found that the standard airspeed calibration and leak checks had been conducted with the static lines of the test rig connected to the aircraft static system at the A&E Bay drains (i.e. the second method as noted in para 1.6.2.3 above).

1.17 **Organisational and Management Information**

Not Applicable.

1.18 **Additional Information**

1.18.1 **Recent Maintenance**

Following the discovery that the blanking caps on the static drains in the A&E Bay were missing after the test flight, all the staff involved in the appropriate areas were interviewed by the Investigation in order to determine the sequence of events.

An outline of the relevant events is as follows:

An avionic crew were performing pitot-static leak checks up to and including Friday 5 May 2000. The methodology being used was to attach the static test line of the test rig to the A&E Bay drains (i.e. the second procedure noted in 1.6.2.3 above). The static test line from the rig was blue in colour. It was connected via an inline connection to a clear plastic line. The other end of the clear plastic line was connected to a tee connector, which was in turn connected to two adaptors that were connected onto each of the static drain ports.

FINAL REPORT

During the tests, the system was satisfactory from the aspect of leaks, but it was noted that the Captain's IVSI was lagging, and required replacement. No replacement unit was available so one was ordered AOG (Aircraft-on-Ground - which is a priority ordering system).

The checks were completed on Friday 5 May, with the exception of the IVSI replacement. The avionic crew manager decided to leave the test equipment attached to the aircraft, in order to complete the tests when the replacement IVSI was fitted. He also stated that he had recently transferred from Line Maintenance to Aircraft Overhaul. He had not been working on N520UP for the full duration of the check and he had also been working on another aircraft check in No.3 hangar, while the check on N520UP was in progress. He stated that he was present for the full pitot-static system test. He also stated that when he was going home at 3 p.m. on Saturday 6 May, he was not aware that the aircraft was going to be weighed later that day. The work card for the pitot-static check was signed off on Sunday 7 May.

The avionic crew manager stated that he signed off the work card, having raised an NRC (A Non Recurring Card – a job card calling up one specific non-recurring task) for the IVSI replacement, but omitted to include a call up for further leak and calibration checks of the Captain's and First Officer's system. It was his intention to do the full checks following the IVSI replacement and for that reason the pitot-static test- rig lines were left connected to the aircraft.

A second avionic crew manager was involved in the ongoing pitot-static leak checking of No. 1 and No.2 aux pitot-static system. He took responsibility for certifying the installation of the Captain's IVSI. He stated that he had instructed an avionic apprentice to connect the leak test rig into the drains, as this was an acceptable method in accordance with the aircraft operator's Maintenance Manual used during this check. In relation to the installation and testing of the Captain's IVSI, he stated that as the new unit had a self-sealing quick-disconnect coupling, it did not require a system pitot-static calibration or leak test. The IVSI was eventually fitted to the aircraft on Tuesday 9 May, as there were delays in obtaining a serviceable unit.

At 15.00 hours on Saturday 6 May, on completion of their shift, all the avionic personnel went home, leaving the leak test rig connected to the aircraft. It appears that none of these personnel were aware that the aircraft was to be weighed later that day.

The acting airframe/engine shift manager stated that he was in charge of weighing the aircraft and that he had organised a crew to assist him. This operation commenced on 6 May at 15.00 hours. In order to prepare the aircraft for weighing, he gave instructions to a mechanic to disconnect the test equipment from the pitot probes. In relation to the static pipes he personally disconnected the coloured lines from the test equipment at the quick disconnect fittings and left them lying on the floor. He was not aware of what subsequently happened to them.

FINAL REPORT

He stated that there was no meeting or handover between himself and the earlier avionic crew and he agreed that if a meeting had taken place that this incident would probably not have occurred. He also stated that during the week there is a daily progress meeting for crew management from the different areas of the aircraft and that everyone was aware that the aircraft was scheduled for weighing at 18.00 hrs on Saturday 6 May. Such meetings do not take place at the weekends.

He stated that the aircraft weighing was completed at 21.30 hrs and then he went home.

An airframe/engine crew manager stated that he rolled up the clear static tubing and put it in the A&E Bay sometime between 17:15 and 18:00 hrs. He also stated that the blue tubing was not connected to the clear tubing at that time.

An airframe mechanic observed that the tubes were still hanging down the A&E Bay door at 18.00 hrs and he heard an instruction to disconnect the hoses in this area. Another airframe mechanic recalled hearing a request from somebody inside the A&E Bay for an 11/16" spanner. Shortly afterwards the tubes came down to floor level. 11/16" is the spanner size of the adaptor that was screwed into the drain fittings. This adaptor is used to connect the clear plastic lines, from the test-rig lines, to the drains.

Efforts by the Investigation and the company to identify the person in the A&E bay were not successful, in spite of assurances that no blame would be apportioned to this person.

On the following Tuesday, 9 May, the replacement IVSI was fitted. The leak checks were not repeated. This was because that replacement unit was fitted with quick-release connections, and it is not a requirement that the system be checked for leaks following the installation of an instrument with this type of connection.

1.18.2 Post Occurrence Inspection

Subsequent to this occurrence, the aircraft was inspected for possible damage arising from the aircraft being flown at high speed with the undercarriage lowered and the flaps deployed. No additional damage, beyond that noted in para 1.3 above, was found.

1.18.3 Maintenance Manuals

During the Investigation it was found that an out-of-date UPS AMM was in use in the maintenance facility at the time. The aircraft operator's Technical Library system operates by issuing the maintenance provider's organisation with a number of Technical Data accounts as per the aircraft operator's General Maintenance Manual requirements. These accounts require an inventory check to be carried out at intervals of 30 days maximum by a dedicated person. The aircraft operator's Technical Library system differs from the maintenance provider's Technical Library Operating System. At a meeting in Hangar 5 of the maintenance providers, in June 1999, it was agreed that the aircraft operator's (UPS) Technical Library operating system (accounts) would be used for checks on the aircraft operator's aircraft.

FINAL REPORT

Present at this meeting were the maintenance provider's Quality Assurance Manager, the aircraft operator's Quality Assurance local representatives, the maintenance provider's Contract Manager Hangar 5, and Maintenance Technical Library staff.

The inventory check by the maintenance provider failed to accomplish the removal of superseded AMM Reference UPS 52081. It was this manual which authorised the second procedure (see 1.6.2.3 above) for leak testing of the pitot-static system.

1.18.4 Reporting Of Occurrence

Neither the aircraft operator's flight crew, nor the aircraft operator's organisation, reported this occurrence to the AAIU, as required by Irish legislation {Statutory Instrument SI 205 of 1997, Air Navigation (Notification and Investigation of Accidents and Incidents) Regulations}. First knowledge of the occurrence came from Dublin ATC. At this point the seriousness of the occurrence was not appreciated. The aircraft operator's company instigated its own investigation, which involved removal of the CVR and FDR. The aircrew also left Ireland the following day. As the occurrence took place on a Friday, and due to the lack of detail in the original report, the AAIU investigation did not commence until Monday 15 May. This delay did cause some difficulties in the initial phase of the investigation, and in addition resulted in the investigation not having an opportunity to interview the flight crew immediately after the occurrence.

The maintenance provider did report the occurrence to the Irish Aviation Authority (IAA), as required by IAA regulations and JAR 145

1.18.5 Follow-up Action

1.18.5.1 When the full implications of this occurrence were ascertained, the IAA, as the aviation safety regulatory authority in Ireland, conducted an investigation of this occurrence from a regulatory aspect. Pursuant to this investigation, the IAA took regulatory action. In the course of a previous IAA investigation, staff members of the maintenance provider were formally cautioned. The IAA informed this Investigation that they consider this to be only occasionally necessary, where a prosecution might ensue.

1.18.5.2 The No. 8 spoiler actuator was changed after this occurrence. This cured the vibration problem.

1.18.6 Commander's Statement

Some time after the occurrence the Commander returned to Ireland and was interviewed by the Investigation. In the course of this interview he made the following comments:

- With after-knowledge, the vibration on take-off was caused by excess true airspeed.

FINAL REPORT

Normally he would have realised this, but the experience of the spoiler vibration on the ground tests gave him a false lead, and lead him to initially deduce that the vibration was a recurrence of the spoiler problem.

- The wind-shear warnings were an additional distraction during the take-off phase.
- The company check-list, which was used on this flight, does not list a drill for static failure. There is a section in the aircraft manuals dealing with unreliable static information, but it was not realistic to access these manuals during this emergency.
- The primary clue that there was a problem in the static system was when the altimeter changed from radio altimeter to barometric mode, and the indication remained steady. This was despite the fact that the airspeed was increasing and the attitude indicators indicated a nose-down (descending) attitude.
- His crew performed very well.
- The assistance given by Dublin ATC was excellent.
- They were fortunate that the occurrence took place in relatively benign weather conditions. If the flight had been performed at night and/or IMC condition, the outcome may have been less successful.
- Due to the static system design in this aircraft, going to the alternative (alt) static source would not have cured the problem, and thus the alt source was not selected during this flight.
- With the benefit of hindsight, he believed that they would have got better static information if they had turned off the pressurisation packs, opened the pressurisation outflow valve and thereby depressurised the aircraft.

1.18.7 Aircraft Operator's Procedures

At the time of this occurrence, the aircraft operator's procedures for post-maintenance check flights lays down that such flights should be conducted in conditions not below VFR minima's and must be conducted in daylight.

1.18.8 Aircraft Operator's Revised Procedure

Subsequent to this occurrence the aircraft operator revised their procedures for Conditional Test Flights. The revision now includes a procedure to pressurise the aircraft prior to take-off, and to ensure that this does not cause the Altimeter, ASI or VSI to move. This procedure checks that the static system is not reading the internal air pressure in the fuselage and thereby ensures that the static drains are sealed.

FINAL REPORT

1.18.9 Maintenance Provider's Initiatives

At the time of this occurrence, the maintenance provider's organisation has prepared a draft Maintenance Safety Management Plan, in accordance with IAA Aeronautical Notice A.67. This plan has not yet been approved and adopted by the maintenance provider's organisation. However the company has informed this Investigation that all the material elements of a Maintenance Safety Management System are in place.

1.18.10 Boeing Response

In a response to the draft report on this occurrence, the Boeing Company stated that the Boeing B747 Operations Manual Vol. II page 14.20.01 "Flight with Unreliable Airspeed/Mach Indications" and a performance table on page 23.20.21 is provided specifically for this situation and should have been readily accessible to the crew.

The Boeing Company response went on to state:

"The procedure provides the data necessary to maintain reasonable airplane speed and airplane control by using pitch and power settings. Even though the crew safely landed this airplane, use of these procedures would have reduced the approach and landing speed and stopping distance. This would have reduced the risks and increased the safety margins for the landing. In addition, the performance table, page 23.20.21, gives pitch and power settings as a function of gross weight. Boeing believes that using this pitch and power procedure would have made flying the airplane easier, even at the extremely light weight of the airplane."

Boeing also pointed out that an article in the October 1999 issue of the Boeing Aero Magazine dealt with this issue.

1.18.11 UPS Response

In a response to the draft report on this occurrence, the UPS requested that the following be added to the report:

"An additional option that should be addressed is the inclusion of an Angle of Attack (AOA) presentation in the cockpit."

The AOA provides immediate reference for stall protection in the event that there is a failure of both airspeed indicators. The information presented by the AOA is immediate and continuous as opposed to the task of referencing charts in manuals. It is also more accurate than using Target Pitch and Thrust Settings.

Additionally, in cases where the Captain's and the First Officer's airspeed indicators do not agree, the AOA would provide a reference source to the flight crew to help determine which airspeed indicator is reading correctly."

FINAL REPORT

2. ANALYSIS

2.1 **The Flight**

- 2.1.1 Due to the fact that the blanking caps were missing on both drains, the internal hull pressure was fed into the static system on both the Captain's and F/O's instruments. As the aircraft took off, the air pressure within the hull was slightly higher than the pressure measured by the static ports. This caused the airspeed indicators to under-read. As the pressurisation system came on-line, thereby further increasing the air pressure within the hull, the airspeed indicator under-read to a more significant degree. The IVSI and altimeters were also under-reading. As the altitude information supplied to the aircraft's radar transponder was also supplied by the same static source, the altitude information displayed in the ATC radar screens was subject to the same error.
- 2.1.2 The standard check by the pilots, i.e. comparing both airspeed indicators at 80 kts, failed to detect any anomaly because both instruments were under-reading by a similar amount. The usefulness of this check is that it will detect if one system is faulty. It will not reveal that both systems have a common fault.
- 2.1.3 As the aircraft climbed the airspeed indicators continued to under-read by an increasing amount, due to the increasing differential between the cabin pressure and the external ambient air pressure.
- 2.1.4 After take-off the aircraft failed to achieve its normal rate of climb. This was because the aircraft was actually flying considerably faster than the indicated airspeed, and the extended flaps were creating much more drag than usual due to the excessive true airspeed. At the same time the indicated airspeed was much less than the true airspeed, due to the open static drains.
- 2.1.5 The extended flaps induced airframe vibration due to the excessive airspeed. The crew initially believed that this vibration was caused by the spoiler problem identified before take-off.
- 2.1.6 The wind shear warnings caused by the sudden loss of indicated airspeed. This system is triggered by a rapid change of indicated airspeed, which in this case was caused by the pressurisation packs coming on-line, thereby pressurising the static system through the open static drains, and resulting in a rapid reduction of indicated airspeed.
- 2.1.7 Selection of ALT static port would not have corrected the problem, because the higher-pressure air from the cabin pressurisation would have entered the static system between the ALT static selector valve and the crew's instruments.

2.2 **Maintenance Events**

- 2.2.1 There was an ineffective handover between the work-shifts at 15.00 hrs on Saturday, 6 May. This resulted in the later crew, who conducted the weighing, being un-aware that the checking of the pitot-static system was not complete. The lack of organised hand-over meetings at weekends was a major factor in this ineffective handover.

FINAL REPORT

- 2.2.2** The fact that the work card for completing the leak test was signed off, allied with the mistaken belief of the avionic crew manager that a further leak test would be required after the replacement of the IVSI, resulted in no outstanding call-up being made for the completion of leak tests after 5 May.
- 2.2.3** The fact that leak checks were not required following the fitting of the IVSI, due to the self sealing fittings on the IVSI, was unknown by the avionic crew manager who certified the initial check. Thus a safety resource that he believed to be in the system was in fact, absent.
- 2.2.4** This avionic crew manager had recently transferred from line to overhaul maintenance. He was also involved in maintenance on another aircraft. His appreciation, experience and comprehension of the need for the ongoing interaction of the various teams involved in overhaul maintenance may have been less than optimum.
- 2.2.5** The use of superseded UPS AMM manuals resulted in the use of a procedure that is not recognised in the current edition of the AMM. If the current UPS AMM had been used, the drain connections would not have been used for the leak tests, thereby preventing this serious incident. However it should be noted that both maintenance procedures are still approved in the AMM supplied by the aircraft manufacturer.
- 2.2.6** The failure to find the person who disconnected the test rig lines from the drains is a matter of concern. This is discussed further in section 2.3 below.
- 2.2.7** The presence of vibration in the spoiler control system, as noted by the flight crew before take-off, hindered the flight crew's initial analysis of the vibrations experienced in flight. Thus the onset of airframe vibrations, which was due to excessive true airspeed with the flaps extended, was initially believed to be related to vibration in the spoiler system that was detected on the ground.
- 2.2.8** The aircraft operator's flight crew had an obligation to report this occurrence to the AAIU, it being the appropriate authority in the State of Occurrence, but did not do so. The operator's action of removing the aircraft recorders from the local jurisdiction could have compromised the subsequent investigation.
- 2.2.9** While it was not the responsibility of the maintenance provider to notify the AAIU of this occurrence, there is always the possibility that foreign aircraft operators, having their aircraft undergo maintenance in Ireland, would be unaware of the local regulations regarding the reporting of occurrences, as indeed occurred in this case. The Investigation therefore considers that it would be good practise for maintenance providers to inform the AAIU of such occurrences involving foreign registered aircraft. It is noted that the maintenance provider did comply with the regulatory requirement to inform the IAA.

2.3 The Investigations

- 2.3.1** This occurrence was investigated by both by the AAIU as the National body responsible for the investigation of aviation accidents and serious incidents, and by the IAA, as the regulatory body for aviation safety.

FINAL REPORT

2.3.2 There may be some confusion among personnel in the aviation industry regarding the differences between investigations conducted by the AAIU and the IAA. Prior to 1994 one body, the then-Department of Transport, Energy and Communications, performed both the Regulatory function and the Annex 13 Investigation function. In 1994 the AAIU and IAA were formally set up as two separate and independent organisations. The role of the AAIU is to investigate accidents and incidents with the object of making safety recommendations, in order to prevent a re-occurrence of similar events in the future. The AAIU is specifically precluded from apportioning blame or liability. The IAA, as the aviation safety regulatory authority, is responsible, among other functions, for the enforcement of aviation regulations in Ireland, and this includes the authority to prosecute organisations and individuals. As part of the process of taking a successful prosecution, the IAA must formally caution an individual before taking a statement, if there is a possibility that the IAA may subsequently use such a statement in the prosecution of that individual. This division of roles and responsibilities may not have been fully understood by staff of the maintenance provider's organisation. It is therefore possible that the staff experience of being formally cautioned during the course of an IAA investigation may have had a detrimental effect on the willingness of staff to assist the AAIU investigation of this occurrence.

2.3.3 Subsequent to the circulation of the Draft AAIU Report of this occurrence, the IAA proposes to issue an Aeronautical Information Circular (AIC) to clarify this matter. The AAIU agrees with this course of action.

2.4 Other Matters

2.4.1 The aircraft operator's procedure of performing post maintenance test flights in conditions above VFR minima's and only in daylight was a significant factor in the successful outcome of this occurrence. The aircraft did enter cloud for a period shortly after take-off, and this was a particularly difficult phase for the crew. The crew stated that finding a suitable break in the clouds for the initial descent was also a significant factor to the successful recovery of the aircraft. This suggests that it would be prudent that such flights be conducted in daylight VMC conditions, without entering cloud, or at least in weather conditions would allow that the initial stages of the flight are conducted in VMC conditions. This would allow the crew to check that all flight instrumentation and flight control systems are operating satisfactorily before the aircraft enters IMC conditions.

2.4.2 The revised procedure introduced by the aircraft operator (ref para 1.18.8 above) should ensure that they do not suffer a similar occurrence for the same reason, in future.

2.4.3 The aircraft was operated on this flight at a very light take-off weight for this aircraft type. The weight configuration was unusual, compared to normal revenue operations and consequently the relationship between aircraft pitch, power and actual airspeed was not within the parameters encountered during routine operation of the aircraft. Thus it may have been more difficult for the crew to adapt to flying the aircraft, using just pitch and power settings, without reliable airspeed information.

FINAL REPORT

- 2.4.4** The performance of the flight crew in this occurrence was excellent, given a potentially disastrous situation. There is little doubt that the professional conduct of the crew, and their very considerable experience, were major factors in the successful outcome of this occurrence. The assistance rendered by Dublin ATC also contributed to a safe outcome.
- 2.4.5** The maintenance provider has prepared a draft Maintenance Safety Management Plan. This Investigation believes that it is appropriate that this plan be implemented.
- 2.4.6** In some of the responses to the Draft Report of this Investigation, it has been argued that the crew could have made greater use of the data available maintaining reasonable aircraft speed by using pitch and power settings and/or the use of the AOA presentation. The Investigation accepts that this was possible. However the Investigation also believes that it was appropriate for the crew to concentrate on the fundamentals, i.e. to continue to fly the aircraft, maintain their situational awareness, keep the aircraft clear of cloud, regain ground/sea visual contact and land the aircraft as soon as possible. It is possible that in the situation of this particular flight, in the circumstances that prevailed, at relatively low altitude and without a clear understanding of the cause and extent of the problem with the aircraft, that an attempt to calculate the airspeed from available parameters may have unduly distracted the crew and resulted in a less satisfactory outcome.

3. CONCLUSIONS

3.1 Findings

- 3.1.1** The damage to the aircraft resulted from the aircraft inadvertently being flown at an excessive speed with the flaps lowered.
- 3.1.2** The reason for the excessive true airspeed was a significant under-reading of both airspeed indicators.
- 3.1.3** The airspeed indicators under-read due to pressurised air from inside the aircraft feeding into both pilots' static system through the static drains in the A&E Bay. The sealing caps on these drains had not been refitted after maintenance. This fault also resulted in false altitude indications, false wind-shear alerts, false vertical speed indications and false transponder altitude output.
- 3.1.4** A maintenance procedure was performed on this aircraft that was no longer approved by the aircraft operator for use on their version of the B747. This superseded procedure permitted the use of the static drains for leak testing of the static system.
- 3.1.5** The aircraft operator's approved method for performing leak tests, at the time of this maintenance, did not authorise use of the static drains for this purpose.
- 3.1.6** The use of superseded maintenance manuals resulted in the use of a maintenance procedure that was no longer approved by the aircraft operator. However, the aircraft manufacturer approves this procedure and therefore it meets the approval criteria for JAR 145.

FINAL REPORT

- 3.1.7** An unstructured system of shift handover at weekends resulted in a poor exchange of information with the off-going and incoming shifts.
- 3.1.8** The failure of some personnel within the maintenance provider organisation to come forward, following maintenance procedures errors is a matter of concern. The Investigation considers that confusion among some staff regarding the functions and activities of the IAA and the AAIU may have influenced staff in this matter.
- 3.1.9** The difficulties experienced by some personnel who were transferred from line maintenance appointments to a heavy check environment, suggests need for reappraisal of aspects of personnel training within this organisation.
- 3.1.10** The aircraft operator failed to report this occurrence to the appropriate local authorities as required by Statutory Instrument SI 205 of 1997, Air Navigation (Notification and Investigation of Accidents and Incidents) Regulations, 1997, and removed the flight recorders from the aircraft and from the jurisdiction, without authorisation.
- 3.1.11** The successful recovery of the aircraft was in part due the fact that the flight did not take-off in IFR conditions or at night. The wisdom of aircraft operator's procedure of conducting such post-maintenance check flights only in daylight was clearly demonstrated in this case. However, the fact that the aircraft did subsequently enter cloud, and operated above cloud, did increase the difficulties faced by the flight crew.
- 3.1.12** The experience and professionalism of the aircrew were the primary factors in the safe recovery of the aircraft.

3.2 Causes

- 3.2.1** This incident was caused by the failure to replace the static drain blanking caps following maintenance.
- 3.2.2** A contributory cause was a poor hand-over procedure between work shifts.

4. SAFETY RECOMMENDATIONS

- 4.1** The maintenance organisation should review their procedures for shift handover, especially at weekends. **(SR 8 of 2004)**
- 4.2** The maintenance organisation should review their training programmes for personnel transferring from line maintenance appointments. **(SR 9 of 2004)**
- 4.3** The maintenance organisation should review their procedures that ensure that only current versions of maintenance manuals are in use. **(SR 10 of 2004)**

FINAL REPORT

- 4.4 The maintenance organisation should ensure that their staff are aware of the difference of function between the IAA and the AAIU, and the different objectives of investigations conducted by both organisations. **(SR 11 of 2004)**
- 4.5 The aircraft operator should review their procedures for post-maintenance test flights, in relation to weather minima's, particularly in relation to cloud base and cloud cover, in order to ensure that an aircraft does not enter IMC conditions in the early phase of a post-maintenance test flight. **(SR 12 of 2004)**
- 4.6 The aircraft operator should revise their procedures to ensure that their flight crews comply with Irish regulations relating to the reporting of an accident or serious incident. Such action may also be appropriate for other jurisdictions. **(SR 13 of 2004)**
- 4.7 The maintenance provider should continue with the implementation of their draft Maintenance Safety Management Plan. In this plan, consideration should be given to including an explanation of the respective roles of the IAA and the AAIU with respect to the investigation of occurrences. **(SR 14 of 2004)**
- 4.8 The IAA should consider an AIC to fully explain the air safety roles of the AAIU and the IAA in respect of air accident investigation. **(SR 15 of 2004)**

FINAL REPORT

Appendix A

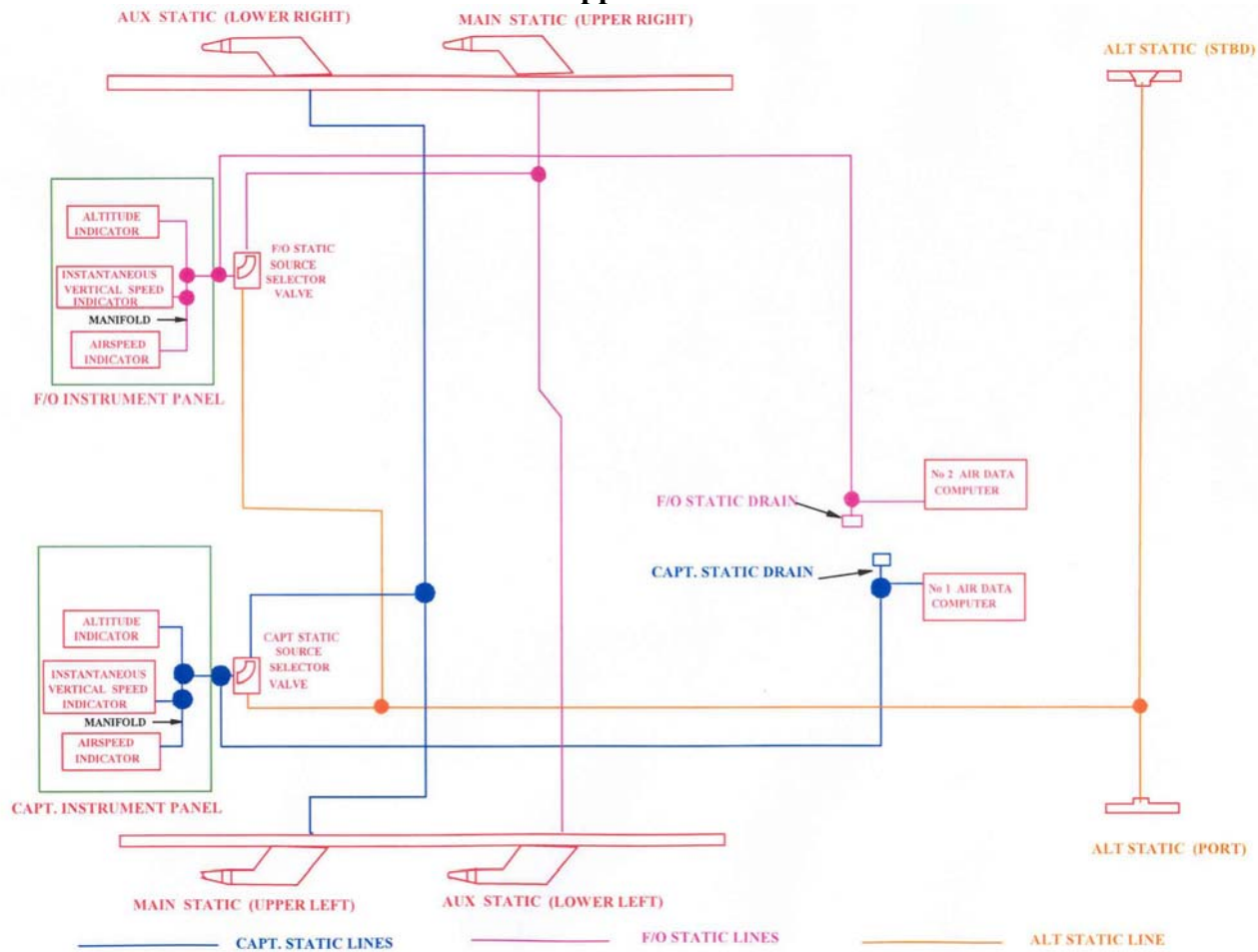

Flight Instrument Static System Simplified Schematic`

This schematic shows only the static system that is connected to the flight instruments